

Memorandum for Resource Managers and Water Control Manual holders

Subject: Modification of Huntington District Water Control Reporting Procedures.

1. Reference CELRH-EC-WM Memorandum to Kent Browning, dated 20 January 2004, Subject: Modification of Huntington District Water Control Reporting Procedures.

2. The referenced memorandum modifies certain reporting procedures. Since that memorandum was issued, improvements in technology have resulted in the National Weather Service providing detailed snow analyses data in graphical maps via the internet. This data satisfies Water Managements needs, and therefore an additional modification is necessary.

3. Modify Instructions to Dam Tender, Section 2 – Precipitation at Project, sub-section: Snow Depth and Moisture Content:

Replace the section in its entirety with the following:

"Report snow data to Water Management only when directed to do so. Measure and record the water content of the snow at least as often as indicated below.

- (1) Each day when rain falls on existing snow cover
- (2) Twice a week on Mondays and Thursdays when there is snow cover on the ground if condition (1) does not require more frequent measurement.

4. This change in reporting instructions does not modify the Project's requirement to store this data on site.

5. This memorandum shall be placed in the front of the Water Control Manual to document the change.



Timothy W. Curran, P.E.
Chief, Water Management Section

Memorandum for Resource Managers and Water Control Manual holders

Subject: Modification of Huntington District Water Control Reporting Procedures.

1. Reference CELRH-EC-WM Memorandum to Kent Browning, dated 20 January 2004, Subject: Modification of Huntington District Water Control Reporting Procedures.
2. The referenced memorandum modifies certain reporting procedures, and this memorandum makes an additional change. Some Water Control Manuals have been revised with the new procedures the "Instructions to Resource Manager" or "Instructions to Dam Tender" section. Manuals that have not been revised should have the referenced memorandum placed in the front of the manual. Make handwritten changes to the memorandum or the Water Control Manual, as appropriate. This memorandum shall be placed in the front of the Water Control Manual to document the change.
3. Modify Instructions to Dam Tender, Section 4 – Regular Reports, sub-section: Weekly Precipitation Report, second and third sentences:

Replace the text "This report must be filled out and transmitted every Monday morning by 0800 hours. If Monday is a holiday, it shall be filled out on the next work day by 0800 hrs." with "This report is no longer required to be completed on a weekly basis. It shall only be filled out and submitted if required by special directive."



Timothy W. Curran, P.E.
Chief, Water Management Section

CELRH-EC-WM

20 January 2004
Schray/5604

3/16/04
elle

Memorandum for Kent Browning, OR Water Management POC.

Subject: Modification of Huntington District Water Control Reporting Procedures.

1. Please distribute this memorandum to all Huntington District Flood Control Project Managers, direct them to place this memorandum in the front of the Water Control Manual, and make notes in the text which has been superseded.
2. As directed by the QC, EC-WM is implementing the recommendations of the Reservoir Reporting Process Action Team. As such, the following changes shall be made to the water control manuals and the associated processes:

The following sections are modified as noted.

Instructions to Dam Tender, Section 2 - Precipitation at Project, sub-section: Snow Depth and Moisture Content

Measure and report to EC-WM by 0900 hours the water content of the snow at least as often as indicated below.

- (1) Each day when rain falls on existing snow cover
- (2) Twice a week, on Mondays and Thursdays, when there is snow cover on the ground if condition (1) does not require more frequent measurements.

Instructions to Dam Tender, Section 2 - Precipitation at Ohio River Network Stations

Reports to the National Weather Service are carried out by agreement between the Project and the Weather Service and at their direction. The project is not required to gather or submit any additional data to Water Management beyond what is described previously in section 2 and what is detailed in section 4.

Sub-Sections a, b, and c are therefore no longer relevant except as to describe how to gather and provide data to the National Weather Service.

Instructions to Dam Tender, Section 4 - Regular Reports, sub-section: Weekly Report, ORH 14

This section is rescinded in its entirety and is replaced by sub-section: Historical Files.

Projects are required to maintain a permanent hard copy at the project of all water control data required for daily operation. This data shall be comprised of the information the project has historically gathered using the ORH 14 and 13 reports and shall be gathered at 0730 on days when the project is staffed, at other times as directed by the Schedule for Reading Gages and the Project Manager and when data is requested by Water Management Section. It shall include but not be limited to: Precipitation, Current Weather conditions, Lake Stage Levels, Outflow Stage Levels, Gate Settings, Gate Operations and time performed, Snowfall, Snow on the Ground, Total Moisture Content as directed in Section 2, and all Upstream and Downstream gauge readings which are utilized by project personnel for gate operation decision making.

This information may be maintained either on the historical reports or a new project developed format.

Instructions to Dam Tender, Section 4 - Regular Reports,
sub-section: Daily Morning Report

This sub-section is modified to note that: Generation and transmission of the daily morning report (also call the intranet report which replaced the ORH-13 Daily report) is only required when requested by the Water Management Section. Automatic daily transmissions are no longer necessary.

Note: Atwood, Bolivar, Clendening, Piedmont, Tappan, and Tom Jenkins are still required to report all gate operations to EC-WM by phone. Extra emphasis will be placed on these phone calls as Water Management will no longer be able to look up the previous day's gate operations every morning.

Instructions to Dam Tender, Section 4 - Regular Reports,
sub-section: Gate Operations Report

This sub-section is modified to note that: Generation and transmission of the gate operations report is only required when requested by the Water Management Section. Neither daily transmissions nor transmissions after every gate operation are necessary any longer.

Instructions to Dam Tender, Section 4 - Regular Reports,
sub-section: Weekly Precipitation Report

This sub-section shall be added after the Water Quality Report sub-section.

A fourth report available from the Index Page is the Weekly Precipitation Report. This report must be filled out and transmitted every Monday morning by 0800 hours. If Monday is a holiday, it shall be filled out on the next work day by

0800 hours.

Upon accessing the Weekly Precip Report link on the Index Page, fill in the daily precipitation for the past week. When all data for the week is filled in, save the spread sheet and exit. This record will be saved for the entire year and can be viewed through the link used to modify it.

On days when the project is not staffed, place a "NS" in that day's field and report the combined day's precipitation in the next day when the project is staffed. I.e. If the project does not staff the weekend, place a "NS" in the field for Saturday and Sunday and report the 72 hour precipitation record on Monday morning.

Instructions to Dam Tender, Section 4 - Regular Reports,
sub-section: Additional Comments

This sub-section shall be added after the Weekly Precipitation Report sub-section.

A fifth link available on the Index Page is the Additional Comments link. It shall be used when ever the Project has special information or questions that it wants to bring to the immediate attention of the Water Management team. Snow Moisture shall be reported using this link.

Upon accessing the Additional Comments link on the Index page, a blank email to the Water Management Team will be generated. Please note in the subject line, the nature of the issue and then provide supplemental data in the text block of the message. After the email has been completed click on the submit/send button to send the message.

Instructions to Dam Tender, Schedule for Reading Gages

The last sentence of the top paragraph "Stream gages and the precipitation gage (all gages) shall be read at least as often as shown in the table below", shall be replaced with: "Reading and recording of gages shall be carried out as defined under Schedule A except when gage levels/precipitation are such that the Resource Manager or their Acting anticipates that problems may result, at which point the relevant schedule B, C, or D shall be followed for reading and recording of all required gages. Transmission of project gage data will be at the request of EC-WM.

Modify the chart as follows:

SL, SO, and DCO shall be read in all schedules monthly as a check

Modify the footnotes as follows:

(1) When any one of the conditions listed under schedule A, B, C is exceeded and problems are anticipated, place the next higher schedule into effect. When conditions are such that would place schedules C or D into effect, notify by phone one of the Water Control personnel.

Timothy W. Curran, P.E.
Chief, Water Management Section

CF:EC-WH



DEPARTMENT OF THE ARMY
HUNTINGTON DISTRICT, CORPS OF ENGINEERS
502 EIGHTH STREET
HUNTINGTON, WEST VIRGINIA 25701-2070

REPLY TO
ATTENTION OF:

CELRH-EC-W(11110-2-1403a)

12 September 2003

MEMORANDUM FOR COMMANDER, Great Lakes and Ohio River Division,
ATTN: CELRD-ET-W

SUBJECT: Water Control Manual for Clendening Lake

1. Forwarded herewith are two copies of the subject manual for your retention. There are no changes to the water control plan operating procedure. Changes include changing from the 11 chapter format to the 9 chapter format according to ER1110-2-8156 and the addition of water quality information.
2. If you have any questions, please contact Mr. Charles Brown at [REDACTED]

2 Encls

John J. Jaeger, Ph.D., P.E.
Chief, Engineering & Construction Division

U.S. ARMY ENGINEER DISTRICT, HUNTINGTON
CORPS OF ENGINEERS
HUNTINGTON, WEST VIRGINIA

CLENDENING LAKE
STILLWATER CREEK BASIN
OHIO

PROJECT MANUAL
FOR WATER CONTROL MANAGEMENT
CLENDENING LAKE - BRUSHY FORK
STILLWATER CREEK

PREPARED BY
CORPS OF ENGINEERS
HUNTINGTON DISTRICT
WATER RESOURCES ENGINEERING BRANCH

SEPTEMBER 2003

CORPS OF ENGINEERS

U. S. ARMY

CLENDENING F/C 7



CLENDENING F/C 7-A

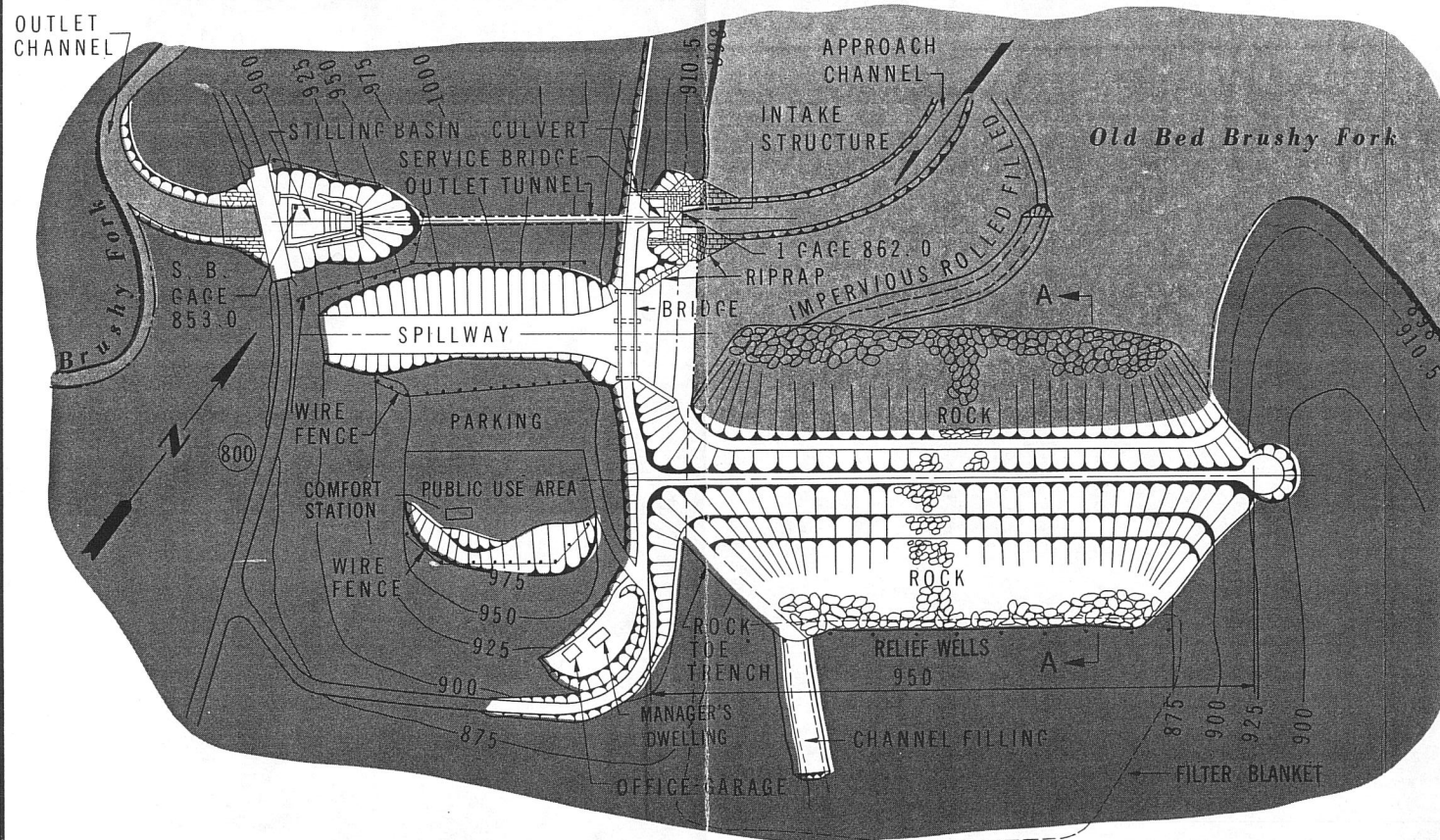
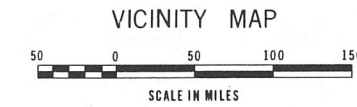

PLAN

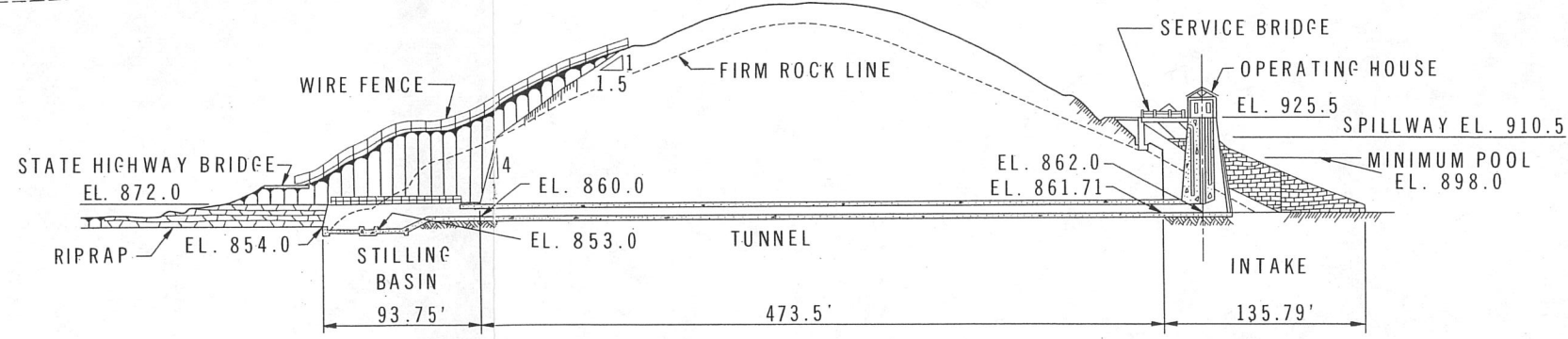
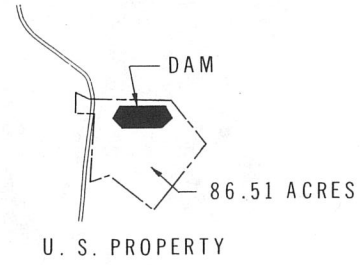
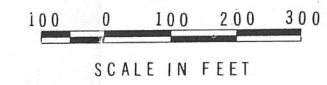

PROFILE ON CENTER LINE OF OUTLET WORKS

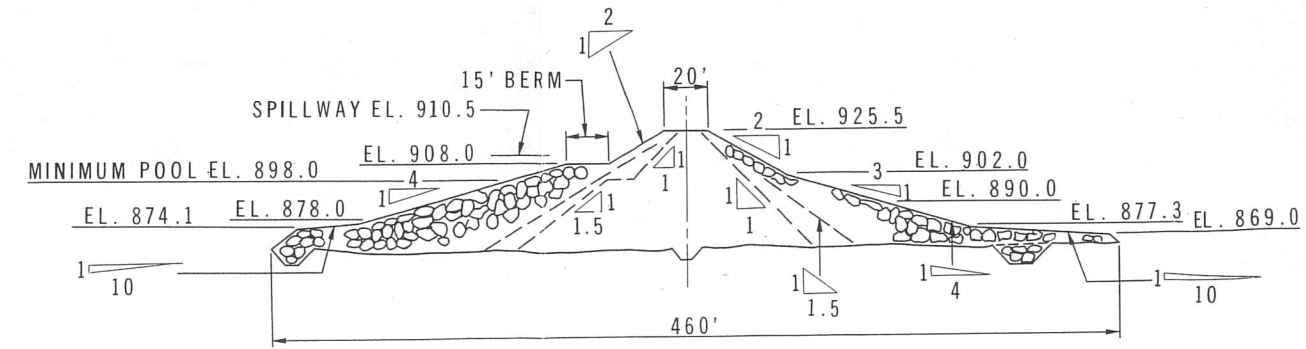
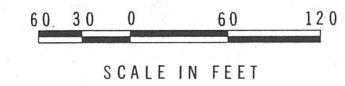

SECTION A - A



**MUSKINGUM RIVER
CLENDENING LAKE
DAM AND SPILLWAY
PLAN, PROFILE AND SECTION
HUNTINGTON DISTRICT, HUNTINGTON, W. VA.
Revised : 30 SEPTEMBER 1984**

PHOTOGRAPH

NOTICE TO USERS OF THIS MANUAL

Regulations require that this Water Control Manual be published in a hard backed 3-ring binder with the text in loose leaf form. In this way, only those sections or parts thereof requiring changes need be revised and printed. Therefore, this copy should be preserved in good condition in order that single page inserts can be made to keep the manual current. Changes to individual pages must carry the date of revision, which is the Great Lakes and Ohio River Divisions' approval date.

REGULATION ASSISTANCE PROCEDURES

In the event that unusual conditions arise during non-duty hours, communications can be achieved by contacting, in the order listed, one of the following. Plus all numbers are found at:

[REDACTED]

CORPS OF ENGINEERS
Muskingum Area Office,
Dover, Ohio

[REDACTED] Area Manager

Normal Work Hours,..... [REDACTED]
Night, weekend, Holiday, NWS observers
Home
Nicholas E. Krupa..... [REDACTED]

KEY EMERGENCY CONTACTS

Huntington District Office, Water Resources Engineering Branch
Normal Work Hours, Nights,..... ([REDACTED])
Weekends, and Holidays..... [REDACTED]

<u>DISTRICT PERSONNEL</u>	<u>Office Assignment</u>	<u>Telephone</u>
<u>Water Resources Engineering Branch</u>		<u>Residence</u>

[REDACTED]		
Water Management Section	([REDACTED]

[REDACTED]		
Water Management Section		[REDACTED]

Pertinent telephone numbers that may be of value during a flood emergency are listed below:

Other Agencies

U. S. Geological Survey
New Philadelphia, Ohio..... [REDACTED]

Night, Weekend, Holidays
Lowell Trimble..... [REDACTED]

National Weather Service
W. S. Forecast Office..... [REDACTED]
Hydrology Section..... [REDACTED]
Cleveland, Ohio

US Army Corps of Engineers
Huntington District
2003

TABLE OF CONTENTS

TITLE PAGE.....	i
PHOTOGRAPH.....	ii
NOTICE TO USERS OF THIS MANUAL.....	iii
REGULATIONS ASSISTANCE PROCEDURES.....	iv
PERTINENT DATA.....	1
TEXT OF MANUAL.....	1-1

<u>Paragraph</u>	<u>Title</u>	<u>Page</u>
------------------	--------------	-------------

I - INTRODUCTION

1-01	AUTHORIZATION	1-1
1-02	PURPOSE AND SCOPE	1-1
1-03	RELATED MANUALS AND REPORTS	1-1
1-04	PROJECT OWNER	1-3
1-05	OPERATING AGENCY	1-4
1-06	REGULATING AGENCY	1-4

II - RESERVOIR DESCRIPTION

2-01	LOCATION	2-1
2-02	PROJECT PURPOSES	2-1
2-03	PHYSICAL COMPONENTS	2-1
2-04	RELATED CONTROL FACILITIES	2-2
2-05	REAL ESTATE ACQUISITION	2-3
2-06	PUBLIC FACILITIES	2-3

III - HISTORY OF PROJECT

3-01	AUTHORIZATION	3-1
3-02	PROJECT FORMULATION AND DESIGN	3-1
3-03	CONSTRUCTION	3-2
3-04	RELATED PROJECTS	3-3
3-05	MODIFICATIONS TO REGULATIONS	3-5
3-06	PRINCIPAL REGULATION PROBLEMS.....	3-5

TABLE OF CONTENTS
(Continued)

<u>Paragraph</u>	<u>Title</u>	<u>Page</u>
IV - WATERSHED CHARACTERISTICS		
4-01	GENERAL CHARACTERISTICS	4-1
4-02	TOPOGRAPHY	4-1
4-03	GEOLOGY AND SOILS	4-1
4-04	EROSION AND SEDIMENT YIELD	4-2
4-05	CLIMATE	4-2
4-06	STORMS AND FLOODS	4-3
4-07	RUNOFF CHARACTERISTICS	4-7
4-08	WATER QUALITY	4-7
4-09	CHANNEL AND FLOODWAY CHARACTERISTICS	4-8
4-10	UPSTREAM STRUCTURES	4-8
4-11	DOWNSTREAM STRUCTURES	4-8
4-12	ECONOMIC DATA	4-9
V - DATA COLLECTION AND COMMUNICATION NETWORKS		
5-01	HYDROMETEOROLOGICAL STATIONS	5-1
	a. Streamflow Stations	5-1
	b. Precipitation Stations	5-2
5-02	WATER QUALITY STATIONS	5-3
5-03	SEDIMENT STATIONS	5-6
5-04	RECORDING HYDROLOGIC DATA	5-6
5-05	COMMUNICATION NETWORK	5-6
5-06	COMMUNICATION WITH PROJECTS	5-7
5-07	WARNINGS	5-7
VI - HYDROLOGIC FORECASTS		
6-01	GENERAL	6-1
	a. Role of Corps	6-1
	b. National Weather Agency	6-1
6-02	FLOOD CONDITION FORECAST	6-1
6-03	CONSERVATION PURPOSE FORECASTS	6-6
	a. Requirements	6-6
	b. Methods	6-7
6-04	LONG-RANGE FORECASTS	6-7
	a. Requirements	6-7
	b. Methods	6-7
6-05	DROUGHT FORECASTS	6-7
	a. Requirements	6-7
	b. Methods	6-7
	c. Reference Documents	6-7
6-06	NORMAL CONDITION FORECASTS	6-8
	a. Requirements	6-8
	b. Methods	6-8

TABLE OF CONTENTS
(Continued)

<u>Paragraph</u>	<u>Title</u>	<u>Page</u>
VII - WATER CONTROL PLAN		
7-01	GENERAL OBJECTIVES	7-1
7-02	MAJOR CONSTRAINTS	7-1
7-03	OVERALL WATER CONTROL PLAN	7-3
7-04	STANDING INSTRUCTIONS TO DAMTENDER	7-4
7-05	FLOOD CONTROL	7-5
	a. Requirements	7-5
	b. Normal Plan	7-5
	c. Emergency Plan	7-6
7-06	RECREATION	7-7
7-07	WATER QUALITY AND LOW-FLOW CONTROL	7-8
7-08	FISH AND WILDLIFE	7-8
7-09	WATER SUPPLY.....	7-8
7-10	HYDROELECTRIC POWER	7-9
7-11	NAVIGATION	7-9
7-12	DROUGHT CONTINGENCY PLAN	7-9
7-13	FLOOD EMERGENCY ACTION PLANS	7-9
7-14	OTHER PLANS	7-10
7-15	DEVIATIONS FROM NORMAL REGULATIONS	7-10
7-16	RATE OF RELEASE CHANGES	7-12
VIII - RESULTS OF WATER CONTROL PLAN		
8-01	GENERAL	8-1
8-02	FLOOD CONTROL	8-1
	a. Hypothetical Floods	8-1
	1. Spillway Design Flood 1930	8-1
	2. Official Plan Flood	8-3
	3. Modern Spillway Design Floods	8-3
	4. Standard Project Flood	8-5
	b. Representative Floods	8-5
	c. Benefits	8-8
8-03	RECREATION	8-9
8-04	WATER QUALITY	8-9
8-05	FISH AND WILDLIFE	8-13
8-06	WATER SUPPLY	8-13
8-07	HYDROELECTRIC POWER	8-13
8-08	NAVIGATION	8-13
8-09	DROUGHT CONTINGENCY PLANS	8-14
8-10	FLOOD EMERGENCY ACTION PLANS	8-14
8-11	FREQUENCIES AND DURATIONS	8-14

TABLE OF CONTENTS
(Continued)

<u>Paragraph</u>	<u>Title</u>	<u>Page</u>
IX - WATER CONTROL MANAGEMENT		
9-01	RESPONSIBILITIES AND ORGANIZATION	9-1
	a. Corps Of Engineers	9-1
	b. OCE in Water Control Activities	9-1
	c. Great Lakes and Ohio River Division	9-1
	d. Huntington District	9-1
9-02	INTERAGENCY COORDINATION	9-4
	a. Local Press and Corps Bulletins	9-4
	b. National Weather Service	9-4
	c. U.S. Geological Service	9-5
	d. Ohio Department of Natural Resources	9-5
	e. Other Federal, State, or Local Agencies	9-6
9-03	INTERAGENCY AGREEMENTS, MEETINGS, AND ORGANIZATIONS	9-7
9-04	COMMISSIONS, RIVER AUTHORITIES, COMPACTS, AND COMMITTEES	9-7
9-05	HUNTINGTON DISTRICT REPORTS	9-8
	a. Periodic	9-8
	b. Special Reports	9-10

TABLES

<u>Number</u>	<u>Title</u>	<u>Page</u>
3-1	RESERVOIR POOL ELEVATIONS AND STORAGE.....	3-1
4-1	CLIMATIC SUMMARY - STILLWATER CREEK BASIN	T4-1
4-2	STILLWATER CREEK AT TIPPECANOE, OHIO - HIGH WATER DATA	4-4
4-3	MONTHLY AND ANNUAL AVERAGE RUNOFF, STILLWATER CREEK AT UHRICHSVILLE GAGE	4-7
5-1	STILLWATER CREEK BASIN STREAMGAGING NETWORK - PERTINENT DATA	T5-2
5-2	PRECIPITATION STATIONS IN AND NEAR STILLWATER CREEK BASIN - PERTINENT DATA	T5-3
5-3	DESCRIPTION BY LOCATION OF CLENDENING LAKE WATER QUALITY SAMPLING STATIONS	5-4
5-4	STANDARD PHYSICAL/CHEMICAL TESTS	5-5
5-5	CLENDENING LAKE FLOOD LEVEL WARNINGS	5-8

TABLES(cont.)

<u>Number</u>	<u>Title</u>	<u>Page</u>
6-1	CLENDENING LAKE POOL ELEVATIONS AND STORAGE	6-2
6-2	CONTROL FLOWS AND STAGES AT KEY RIVER STATIONS BELOW CLENDENING DAM	6-2
6-3	DRAINAGE AREAS FOR STILLWATER CREEK BASIN	6-4
6-4	THREE HOUR UNIT HYDROGRAPHS FOR CLENDENING LAKE	6-7
7-1	OPERATIONAL LIMITATIONS AND CONSTRAINTS	7-2
8-1	SPILLWAY DESIGN FLOOD.....	8-2
8-2	FREQUENCY SUMMARY BRUSHY FORK AT CLENDENING LAKE OUTFLOW GAGE	8-15
8-3	FREQUENCY SUMMARY CLENDENING LAKE POOL ELEVATION DEVIATION	8-15
9-1	HUNTINGTON DISTRICT REPORTS BY THE WATER RESOURCES ENGINEERING BRANCH	9-13

EXHIBITS

Number

- A-1. Supplementary Pertinent Data
- B. Standing Instructions to Damtender

ANNEXES

DROUGHT CONTINGENCY PLAN

Annex I

LIST OF PLATES

<u>Number</u>	<u>Title</u>
1-1	DISTRICT BOUNDARY
2-1	DRAINAGE AREA MAP
2-2	CLENDENING LAKE
2-3	CLENDENING DAM PLAN AND ELEVATION
2-4	EMBANKMENT DETAILS
2-5	SPILLWAY - PLAN AND PROFILE
2-6	APPROACH AND OUTLET CHANNELS
2-7	INTAKE - CONTROL WEIR
2-8	INTAKE SECTIONS - NO. 1
2-9	INTAKE SECTIONS - NO. 2
2-10	SERVICE BRIDGE
2-11	OUTLET WORKS
2-12	CONDUITS - PLAN AND PROFILE
2-13	CONDUITS - SECTIONS
2-14	STILLING BASIN - SECTIONS
2-15	OPERATING HOUSE - ELEVATIONS
2-16	LAND USE MAP
2-17	SUPPLEMENTARY PERTINENT DATA
4-1	HIGH WATER PROFILES
5-1	HYDROLOGIC NETWORK
5-2	SEDIMENTATION PROFILE - LAKE
5-3	SEDIMENT RANGES AND WATER QUALITY SAMPLING STATIONS
5-4	LINES OF COMMUNICATION
6-1	FORECAST AREA AND REACHES
6-2	CLENDENING LAKE - MUSKINGUM RIVER BASIN NETWORK CONFIGURATION
7-1	AREA AND CAPACITY TABLES
7-2	PERCENT STORAGE UTILIZATION
7-3	SIPHON RATING TABLE
7-4	SLUICE GATE RATING CURVES
7-5	SPILLWAY DISCHARGE CURVES
7-6	LAKE UTILIZATION CURVES

LIST OF PLATES
(continued)

<u>Number</u>	<u>Title</u>
8-1	FREQUENCY OF FILLING
8-2	DURATION OF FILLING
8-3	OFFICIAL PLAN FLOOD
8-4	SPILLWAY DESIGN FLOODS - INFLOW HYDROGRAPHS
8-5	FLOOD OF MARCH-APRIL 1913 AT CLENDENING LAKE
8-6	FLOOD OF AUGUST 1935 AT CLENDENING LAKE
8-7	FLOOD OF JANUARY 1937 AT CLENDENING LAKE
8-8	FLOOD OF JANUARY 1959 AT CLENDENING LAKE
8-9	FLOOD OF FEBRUARY-MARCH 1979 AT CLENDENING LAKE
8-10	FLOOD OF JULY-AUGUST 1980 AT CLENDENING LAKE
8-11	EMERGENCY DRAWDOWN CURVE
8-12	WATER TEMPERATURE PROFILE
8-13	DISSLOVED OXYGEN PROFILE
8-14	TOTAL IRON PROFILE
8-15	TOTAL MANGANESE PROFILE
8-16	OVERALL QUALITY RATING
9-1	WATER CONTROL MANAGEMENT - NORMAL ORGANIZATION
9-2	FLOOD EMERGENCY ORGANIZATION
9-3	RELATION WITH OTHER AGENCIES

CLENDENING LAKE

PERTINENT DATA

DAM

Type - Rolled earth fill with impervious core
Maximum height, feet.....64
Top length, feet.....950
Top width, feet.....20
Base width, feet.....460

SPILLWAY

Type - Uncontrolled saddle spillway at right
(west) abutment
Crest length, feet.....128
Crest elevation, feet above NGVD.....910.5
Design discharge, cubic feet per second.....13,200
Surcharge, feet.....13

OUTLET WORKS

Type - Intake structure with tunnel and stilling basin.
Intake structure - Reinforced concrete with horseshoe tunnel, siphons,
and control gates.
Siphons - To maintain seasonal pool, a 1'-6" diameter siphon is
located in each of the two outer sluices, in front of gates No. 1 and
3, discharging into the middle sluice below gate No. 2.

Invert elevation of siphons, feet above NGVD.....897.25
Number of control gates.....3
Size of control gates, feet.....3'6"x7'
Invert elevation of control gates, NGVD.....862
Maximum outlet discharge, cfs, at.....18-1900
spillway elevation, all gates open

TUNNEL

Type - Horseshoe, concrete lined
Number of tunnels.....1
Size, feet.....7'6"x8'
Length, feet.....473.5

STILLING BASIN

Type - Conventional jump type with a rising invert located between the
tunnel portal and the stepped portion of the apron, discharging onto
baffle blocks and an end sill. A small rectangular sluiceway at
tunnel exit elevation is provided thru the center of the rising invert
for drainage of the tunnel.

Width, feet.....33
Length including outlet transition, feet.....93.75

Note: Additional data can be found on Exhibit "A"

MUSKINGUM RIVER BASIN
OHIO

WATER CONTROL MANUAL
CLENDENING LAKE - BRUSHY FORK OF STILLWATER CREEK

SECTION I - INTRODUCTION

1-01. AUTHORIZATION

This manual is prepared in accordance with Engineer Regulation 1110-2-8156, Preparation of Water Control Manuals, dated 31 August 1995; Engineer Regulation 1110-2-240, Water Control Management, dated 30 April 1987; Engineer Manual 1110-2-3600, Management of Water Control Systems, dated 30 November 1987; and ETL 1110-2-251, dated 14 March 1980, which provides for submission of regulation manuals in accordance with instructions contained in "Guide for Preparing Water Control Manuals" as prepared by SWD, dated October 1977.

1-02. PURPOSE AND SCOPE

The purpose of this manual is to furnish detailed schedules for water control management of Clendening Lake. The manual will function as documentation of the plan for water control and as a reference source for higher authority and office and field personnel responsible for water control management throughout the life of the project. The manual also contains background information necessary for understanding the objectives and application of the water management schedules, as well as results of optimal simulation of project operation for specific purposes and conditions.

1-03. RELATED MANUALS AND REPORTS

The following manuals and reports concerning Clendening Lake or the Muskingum River projects have been previously completed.

<u>TITLE</u>	<u>DATE</u>
1. Report on main river in vicinity of mouth (Navigation)	1879
2. Report on main river (Navigation)	1884
3. Report on main river (Navigation)	1886
4. Report on main river, Zanesville to Dresden (Navigation)	1889
5. Report on main river, Zanesville to Dresden (Navigation)	1895
6. Report on main river from Zanesville to Coshocton (Navigation)	1902

RELATED MANUALS(cont.)

<u>TITLE</u>	<u>DATE</u>
7. Report on main river in vicinity of the mouth (Navigation)	1905
8. Report on main river and all tributaries (flood control)	1916
9. Report on Mohican River and tributaries (flood control)	1931
10. Official Plan for the Muskingum Watershed Conservancy District, Volumes I and II	October 1934 Amended April 1935 Revised June 1935
11. Muskingum River 308 Report	December 1934 Revised January 1942
12. Comprehensive report on reservoirs in Mississippi River Basin	August 1935
13. Ohio River 308 Report	August 1935
14. Major Dams and Hydro-Projects in the Huntington, West Virginia and Zanesville, Ohio Engineer Districts	November 1937
15. Analysis of Design - Clendening Lake	Revised 1937
16. Analysis of Design - Addenda	1938
17. History and Development of the Muskingum Watershed Conservancy District Project	March 1938 Revised March 1939 Revised July 1952
18. Analysis of Hydrologic Data for Index Areas - Muskingum River Basin, Ohio	April 1942
19. Flood Control Operation - Flood of Dec. 1942-Jan. 1943 - Muskingum River Reservoirs, Ohio	February 1943
20. Channel Capacity Investigation Muskingum River, Ohio	May 1944
21. An Experience History of the Muskingum River Reservoir System	October 1951
22. Instructions to Project Supervisor, Clendening Lake Dam	November 1953 March 1954
23. Water Inventory of the Muskingum River Basin and Adjacent Ohio River Tributary Area	1968
24. Muskingum Area, Emergency Operations Plan	March 1970

RELATED MANUALS(cont.)

<u>TITLE</u>	<u>DATE</u>
25. Periodic Inspections, Clendening Lake Dam:	
Report No. 1	March 1970
Report No. 2	May 1976
Report No. 3	June 1979
Report No. 4	May 1984
Report No. 5	March 1989
Report No. 6	May 1994
Report No. 7	June 1999
26. Post-Flood Report, Muskingum River Basin, Ohio - Flood of July 1969	April 1970
27. Operations and Maintenance Manual - Clendening Lake	January 1973
28. Muskingum River Basin, Ohio - Basin Report	September 1973
29. Muskingum River Dams, Spillway Adequacy Study - Dodson Lindblom Inc.	April 1975
30. Muskingum River Basin, Ohio - Interim Feasibility Report for Water Resources Development	November 1975 Revised March 1976 Revised Feb. 1977
31. Muskingum River Reservoirs General Plan of Reservoir Regulation	October 1976 Revised Oct. 1984
32. A Valley Renewed - The History of the Muskingum Watershed Conservancy District	1976
33. Southeast Ohio Water Plan	September 1978
34. Dam Safety Training Program Manual, Clendening Lake	1983

1-04. PROJECT OWNER

The United States Government has full title, ownership, and fee control of all Corps of Engineers reservoir and lake lands, including Clendening Dam and operating structures. The Huntington District Corps of Engineers boundary map showing the location of all the district flood control projects is shown on **Plate No. 1-1.**

1-05. OPERATING AGENCY

The U. S. Army Corps of Engineers, Huntington District, Operations and Readiness Division controls the operation, regulation, and maintenance of the Clendening Lake project. To ensure correct operation Clendening Lake is staffed, all year round, Monday thru Friday between the hours of 0730 and 1600, and the project is monitored during non-duty hours when conditions warrant it and if necessary, operations will be made during non-duty hours.

In conformance with the Ohio River Division Regulation 1110-2-27, dated 12 January 1976, the Water Resources Engineering Branch of the Huntington District has the primary responsibility for overall water control management of all Huntington District projects and associated reservoir activities, technical evaluations and performance of operations of these projects, and for developing plans and manuals for the reservoir systems within the District, including the Clendening Lake project.

1-06. REGULATING AGENCY

The regulation of Clendening Lake is under the supervision of the Water Management Section of the Water Resources Engineering Branch of the Huntington District. Any operations which might deviate from the approved water control plan, as presented in this manual must be coordinated with the Great Lakes and Ohio River Division Reservoir Control Center.

The operating and regulating responsibility is exercised under the following regulations:

- (1) EM 1110-2-3600, 25 May 1959, Subject: Reservoir Regulation;
- (2) ER 1110-2-1400, DAEN-CWE-Y, 24 April 1970, Subject: Reservoir Control Centers;
- (3) ORDR 1110-2-27, 12 January 1976, Subject: Water Control Management Activities;
- (4) ER 1130-2-415, DAEN-CWE-Y, 28 October 1976, Subject: Water Quality Data Collection, Interpretation, and Application Activities;
- (5) ORDR 1110-2-26, 5 February 1979, ORDED-W, Subject: Water Quality Investigations and Control Activities;
- (6) ER 1110-2-208, DAEN-CWE-Y, 30 July 1979, Subject: Water Control Management; and
- (7) ER 1110-2-240, DAEN-CWE-Y, 8 October 1982, Subject: Water Control Management.

SECTION II - DESCRIPTION OF PROJECT

2-01. LOCATION

Clendening Lake is located in Harrison County, Ohio on Brushy Fork of Stillwater Creek, a tributary of the Tuscarawas-Muskingum Rivers, about 0.5 mile east of Tippecanoe and 9 miles southeast of Uhrichsville. The damsite is located near the eastern edge of the Muskingum River Basin watershed, about 184.4 miles above the mouth of the Muskingum River, and approximately 1.3 miles upstream from the mouth of Brushy Fork.

An aerial view of the lake is shown on page number ii. The Drainage Basin Maps, **Plate No. 2-1** and **2-2**, show the project location and other major features. Clendening Lake basin is somewhat rectangular-shaped lying in a general east-west direction, draining about 69 square miles.

2-02. PROJECT PURPOSES

The Clendening Lake Project was authorized for flood control and allied purposes in a comprehensive plan for both the Muskingum and Ohio River Basins. Project purposes include flood control, water conservation, general recreation, and conservation of fish and wildlife. Benefits from specific project purposes serve not only local interests in the Tuscarawas and Muskingum River Basins, but are widespread throughout the Ohio River Basin. Land use for the various project purposes are shown in a later portion of this section. Pertinent data for the Clendening Lake Project is shown as **Exhibit-A**.

2-03. PHYSICAL COMPONENTS

a. General. Flood control structures at Clendening Lake include a rolled earth and rockfill embankment with an uncontrolled saddle spillway located beyond the west abutment. The outlet works are located upstream from the west abutment. General details of the dam and outlet works are shown on **Plate Nos. 2-3** and **2-4**.

b. Embankment. The embankment is a rolled earth and rockfill structure with an impervious clay core. The embankment slopes steepen progressively from 10 horizontal to 1 vertical near the upstream and downstream toes to 2V to 1H near the centerline of the dam. The embankment contains two random zones of crushed sandstone and weathered shale and exterior shells of unweathered sandstone and firm shale. An exploration trench, a downstream rock toe drain and filter blanket, a key wall, and grout curtains in both abutments are design features that help control seepage. Embankment details are shown on **Plate No. 2-5**.

c. Spillway. The spillway is located approximately 230 feet northwest of the west abutment of the dam and consists of an uncontrolled, unlined saddle having a crest length of 128 feet at elevation 910.5 NGVD. The outlet channel is cut through the right abutment and is approximately 550 feet long and 60 feet wide. A two-lane bridge spans the spillway saddle, allowing access to the operating house. The spillway design discharge crest is 13,200 cfs with a surcharge of 13 feet and a freeboard of 2 feet. Details of the spillway are shown on **Plate Nos. 2-6**, and details of the spillway bridge are shown on **Plate No. 2-7**.

d. Outlet Works. The outlet works is located upstream from the

west abutment, and consists of an approach channel, intake structure, 500-foot tunnel, stilling basin and outlet channel. To maintain the conservation pool, a 1'6" diameter siphon is located in front of the gates in each of the two outer conduits, discharging into the middle conduit below the gates. General details of the outlet works are shown on **Plate No. 2-8**.

The intake structure consists of a reinforced concrete substructure, and a brick and stone superstructure which houses the gate operating machinery. Access to the operating house is by means of a steel and concrete service bridge. The intake structure contains three 3'6"x7'0" rectangular inlets, with appropriately sized slide-type control gates, which discharge into a 8'0" x 7'6" horseshoe tunnel. The horseshoe tunnel is 500 feet in length with a transition section between the gates and tunnel portal. The section immediately downstream from the gates is lined with cast iron thimbles to protect against cavitation. Details of the operating house, intake plan and elevations, intake plan and sections, intake - sections, and intake details and service bridge are shown on **Plate Nos. 2-9** through **2-13**.

The stilling basin is a reinforced concrete structure of conventional jump design with 18-foot high gravity walls. The floor slab is anchored into rock. Drain holes 4 feet into rock are provided to relieve uplift pressure. Baffle piers and an end sill were constructed for energy dissipation. Details of the stilling basin are shown on **Plate Nos. 2-14** and **2-15**. Clendening Lake project pertinent data is on **Plate No. 2-16**.

The outlet channel is crossed by a single span, two-lane highway bridge, designed and constructed by the State of Ohio. No construction records or drawings are available for the highway.

e. Operating Machinery.

(1) Slide Gates. The three sluice gates for the 3.5'x 7.0' conduits are raised and lowered by means of a threaded shaft and geared revolving nut driven by a 7.5 hp, 220 volt AC, 3 phase, 60 Hertz electric motor. The hoist is controlled by a magnetic reversing controller which is energized by the RAISE-STOP-LOWER push button control assembly mounted on the hoist. A gate position indicator is located on the gate stem extension cover, visible from the operator position at the controls. Each hoist circuit is energized by a fused knife-switch, mounted on the switch board. In the event of a power failure, including the stand-by generator, the sluice gates can be operated by the use of a hand crank. A single emergency gate is stored in one of three emergency gate wells, and is placed using a 10-ton overhead crane which is located in the operating house.

(2) Auxiliary Power Unit. The standby emergency generator sufficient for emergency needs is located [REDACTED]. The AC generator is driven by a 6 - cylinder gasoline engine that provides emergency power at 220/120 volts, 3 phase, 60 Hertz, at 31 KVA, with a maximum current rating of 82 amperes.

2-04. RELATED CONTROL FACILITIES

Clendening Lake is operated in conjunction with all the flood control reservoirs in the Muskingum system. There are two other flood control reservoirs in the Stillwater Creek Basin, Piedmont Lake on upper Stillwater Creek, and Tappan Lake on Little Stillwater Creek. Upstream of New Philadelphia, Dover Dam is the largest with three tributary

reservoirs, Atwood, Leesville, and Bolivar Lakes. Just below New Philadelphia on Sugar Creek is Beach City Lake. In addition there are nine more projects in nearby segments of the Muskingum River Basin. All of these lakes are operated as a unit to reduce flooding along Stillwater Creek, and the Tuscarawas, Walhonding, and Muskingum Rivers.

2-05. REAL ESTATE ACQUISITION

Land purchases for the project were initiated in 1935 by the Muskingum Watershed Conservancy District. Lands needed for construction were purchased initially, followed by those lands that would be most susceptible to flood damage due to the operation of the dams. The money for these purchases came from state-appropriated funds and the sale of Conservancy District warrants issued in anticipation of the assessments to be made on improved protected property. Lands purchased in fee title generally included all lands within the limits of the conservation pool level, all lands needed for construction, those lands near the conservation pool level on which the directors wished to control development, and lands that would be subject to frequent flooding due to the retention of floodwaters behind the dams. In cases where a large portion of a farm unit was subject to flood inundation, the whole farm unit was purchased in fee title. Flowage easements were acquired on properties above the conservation pool level. In the Clendening Lake area, the Muskingum Watershed Conservancy District owns approximately 6,550 acres in fee title, and the U.S. Army Corps of Engineers owns approximately 86.5 acres at the damsite in fee title. The Corps of Engineers has also acquired flowage easements on approximately 7,214 acres at Clendening Lake. The limits of acquired lands at Clendening Lake are shown on **Plate No. 2-17**, Land Use Map.

2-06. PUBLIC FACILITIES

Clendening Lake is unique among the Muskingum River Basin lakes in that the Official Plan for Parks and Recreation calls for the Clendening Lake recreational area to remain in an undeveloped "natural" state with no land leases and only a few access points permitted. Recreational facilities at Clendening Lake include boat rental, bait, picnic sites, campsites, cottages and food service. Recreational activities at Clendening Lake include fishing, boating, sailing, canoeing, picnicking, camping, hunting, and trapping.

Clendening Lake provides 70 campsites in quiet, secluded wooded areas. Electricity is available for campers as well as pads and picnic tables. The marina is located at the approximate mid-point of the reservoir, just off State Route 799. Facilities at the marina include a motel, free boat launching ramp, pay docking, boat and motor rental and sales, lunch counter, tackle, bait, supplies, and camping. There is also a free boat launching ramp located off County Road 6 near the west (downstream) end of the reservoir. A picnic area with tables is located near the dam. The maximum horsepower allowed for boating on the lake is 10 horsepower. Where Muskingum Watershed Conservancy District ownership permits, a 100-foot wide strip of land adjacent to the 44 miles of shoreline is perpetually dedicated to public use. The Clendening Lake recreational facilities are shown on the Land Use Map, **Plate No. 2-17**.

SECTION III - GENERAL HISTORY OF THE CLENDENING LAKE PROJECT

3-01. AUTHORIZATION

Clendening Lake is one of a system of 14 original reservoir projects in the Muskingum River Basin which were constructed in cooperation with the Muskingum Watershed Conservancy District in the 1930's. The Public Works Administration approved a general project plan developed by the Conservancy District and allocated funds to the Corps of Engineers to aid in financing the supervision and construction of the project.

The Flood Control Act of 1939 contained a provision that the Muskingum River Basin dams and reservoirs be included in the comprehensive flood control plan for the Ohio River Basin. The operation and maintenance of the dam and appurtenances of Clendening Lake on Brushy Fork of Stillwater Creek has been the responsibility of the Corps of Engineers since that date. The Muskingum Watershed Conservancy District owns the waters of Clendening Lake, and leases the waters to the State of Ohio for fish and wildlife enhancement.

3-02. PROJECT FORMULATION AND DESIGN

Several dam sites, including Clendening Lake, were considered for the Stillwater Creek Basin. The most effective control would have been provided by a dam located at Tippecanoe, which could have controlled 280 square miles of Stillwater Creek. However, the cost of railroad relocation in the valley was prohibitive. Therefore, three smaller dams in the Stillwater Creek watershed were selected; Clendening Lake on Brushy Fork near Tippecanoe, Tappan Lake on Little Stillwater Creek near Tappan, and Piedmont Lake on upper Stillwater Creek near the village of Piedmont. In addition to the flood control storage provided at these three dams, it was found economical to include large amounts of water conservation at each site because of the relatively low right-of-way cost. The structure and outlet works at Clendening Lake were designed to provide sufficient capacity to store 7.5 inches of runoff from the watershed between the conservation pool and emergency spillway crest elevations. Clendening Lake pool and storage data are shown below on **Table No. 3-1.**

TABLE NO. 3-1 CLENDENING RESERVOIR POOL ELEVATIONS AND STORAGES						
Pool	Surface Elevation	Area Acres	Acre-feet		Storage	
			Net	Gross	Inches runoff Net	Gross
Minimum Pool:						
Summer	898.0	1,800	26,500	26,500	7.2	7.2
Winter	893.0	1,430	18,500	18,500	5.0	5.0
Flood Control:						
Summer	910.5	2,620	27,500	54,000	7.5	14.7
Winter	910.5	2,620	35,500	54,000	7.5	14.7
TOTAL	910.5	2,620		54,000		14.7

3-03. CONSTRUCTION

Private contractors, who performed construction under the Corps supervision were required to employ as many laborers as possible from relief rolls, because an important project purpose was to aid in recovery from the National Depression. The contract for the construction of the dam was awarded to R. Giavina of Charleston, West Virginia, and construction began in the spring of 1935. Very soon, another disastrous record summer flood occurred in August 1935 which devastated most of the agriculture in central Ohio. The vast damage from this flood caused even more people to support any possible method for flood control. Several major changes were required during the construction period, resulting in an extension of the completion date to 30 August 1936. Due to problems experienced during the early stages of construction, the contract of R. Giavina was terminated, and was later assumed by S. W. Ritchie of Boso & Ritchie, Ravenswood, West Virginia.

During construction of the outlet works, flow was maintained in the existing stream channel. After the outlet works were completed, an upstream cofferdam was constructed, and the water was diverted through the outlet works. A downstream cofferdam was also constructed to protect the embankment from backwater.

Excavations in the intake area of the outlet works revealed foundation material at a higher elevation than had been anticipated. Accordingly, the lower portion of the concrete foundations for the intake wingwalls were eliminated resulting in improved design and economy. Excavation for the proposed west keywall disclosed a sufficient thickness of impervious overburden to warrant elimination of the keywall. The primary portion of concrete for the intake structure, tunnel and stilling basin was placed between July 1935 and May 1936. Concrete for the east keywall was placed between 11-18 June 1935. Concrete for the intake service bridge and spillway bridge was placed between September 1936 and May 1937.

Construction for the embankment was started in the spring of 1935. As construction progressed, movements in the fill were noted, primarily on the upstream side, requiring a revision in the embankment design to utilize flatter slopes. Despite the precautions taken, the movements continued, accelerating in November 1936 and again in February 1937. The embankment ruptured shortly thereafter. After the failure, additional rock was added to the upstream slope which prevented additional movement, and the embankment was completed without further incident.

The embankment design required foundation seepage to be controlled by the layer of low permeability silty clay which exists in the natural overburden. As an additional means of controlling foundation seepage, a downstream filter blanket was installed during 1976. In 1971 a double row grout curtain was placed in both abutments which significantly reduced seepage through the right abutment.

Relocations necessary for the construction of Clendening Lake included 3.9 miles of telephone lines, 0.1 mile of electric power lines, 0.2 mile of gas lines, and 10.6 miles of secondary roads. The stilling basin at the outlet works of the dam necessitated the construction of a bridge on County Road 69.

The total cost of the project was \$1,160,100 which included portions of the cost of preparation of the Official Plan.

3-04. RELATED PROJECTS

A report compiled but not published, House Document No. 306, 74th Congress, first session - the unprinted Ohio River "308 Report, planned for a total of 39 flood control reservoirs to be built for the Ohio River Basin and its tributaries. The fourteen reservoirs under construction by the Corps of Engineers for the Muskingum Watershed Conservancy District were substituted for first 16 anticipated Muskingum Basin projects in this report. Justification for substitution of the 14 reservoirs was presented in a report of the Board of Engineers for Rivers and Harbors, included in House Document No. 306. After due consideration, the original Muskingum system was then accepted by the Corps of Engineers and Congress. The Licking River, or Dillon Reservoir Project Report, dated June 1939, was subsequently prepared and submitted to the Chief of Engineers for review and approval. The original 14 Muskingum Reservoirs sites are shown as **Plate No. 1-1**.

The original 14 reservoirs were completed by 1938, dedicated, and the structures and facilities were deeded to the Corps of Engineers for operation on 11 August 1939 at a cost of about \$41 million dollars. Total project cost was well over the original estimate. Final settlement of cost distribution was not resolved until October 1955, although construction of the original project was completed in 1938. The MWCD retained about 36,190 acres of land adjoining the projects and were left with a final obligation of only about \$1.5 million because of changes in Federal law regarding requirements for local participation in flood control projects. The State of Ohio contributed \$7 million dollars in highway relocations and cash.

The outbreak and intervention of Pearl Harbor and World War II postponed any further action for the duration of the war. Due to World War II construction of any large project like Dillon or Frayzesburg Dam or any local protection project was again deferred until peace time, with all national effort and money going to war production. During the intervening war years the design plans for Dillon Dam were changed somewhat with the spillway being moved and the outlet works redesigned.

The Muskingum Reservoir system now has sixteen reservoirs and five local protection projects with a total of 1,604,000 acre-feet of storage and 5,020 square miles of controlled drainage area or 62.5 percent of the total basin. The partially completed 14 dams were used for the first time in the great Ohio valley flood of 1937 and in the next 60 years accumulated \$1.915 BILLION DOLLARS in flood damages prevented.

Dillon Dam was completed in 1961 at a cost of about \$30 million dollars and has accumulated benefits amounting to \$274 MILLION DOLLARS in 36 years. North Branch of Kokosing River Lake was completed in 1972. For the five years period (91-95) the 16 reservoir system accumulated annual flood damages prevented would be \$86.5 million dollars per year. These damage and benefit figures are shown in Section IV.

The final post war phase of development in the Muskingum Basin was the solid growth of recreation and vacation resorts at the many lakes and rivers in the area. This led to the creation of the Ohio Department of

Natural Resources in 1949 and they have coordinated with the Corps of Engineers on many water projects in this final phase of water resources and recreation development. This phase was only lightly considered when the original Muskingum Reservoirs were built, but the Muskingum Water Conservancy District later built and developed elaborate facilities that draw enormous crowds at the lake resorts during the summer which has produced a new industry for the basin called tourism and recreation.

The summary and final phase of Muskingum water resources development is that many public and private groups now use the multi-purpose water projects of the Muskingum Basin that were developed by the Corps of Engineers, Muskingum Water Conservancy District, and Ohio Department of Natural Resources. The vital personal and urban water supply of about 115 cities, towns, and units within the basin now come from both underground and surface streams and lakes. The 115 unit municipal water consumption for each day in the basin was about 85 mgd or 132 cfs in 1960. This very basic need for municipal water supply is expected to more than triple to 260mgd or 400 cfs by the end of the century. Several water supply lakes have been built by the state such as Buckeye, Knox, Nimishilla, Portage, Salt Fork, and Veto. Mansfield and Barberton have built Clear Fork Lake and Barberton Reservoir and Dorothy Lake. Private interests have built and developed Buckhorn Lake and Chippewa Lake. Surface waters are also used by railroad, coal, mining, manufacturing, and lumbering industries for producing steam, processing material, and washing coal. The total water consumption from the Muskingum Basin in 1960 was about 2,037 mgd or 3,150 cfs, of which 94 percent goes to power plants. In addition, about 73 cities and towns in the basin also have a municipal sewerage treatment plant designed to treat the sewage equivalent of 996,000 people. This capacity is expected to triple by the year 2020. The combined effort of safe water treatment and sewerage treatment plants has reduced the number of deaths from Typhoid fever remarkably. However, there is still a strong need for additional water supply each summer for optimum crop growth in the watershed.

Future studies of the Muskingum Basin include the possibility that the basin will be reviewed on a regular basis for possible water resources and recreational development. The Corps of Engineers has made or contracted flood plain studies for many counties in the State Of Ohio and the basin. These include Flood Insurance Studies, Frequency Profile Studies, Inundation layouts, and Dam Break studies. The future of the Muskingum Basin will probably include more counties and cities participating in the FEMA or Flood Plain Protection Program.

3-05. MODIFICATIONS TO REGULATIONS

The expansion of the downstream cities of Tippecanoe, Uhrichsville, and Denison, Ohio, has created serious encroachment on the flood plain of Stillwater Creek.

3-06. PRINCIPAL REGULATION PROBLEMS

The settlement and expansion of the Muskingum River Basin began with the landing of the "Adventure Galley or Mayflower" at Marietta over 200 years ago. The economic, industrial, and water resources expansion and development of the basin began immediately and continues today. The future of the Muskingum Basin and the State of Ohio has always been linked with extensive water resources development. The Muskingum Basin was the nations first in basin wide planning for flood control, water conservation, and water resources development and will always be first in Ohio for planning the future.

SECTION IV - WATERSHED CHARACTERISTICS

4-01. GENERAL CHARACTERISTICS

The Brushy Fork Basin of Stillwater Creek lies entirely within Harrison County in eastern Ohio. The basin is elongated and irregular in shape with a length of approximately 14 miles, a maximum width of approximately 6 miles, and has a drainage area of about 70 square miles. The drainage area map is given in **Plate No. 2-1**.

Stillwater Creek is one of four large tributary streams flowing into the Tuscarawas River. Stillwater Creek lies on the eastern rim of the Tuscarawas - Muskingum Basin between Conotton Creek on the north and Wills Creek on the south, and enters the Tuscarawas River about 13 miles below Dover Dam and New Philadelphia. Little Stillwater Creek and Brushy Fork are the two main tributaries in the Stillwater Creek Basin; each stream has a small reservoir, plus further upstream on main Stillwater Creek is Piedmont Lake. Brushy Fork lies in the eastern sector of the Stillwater Basin, and flows northwesterly to westerly to its confluence with Stillwater Creek, approximately 1.3 miles downstream of Clendening Lake. From the headwaters at elevation 1192 NGVD to the dam at Clendening Lake, Brushy Fork has a total fall of approximately 334 feet in a distance of about 21.3 miles. This represents an average slope of 14.8 feet per mile. Its major tributaries are much steeper, ranging from 48.3 feet per mile for McFadden Run to 89.0 feet per mile for Long Run. The stream profile of Brushy Fork is shown on **Plate No. 4-1**.

4-02. TOPOGRAPHY

The Brushy Fork watershed lies in the unglaciated portion of the Allegheny Plateau Physiographic Province in the eastern portion of the Muskingum River Basin. The area is comprised of a very well dissected typical Appalachian terrain with rugged hill country and broad valleys along the major streams. It is apparent that many of the valleys are too wide to be the work of the streams that occupy them at the present time, and that they were cut by pre-glacial streams of far greater magnitude. The highest ridges in the watershed are at approximately 1300 feet above NGVD, with a total relief of approximately 500 feet.

4-03. GEOLOGY AND SOILS

The consolidated rocks now appearing at the surface in the Muskingum drainage area above Zanesville are of sedimentary origin and belong to the Mississippian and Pennsylvanian periods. They dip to the southeast at the rate of about 20 feet to the mile. The Pennsylvanian formations overlie the Mississippian and occupy the eastern two-thirds of the watershed. They are made up of sandstone, shale, and coal with a few thin beds of limestone. The Clendening Lake damsite is underlain by Pennsylvanian rocks.

The valley fill at the Clendening Lake damsite is approximately 100 feet thick and consists of a heavy blanket of clay and silt overlaying sandy silt and fine sand. These overlaying materials as a whole are fairly impervious. The rock materials in the valley walls consist of horizontal beds of sandstone and shale of the Conemaugh formation. The spillway structure is located in the right valley wall. The spillway base is made up of medium-hard sandstone down to elevation 850 feet NGVD, with an underlying layer of firm sound shales. The left wall is composed of

medium-hard sandstone above elevation 868 feet NGVD, underlain by shale, which grades downward into interstratified sandstone and shale.

Soils in the Clendening Lake watershed are mainly of the Gilpin-Guernsey-Keene Association. These soils are well to moderately well drained, moderately deep to deep upland soils which are unglaciated and underlain by siltstone and limy and non-limy shales. The extreme upper portion of the watershed is dominated by soils of the Strip Mine Spoil-Guernsey-Westmore Association. A major part of this association has been influenced by strip mining operations for coal. The remainder of the association consists of moderately deep to deep soils on sloping to very steep uplands and foot slopes. The strip mine spoil is mostly clayey texture and is medium acid to alkaline in reaction.

Soil erosion and steepness of slope are the major management problems associated with both soil associations. Much of the land within the watershed is too steep for cultivation; therefore, a relatively high proportion of the land is in forest or pasture. Land use in the basin was mostly soil and pasture, but the Clendening Lake watershed has become a major source of surface mining activity.

4-04. EROSION AND SEDIMENT YIELD

Erosion from a watershed depends on a number of factors, including precipitation, physiography, land use, and size and shape of the drainage basin. Precipitation loosens the soil particles from the earth, the first process in the erosion-sedimentation process. The highest concentrations of sediment are created by high-intensity rainfalls with large-sized raindrops. Steep sloping land produces more erosion than gently sloping land. Greater sediment production occurs from land with poor vegetative cover. Large drainage basins generally produce less sediment per square mile from a given storm than a small basin produces because of the variability of slopes and rainfall in the large basin. The shape of the drainage basin is an indicator of sediment production, as sedimentation can occur in available bottom lands before it reaches the reservoir.

Brushy Fork lies in a very steep unglaciated basin with areas of strip-mine operations, which creates a high potential for severe erosion and high sedimentation at Clendening Lake. This potential has been reduced; however, by strip-mine reclamation and reforestation programs in the watershed. As a part of the Muskingum Watershed Conservancy District's reforestation program, soils in the Clendening Lake and other Muskingum River Basin project basins are being conserved and restored. Erosion of slopes and siltation in the lakes is reduced as a result of the program. More than 12 million trees have been planted to date in the Muskingum River Basin by the Muskingum Water Conservancy District, and more are planted every year.

4-05. CLIMATE

a. General. Southeastern Ohio has a generally humid continental climate, with short periods of extreme heat and cold. It is in the path of rain producing storms which move across the nation from west to east. The storms often converge in the Great Lakes region and leave by way of the St. Lawrence River valley; thusly, the southern half of Ohio is visited more frequently by productive rainstorms. The lifting of moist air masses over the hilly terrain tends to increase the yield of rainfall, especially in winter and spring. Extreme amounts

of precipitation and long periods of drought are relatively uncommon. Climatological data for three representative locations in or near the Clendening Lake Basin are presented in **Table No. 4-1**, Table section.

b. Temperature. There are no climatological stations within the Clendening Lake Basin which record temperature data. Cadiz, which is located just east of the Clendening Lake Basin, has a mean annual temperature of 51.4°F. The coldest month is January with a mean monthly temperature of 29.1°F and the warmest month is July with a mean temperature of 72.4°F. The growing season at Cadiz is approximately 166 days and extends from early May to the middle of October.

c. Precipitation. Precipitation within the Clendening Lake Basin is measured at the dam at Clendening Lake. Normal annual precipitation is 39.83 at Clendening Lake, with monthly normals ranging from 2.43 inches in February to 4.29 inches in July. Snowfall data is also measured at Clendening Lake, where the normal annual snowfall is approximately 34.5 inches.

d. Evaporation and Wind. At most Muskingum River Basin lakes, the amount of water lost by evaporation is quite small. The amount of loss attributable to evaporation from the lake itself is the difference between actual evaporation from the lake surface and the evapotranspiration from the same area before the reservoir was constructed. The average annual evaporation from Clendening Lake is approximately 32 inches. Comparison of the water surface evaporation with the water loss shows that the average increase in loss, or augmented evaporation due to a reservoir, is about seven or eight inches per year.

Prevailing winds in the area are from the south and southwest for most of the year; in February and March prevailing winds are from the northwest. The mean annual wind speed, based on data from the Akron-Canton Airport is 9.9 miles per hour. The maximum mean monthly wind speeds average between 11 and 12 miles per hour during the period November through April; minimum mean monthly wind speed is 7.4 miles per hour in August. Damaging windstorms are mostly associated with heavy thunderstorms, squall lines, or intense large area storms.

4-06. STORMS AND FLOODS

a. General. Flooding in the Muskingum River Basin generally occurs as the result of either high intensity precipitation or precipitation of unusual duration and extent. Floods may also result from a series of storms that follow one another in rapid succession, or by rains falling on snow covered ground. At times, flood conditions can be caused or aggravated by ice jams. General flooding in the basin occurs most frequently during the winter or early spring, but it can occur at any time of the year.

The flooding characteristics of Brushy Fork and the Stillwater Creek basin can be partially described by comparing the highest annual historical floods. These crests are shown in **Table No. 4-2**, next page, for the Stillwater Creek at Tippecanoe gage for water years 1923-1983. The Tippecanoe gage is located approximately 0.5 mile downstream from Brushy Fork, and the Uhrichsville gage is located at the Dennison Water Company Dam. The pre-construction 1936 flows are natural, based on a drainage area ratio from the Uhrichsville gage; the post 1936 flows are the recorded flows on Brushy Fork and Stillwater Creek with the regulation of Clendening and Piedmont Lakes. Annual peaks in the table

have been selected based on the water year period of October through September. Where the water year and calendar year do not coincide, the water year has been converted to a calendar year date in the table. **Table No. 4-2** below, spans 60 years, but only the 42 crests above 1970 cfs are shown. The original list of 60 floods plus 1913 is divided with 21 floods above 3,000 cfs and 39 of 60 below the 3,000 cfs level; basically due to the effect of the upstream reservoirs. Of the 21 highest annual crests, 8 are pre-construction occurring in 15 years, 1923-1937; while 13 are post 1936, occurring in 45 years, 1938-1983.

**TABLE NO. 4-2
STILLWATER CREEK AT TIPPECANOE, OHIO
MAXIMUM ANNUAL RECORDED FLOWS**

<u>Date</u>	<u>Gage Height (feet)</u>	<u>Discharge (cfs)</u>
Mar 1913.....		9,000*
8 Aug 1935.....		5,850*
27 Jan 1937.....		5,430*
5 Mar 1963.....	17.29.....	4,410
27 Mar 1945.....	17.26.....	4,410
16 Mar 1933.....		4,360*
16 Dec 1928.....		4,300*
11 Mar 1964.....	17.03.....	4,220
23 Jan 1927.....		3,990*
20 Apr 1940.....	16.78.....	3,970
27 Jan 1952.....	16.60.....	3,900
28 Feb 1936.....		3,680*
4 Dec 1950.....	16.24.....	3,600
15 Feb 1948.....	15.97.....	3,500
25 Feb 1975.....	15.99.....	3,440
7 Jan 1950.....	15.84.....	3,300
27 Feb 1979.....	16.01.....	3,240
20 Nov 1929.....		3,200*
1 Mar 1924.....		3,146*
16 Aug 1980.....	16.54.....	3,140
13 Apr 1981.....	16.43.....	3,060
11 Feb 1959.....	15.47.....	3,050
9 Jun 1978.....	15.33.....	2,730
9 Jun 1947.....	15.36.....	2,670
27 Apr 1961.....	14.84.....	2,590
14 Feb 1966.....	14.83.....	2,580
21 Mar 1943.....	14.72.....	2,560
25 Apr 1970.....	14.78.....	2,550
7 May 1971.....	14.77.....	2,540
7 Mar 1967.....	14.75.....	2,520
4 Apr 1977.....	14.75.....	2,520
10 Apr 1942.....	14.68.....	2,500
19 Oct 1975.....	14.74.....	2,420
6 Mar 1955.....	14.50.....	2,350
15 Apr 1949.....	14.04.....	2,280
16 May 1983.....	14.73.....	2,140
9 Apr 1944.....	13.62.....	2,080
25 Feb 1962.....	14.05.....	2,040
29 May 1956.....	13.99.....	2,000
5 Apr 1957.....	13.95.....	2,000
19 Apr 1939.....	13.53.....	1,980
25 May 1968.....	13.97.....	1,980
30 Dec 1940.....	13.65.....	1,970

*Natural flows based on drainage area ratio from Uhrichsville gage prior to 1936; after 1936, maximum recorded flows at Tippecanoe modified by Clendening and Piedmont Lakes.

b. Storm and Flood of March 1913. The storm causing this flood was general over the northern half of the Ohio River Basin, with the

heaviest precipitation in the States of Indiana and Ohio. Rainfall of 1 to 1.5 inches occurred on 20 and 21 March throughout the Ohio Valley and thoroughly saturated the ground, so that an unusually large percentage of subsequently heavy rain of the main storm, on 23 to 27 March, produced rapid runoff. All flood records on the southerly flowing tributaries of the Ohio River in Ohio and Indiana were broken.

In the Muskingum River Basin the main storm commenced just before noon on 23 March, with the rain becoming increasingly heavy for the next two days, and then continued on the 26th and in some portions of the basin also on the 27th. The total rainfall during the five days, most of which occurred in a period of 96 hours or less at individual points, averaged 6.55 inches over the Tuscarawas River Basin. No rainfall measurements are available within the Clendenning Lake Basin, but just east of the basin at Cadiz, rainfall for the 5-day period was 5.67 inches. As a result of the exceedingly heavy rain falling on ground already saturated by antecedent precipitation, the maximum floods of record occurred on practically all major streams in the Muskingum River Basin, and the main stream rose to unprecedented heights. The record flow at the Tippecanoe gage has been estimated at about 9,000 cfs. The March 1913 flood caused the loss of 367 lives and damages amounting to \$14.0 million (1913 dollars) in the Muskingum River Basin. The high water profile of this flood along Brushy Fork is shown on **Plate No. 4-1**.

c. Storm and Flood of August 1935. The storm and flood of 6-7 August 1935 was one of the largest general summer floods to affect the Muskingum River Basin. A series of storms from 31 July to 4 August raised basin streams and decreased soil retention capacity. This created high runoff volumes occurring during the intensive rains of 6 and 7 August. An average of 4.1 inches of rain fell over the entire Muskingum River Basin in a period of 12 hours, with nearly every point in the basin receiving at least 2 inches. More than 8 inches of rain fell over a 400-square-mile area in the central portion of the basin, with more than 12 inches of rain being recorded near Newcomerstown. This storm produced record summer flows on the Tuscarawas River below Dover Dam, with a crest of 7,650 cfs at the Uhrichsville gage. The high water profile of this flood is also shown on **Plate No. 4-1**.

d. Storm and Flood of January 1937. A series of abnormally heavy rains in late December 1936 and most of January 1937 caused a major series of floods in the middle and lower portions of the Ohio River Valley. Tributary streams in the Tuscarawas River Basin experienced successions of flood rises which moved out of the smaller rivers to accumulate in the larger rivers resulting in increasingly higher stages and discharges after each storm. The heavy general rainfall continued off and on for nearly a month and concluded with the heaviest storm from 14 to 25 January in which 7.93 inches fell over the Muskingum River Basin. The partially completed flood control reservoirs helped decrease the peak stages and discharges by acting as retarding basins. A high water profile for this flood is shown on **Plate No. 4-1**.

e. Storm and Flood of January 1959. The storm and flood of January 1959 is generally regarded as one of the highest of record throughout most sections of the Tuscarawas River Basin. The conditions prior to the generalized rains on 20 and 21 January contributed greatly to the flood stages throughout the basin. Severe cold weather during December 1958 had frozen the ground to depths ranging from 6 to 18 inches. In addition a storm occurring between 14 and 17 January deposited from 0.50 to 1.84 inches of precipitation over the basin. The ground was thus saturated, frozen and covered with approximately 5-6 inches of snow, all of which greatly contributed to the high percentage

of runoff encountered after the generalized rain began. Most of the flood producing rains fell between midnight on 20 January and noon on 21 January. Based on an isohyetal map of the storm, approximately 1.5 inches of rain fell over the Clendening Lake Basin.

f. Storm and Flood of July 1969. On the evening of 4 July 1969, severe thunderstorms with intense rainfall moved across northern Ohio. The storm centered along a line beginning just east of Toledo and extended through Ashland and Wooster to Uhrichsville. The average rainfall over the Muskingum River Basin upstream of Coshocton for the 18-hour period ending at 1:30 pm 5 July was 6.6 inches. Unofficial measurements ranged from 10-14 inches for the same period in the Wooster area. Rainfall at Clendening Lake for the storm was approximately 4.55 inches. At Cadiz, just east of the basin's headwaters, rainfall was approximately 2.5 inches. The intense rainfall and runoff resulted in the rapid and severe inundation of much of the upper Muskingum River Basin, but the Clendening Lake Basin was not significantly affected by the storm. It is estimated that operation of the flood control structures in the Stillwater Creek Basin reduced flood stages at Tippecanoe and Uhrichsville by less than 2 feet.

g. Storm and Flood of February 1979. Antecedent conditions prior to moderate rainfalls near the end of February 1979 were mainly responsible for flooding conditions in the basin. Soils were frozen and a snow cover persisted over most of the Muskingum River Basin from early January to the onset of the major rainfall on 25-26 February. Snow cover on the basin ranged from approximately 6 inches in the northern part of the basin to 20 inches at McConnelville. Based on available data from Dover Dam and Senecaville Lake, snow cover on the Clendening Lake Basin was estimated to be approximately 16 inches. Temperatures rose to above freezing for the first time in nearly 4 weeks on 20 February and combined with rainfalls of less than 0.5 inch on 21-22 February, created rapid melting of snow and rising stages on the basin's streams.

Continued thawing combined with heavier rainfalls of approximately 1.5 inches over the basin on 25-26 February produced heavy runoff and considerable flooding in the Muskingum River Basin. Rainfall for this period was 1.75 inches at Clendening Lake and 1.43 inches at Cadiz. The basin reservoirs were utilized efficiently to reduce downstream flows and stages.

h. Storm and Flood of August 1980. Heavy rainfalls falling on saturated ground were mainly responsible for the flooding conditions experienced in many portions of the Muskingum River Basin in August 1980. The basin experienced average rainfalls approximately 150% of normal during June and July 1980. Widespread, intense thunderstorms produced the bulk of the basin's precipitation in August, with a large portion of the basin receiving more than 10 inches of rain during the month. Total monthly rainfall was 12.34 inches at Clendening Lake and 12.18 inches at Cadiz. Heavy rainfalls exceeding 1-2 inches were common throughout most of the Muskingum River Basin during storms of 2-6 August, 9-12 August, 17-19 August, and 21-22 August. Clendening Lake recorded 3.58 inches of rainfall during the storms of 2-6 August, 3.95 inches for the period 9-12 August, 2.76 inches for the period 17-18 August, and 0.69 inches for the period 21-22 August. This series of storms produced the pool of record at Clendening Lake, 909.0 feet NGVD. Operation of the Muskingum Basin dams reduced flood stages significantly during the month, especially downstream of Wills Creek Dam and Dillon Dam after the storm of 10-11 August.

4-07. RUNOFF CHARACTERISTICS

The Brushy Fork of Stillwater Creek watershed lies in an unglaciated section of the Appalachian Plateau and is characterized by rugged, hilly country with broad valleys which are conducive to a faster concentration of runoff. Basin runoff is highest during the winter months when storm rainfall may be augmented by snowmelt and when frozen or saturated ground can result in very low infiltration rates. Runoff is lowest during late summer and early fall, when the ground is dry and infiltration losses are high. **Table No. 4-3** below, presents average normal, maximum and minimum runoff from the watershed at the Uhrichsville gages, Ohio, based on 45 years of record at the USGS gage. The Uhrichsville gage is located at the Denison Water Supply Dam, and is regulated by Clendening Lake on Brushy Fork, Tappan Lake and Piedmont Lake on Stillwater Creek. **Table No. 4-3** below, shows the difference between the dry pre-construction summer flows and the regulated releases.

Month	Natural Flow 1922-1937		Modified Flow 1938-1960			
	Normal Average		Maximum Average		Minimum Average	
	Mod.	Nat.	Mod.	Nat.	Mod.	Nat.
January	572	837	1885	2917	60.9	30.6
February	680	712	1532	1280	34.6	64.8
March	828	864	1917	1718	357	227
April	784	638	1550	1128	125	188
May	560	450	1123	1215	172	37.3
June	325	272	784	829	59.7	9.25
July	204	186	627	701	11.0	4.64
August	159	194	424	1648	6.69	0
September	123	137	256	1023	4.99	0
October	118	148	407	705	5.43	0
November	291	339	771	1008	11.7	2.67
December	482	530	1202	1724	17.8	16.8
Annual	424	442	679	647	189	161

4-08. WATER QUALITY

Geological considerations are extremely important because rock and soil types in the basin determine, to a great extent, the chemical content of waters constituting the inflowing streams and, ultimately, the lake itself. The watershed lithology is predominately calcareous.

Land use patterns, including strip mining of coal and agriculture, also exert strong influences on the chemical characteristics of basin waters. For example, sulfate concentrations are relatively high, as are total salt concentrations and buffering capacity (alkalinity). Iron and manganese, possibly because of the calcareous nature of the basin and neutralization of acid drainage, are not present at problematic concentrations. Levels of nitrogen and phosphorus are high in the watershed, and phosphorus appears to be the biologically limiting

factor.

a. Chemical. In terms of major ions and descriptive parameters, inflow water to Clendening Lake is classified as a calcium-sulfate type. This represents an unbalanced condition. A normal condition is classified as a calcium-carbonate type. Water hardness in the basin is 830 mg/l Calcium Carbonate which is classified as very hard according to USGS classifications.

b. Impaired Waters. EPA requires the States to assign a designated use to all streams within the state. Those streams not meeting their designated use are listed as impaired waters. The Clendening Lake watershed is part of the Tuscarawas watershed where 53 streams, or 6 percent of the reported streams are listed as impaired. Potential sources of impairment are mining and pasture land.

Water quality data collected by the Corps of Engineers from 1983 to 2002 indicate that water quality in the basin reflects watershed conditions.

4-09. CHANNEL AND FLOODWAY CHARACTERISTICS

Brushy Fork Valley has a winding, flat bottom with rather steep walls that rise to a well dissected upland country whose total relief is approximately 300 feet. At the Clendening Lake damsite, the valley has a bottom width of 600 feet and a general elevation of 865 feet NGVD. The valley walls rise on moderately steep slopes to elevation 940 feet NGVD. Brushy Fork has a width of 30 feet, a water surface elevation of 859 feet NGVD and flows against the right, or southwest wall. Time of travel of Clendening Lake flood discharge along Stillwater Creek to Uhrichsville is approximately 30 hours, and to Newcomerstown on the Tuscarawas River is an additional 17 hours.

4-10. UPSTREAM STRUCTURES

There are no flood control structures upstream of Clendening Lake on Brushy Fork. Piedmont and Tappan Lakes are on adjacent forks of Stillwater Creek. Also, there are five more flood control lakes upstream of Stillwater Creek in the Tuscarawas River Basin. Bolivar and Dover Dams are dry flood control projects, while Atwood, Leesville, and Beach City Lakes are multi-purpose lakes.

4-11. DOWNSTREAM STRUCTURES

The only downstream projects below Clendening Lake on Stillwater Creek are Dillon Lake on Licking River, and Wills Creek and Senecaville Lakes in the Wills Creek Basin.

4-12. ECONOMIC DATA

a. Population. The Brushy Fork drainage basin above Clendening Lake lies wholly within Harrison County. There are no population centers within the Brushy Fork Basin. In 1980 Harrison County had a

population of 18,152; this was reduced to 16,085 in 1990, and on down to 15,856 in 2000. Cadiz, located just east of the basin's headwaters is the county seat, with 4,058 people in 1980, reduced to 3,489 in 1990.

b. Industry and Agriculture. In Harrison County, the principal industries are related to stone, clay, and glass. Manufactured goods include paperboard boxes, drain tile, pottery and brick. Agricultural items include dairy products and cattle. Bituminous coal is mined in Harrison County.

Harrison County has a total land area of approximately 258,000 acres. Approximately 19.5% of this area is devoted to cropland, 25.6% to pasture, 24.2% to woodlands, 28.5% to other farm land and farm facilities, and 2.2% to urban, built-up and other non-farm uses. The total land and water area within the Clendening Lake Recreational Area is approximately 6,550 acres, or approximately 2.5% of the county area.

c. Flood Damages. Areas subject to flooding downstream of Clendening Lake along Brushy Fork and Stillwater Creek consist of small farms, rural residences, and the communities of Tippecanoe, Uhrichsville, and Dennison.

Since their construction in the 1930's, the 14 original dams in the Muskingum River Basin reservoir system have continued to significantly reduce flood damages in the basin. Based on estimates of flood damages for both the natural condition and as modified by the reservoir system, the 14 original dams have helped prevent an estimated \$2.07 Billion dollars in accumulated total flood damages from 1936 through FY-98 or 30 September 1998.

Studies have been undertaken in the past to determine the relative percentage of flooding benefits afforded by each of the 14 Muskingum River Basin projects. These studies analyzed the contribution of each project for a number of selected Muskingum and Ohio River floods. Based on these studies, it was determined that the Clendening Lake project on its own was responsible for approximately 2.1% of the total Ohio River benefits afforded by the 14 Muskingum River Basin projects. Using the above total damage figure of \$2.07 Billion dollars, this would be a total of about \$44 million benefit dollars credited to Clendening Lake.

SECTION V - DATA COLLECTION AND COMMUNICATION NETWORKS

5-01. HYDROMETEOROLOGICAL STATIONS

a. Streamflow Stations. Several stream gaging stations, designed for the collection of hydrologic data, are located at strategic sites in and around the Brushy Fork - Stillwater Creek Basin. Those stations pertinent to Clendening Lake are shown in **Table No. 5-1**, Table Section.

(1) Stream Cooperative Program. The Corps of Engineers participates in the U.S. Geological Survey Federal-State Cooperative Water Resources Program under which the Survey installs, rates and maintains the gages at locations desired by the cooperating entity, except at Corps' projects where the lake and outflow gages are originally installed by the Corps. Under this program, the Survey maintains stream gaging stations on Stillwater Creek at Piedmont, Tippecanoe, and Uhrichsville, Ohio, and on Little Stillwater Creek below Tappan Lake.

The Corps of Engineers also maintains several gages in the Muskingum River Basin independent of the stream cooperative program. Those pertinent to Clendening Lake include the lake gages at Piedmont, Tappan and Clendening Lakes.

(2) Collecting and Reporting Facilities. Strip chart recorders provide a graphical record of stream stage and a backup for Analog-to-Digital Recorder (ADR) devices. Shaft encoders are now being used to digitally record water levels. The data collection platforms mentioned earlier in sub-section 5-01 have been installed at basin gages as listed in **Table No. 5-1**, Table Section. The platforms store stage and precipitation data and every four hours transmit to the LRD computer downlink via the Geostationary Operational and Environmental Satellite. The Water Management Section's water control system receives data automatically from the LRD water control system on an hourly basis. If desired, the District can also access the data at other times by operator control.

Some data collection platforms have the capability of reporting in response to a telephone query by computer, terminal or human. The query can be initiated at any time from the water control system, Project Office or the home of a selected individual during off-duty hours. In response to a human caller, the platform will respond with the last recorded information such as stage with a synthesized voice. Information from the DCPs may also be obtained directly by the water control system computer. The DCP's can also dump several readings taken over a period of hours to a computer terminal. These DCPs have been installed at critical locations such as inflow, lake, outflow, and some control point stations.

(3) Reports. Currently, morning reports from the Muskingum River Basin projects, containing stage, precipitation, operational and temperature data, are received in the Water Management Section as computer printouts from the water control system. They are received in the same format in which they are input at the Muskingum Area Office. Stage data are converted to flow and the values are used in the forecasting process. Frequency of reporting, and thus data collection, are dependent on the degree of urgency of weather and/or flooding conditions.

The frequency ranges from daily (5 days per week) at about 0730 hours

under Normal Conditions to hourly under Major Flood Conditions when the lake level approaches or threatens spillway elevation. Project data are submitted to the District (WCS) water control system in accordance with the Schedule for Reading Gages, **Plate 3-1** of Instructions to Dametnder. All satellite data are disseminated automatically by the LRD water control system to the District on an hourly basis.

b. Precipitation Stations. The Ohio River Reporting Network, a division-wide cooperative program with the National Weather Service, involves interchanges of information between the Weather Service and the Corps of Engineers which utilizes the respective installations and experience of the two agencies. The Weather Service recruits, trains, equips, and pays observers at Corps requested locations and receives and records data from them. The Weather Service also provides weather and stream stage data, Ohio River and tributary forecasts, regular and requested special forecasts, radar and other special reports on request.

(1) In addition to reimbursing NWS for direct costs incurred on the Corps' behalf, Huntington District provides NWS with all precipitation, snow cover, and stage information received in the Water Management Section from reservoir and other reports, three-day pool and outflow forecasts, and depth reports from the Corps of Engineers' Snow Cover Reconnaissance.

Precipitation stations in and near the Clendening Lake watershed include Tappan Lake, Cadiz, Clendening Lake, and Piedmont Lake.

(2) Collecting and Reporting Facilities. Normal equipment is the 8-inch Standard Rain Gage with a metal support. All the above named stations have this standard gage except Piedmont Lake which uses a tipping bucket gage. At ORN weather stations the measuring instrument, the standard 8-inch rain gage, is read and reported manually by telephone landline to the Muskingum Area Office. At the unattended station, the "tipping bucket" measuring gage is interfaced to a data collection platform. The platform receives the signal electrically and transmits to the computer downlink via the satellite. Station locations are shown on the Basin Drainage Map, **Plate No. 2-1**, and data collection and communication equipment at each are listed in **Table No. 5-2**, Table Section.

(3) Reports. Project personnel at Clendening Lake, Piedmont Lake, and Tappan Lake, report by telephone to the Muskingum Area Office. The Muskingum Area Office in turn transmits the data to the District water control system.

The Water Management Section utilizes platform information, morning report information and Weather Service data in forecasting and computing average precipitation over the Clendening Lake Basin and Muskingum River Basin District. Weather Service information for areas lacking Corps projects, when plotted on the District Isohyetal Map, provides better understanding of storm movement and aerial intensity. This additional coverage contributes to improved water management decisions.

National Weather Service radar also provides valuable information for regulation and forecasting. Radar receivers at NWS display reflected

"echoes" of precipitation in the form of a visual readout. These radar echoes show relative intensity and aerial extent of the precipitation. The NWS Hydrologist analyzes the radar information for position, direction and speed of movement, and estimated precipitation amounts and relays this analysis by telephone on request.

A large portion of the total precipitation information received by NWS comes through the cooperative ORN program. Complete district morning report data accessed from the Water Management Section mini-computer (water control system) are reorganized by NWS personnel into downstream format and inserted into the NWS Eastern data bank. The data are widely used by NWS elements such as those producing infiltration indices and short, medium and long-range forecasts, and by the River Forecast Center in Cincinnati which produces Ohio River and tributary stage and flow forecasts. The Cleveland office utilizes the data early in their mid-morning weather report including any updating of the forecast which may be indicated.

5-02. WATER QUALITY STATIONS

The original design and construction of the Muskingum projects was completed many years before any considerations for water quality were developed. The outlets works at the Muskingum projects were not designed with maintenance or improvement of water quality as one of their purposes, therefore the quality of release waters could not be regulated. Samples were collected on an as-needed basis.

a. Facilities. Many years later water quality networks were established at each Muskingum Lake. Stations were established on major inflows for assessing baseline conditions and long-term changes. Outflow stations were established immediately below each project to evaluate the quality of reservoir releases and to assess long-term changes. Sampling stations on the reservoirs were located at the deepest point of transect, in the old stream channel. The main lake station near the dam was used as the primary location for collecting chemical and other selected data including the assessment of lake stratification and possible density layers. Accordingly, a primary network of thirteen water-quality-sampling stations was established at Clendenning Lake. The diagram and location of the network stations are shown in **Plate No. 5-3**, and all water quality stations are described on the next page in **Table No. 5-3**, next page.

Present sampling programs are oriented toward existing or potential effects and are structured to describe various factors that affect water quality. The chemical composition of water may be defined by grouping the substances that compose the dissolved solids. Relationships among these groups of chemicals determine the type of water.

The geology of each reservoir basin determines the chemical composition of the major dissolved salts. Basins are classified on the basis of calcium and magnesium concentrations. In humid areas where evaporation is low, the waters are composed of dissolved salts from the rocks and soils in the basin. These waters are usually classified as calcium carbonate. In dry areas, where evaporation is high, calcium carbonate is precipitated out leaving the dominant dissolved salt, sodium chloride. If the basin has been thoroughly leached, then the supply of dissolved salts will be low and their chemical composition will be determined by precipitation in the basin.

TABLE NO. 5-3

Description by Location of Clendening Lake
 Primary Water Quality Sampling Stations

<u>STATION</u>	<u>Distance from the Dam</u>
1CLB0001	0.5 miles below
1CLB0002	700 feet above
1CLB0003	10 miles above
1CLB0004	0.2 miles below
1CLB0005	21 miles above
1CLB0006	9.6 miles above
1CLB0007	7.0 miles above
1CLB0008	3.8 miles above
1CLB0009	6.8 miles above
1CLB0010	0.4 miles below
1CLB0011	0.2 miles below
1CLB0012	2.3 miles above
1CLB0013	5.4 miles above

During early 1986 a cooperative agreement was reached with the Muskingum Watershed Conservancy District (MWCD) for joint field efforts with MWCD to be initiated in the spring of 1986. Primary advantages of the joint effort include optimizing personnel and equipment use, eliminating duplication of effort, providing a larger pool of knowledge and expertise, and increasing the probabilities of adequately addressing problems. The objectives of the water quality sampling program include establishing a base-line condition to monitor subsequent changes, identifying water quality environmental problems, and providing adequate data for facilitation coordination with other agencies in regard to implementing any needed watershed pollution control. Other parameters which are listed in **Table No. 5-4**, next page, are collected monthly April through September once every 10 years. Once every five years, the Water Quality team utilizes one day to sampling the parameters listed in **Table No. 5-4**, next page. A detailed description of the Water Quality Program for Clendening Lake is presented in Section VII, Water Control Plan.

- a. Reporting. Water quality data collected at Clendening Lake is used to meet such objectives as:
- (1) Establish baseline conditions and monitor subsequent changes.
 - (2) Identify water quality environmental problems.
 - (3) Study special problems or develop criteria for such solutions as modification of reservoir regulation procedures aimed at controlling or enhancing environmental conditions and meeting water quality objectives.
 - (4) Provide a database adequate for understanding project conditions and for coordination with state agencies in regard to implementing any needed watershed pollution control.

collection-stations are determined by specific project conditions. The water quality program design for Clendening Lake was structured to describe various factors affecting water quality over the long term.

Data collected are used for applications such as identification of trends indicating problem conditions and reporting existing conditions.

Basic studies consist of 5 essential components:

- (1) In-situ measurements to evaluate distribution of various properties
- (2) Wet chemistry and various types of solids for both immediate and long-term use
- (3) Indirect but rapidly obtainable indicators of productivity such as chlorophyll and carbon
- (4) Benthic organisms to monitor long-term quality of streams
- (5) Other biological measurements such as plankton and seston

Standard physical/chemical tests and reasons for testing are presented below in **Table No. 5-4**, below.

Table No. 5-4	
Standard Physical/Chemical Tests	
<u>Type of Test</u>	<u>Reason for Testing</u>
Calcium (Ca)	Major Cations - Ionic Balance, ratios and relationships
Magnesium (Mg)	
Sodium (Na)	
Potassium (K)	
Sulfate (SO ₄)	
Chloride (Cl)	Major Anions - Ionic Balance, ratios and relationships
Nitrogen (N)	Nutrient
Nitrate + Nitrite	
Ammonia	
Total Kjeldahl	
Total Organic Carbon (TOC)	Nutrient
Phosphorous (P)	Nutrient
Total Filterable	
Solids	Equivalent Ambient Values, Correlation with optical measurements
Total	
Suspended Dissolved	
Hardness	Evaluate buffer capacity and Alkalinity characteristics
Metals	Important for hypolimnetic and outflow evaluations during stratification
Iron (Fe)	
Manganese (Mn)	
Dissolved Oxygen	<u>in situ</u> parameters used to evaluate conditions for project operation
Temperature	
pH	
Specific Conductance	

5-03. SEDIMENT STATIONS

a. Lake. Reconnaissance-scope sedimentation surveys were completed in 1939 and 1983 at Clendening Lake. In the 1939 study, profiles across the lake at eight locations were investigated but not referenced for future use. The area investigated represented only a small portion of the total conservation pool area. In the 1983 study, lake bottom profiles were obtained at 12 locations within the conservation pool area.

At the time of the 1939 survey, conservation pool levels had not been attained and the pool had not been above elevation 865 feet NGVD. It was assumed that all sediment was deposited below this elevation. A relatively low rate of sedimentation, 0.089 acre-foot per year per square mile of contributing drainage area was estimated from this reconnaissance.

For the 1983 study, water depth was determined by fathometer, and horizontal control was not maintained. A profile of minimum lake bottom elevations at each location is presented in **Plate No. 5-2**. A comparison was made of the 1983 reconnaissance profiles with original profiles scaled from original property mapping. This comparison indicated that sedimentation in Clendening Lake was not excessive or cause for alarm. Since sedimentation in the conservation pool at Clendening Lake was not considered to be detrimental to project purposes at that time, it was recommended that the next sedimentation survey be of reconnaissance scope, and be conducted in FY 1988. Due to lack of funds and other priorities, this survey was never completed.

b. Stream. Sedimentation in Brushy Fork within the area inundated by the conservation pool was analyzed as part of the 1983 sedimentation reconnaissance study.

5-04. RECORDING HYDROLOGIC DATA

The morning report will be compiled on ORH Form 14. This report will then be forwarded to the Area Office and to the Water Management Section. The Area Office then forwards a combined morning report by the District INTRANET System to the Huntington District Office, and a copy of the morning report is retained as a part of the permanent file at the project.

5-05. COMMUNICATION NETWORK

Communications between Clendening Lake, the Muskingum Area Office, the District Office, etc, is accomplished primarily by telephone. High quality Cell Phones are now installed at the District Office, area offices, construction field offices, and navigation lock and dam installations. Data collection DCP's are installed at several stream gaging stations and precipitation stations in the Muskingum River Basin. The DCPs transmit data (several readings over a period of hours) via the Geostationary Operational Environmental Satellite (GOES) to a computer downlink that is accessed by the Water Management Section. **Table No. 5-1**, Table Section, shows that voice DCP's have been added to some streamgaging stations. Operation of the DCP-satellite network is discussed in more detail in sub-sections 5-01 and 5-02. **Plate No. 5-4**, plate section, illustrates the communications network.

5-06. COMMUNICATION WITH PROJECTS

Telephone is the primary mode for most communication between the Water

Management Section and the multipurpose projects and area offices and between projects and respective area offices. Lines of communication for the Muskingum River Basin are illustrated in **Plate No. 5-4**, plate section. Cell Phones are now used for secondary backup communication, while mobile radio, State Police, courier, etc. is utilized during an emergency when a telephone or Cell Phone is not operational. Inter-project communication is mostly by Cell Phone with some telephone for privacy. Water Management Section personnel use the telephone to request and receive additional operations information and weather information and to give operational guidance and directives. The U.S. Postal Service is utilized for letter reports from projects to the Water Management Section, other voluminous or detailed information, pictorial material, confirmation of Special Directives, and any other formal communication between the Water Management Section and the projects. Occasional visits to the projects afford an opportunity for office and project personnel to discuss ideas, problems, new procedures, etc.

5-07. Warnings

There are no interests downstream from the dam vulnerable to flooding at discharge rates up through respective channel capacities. However, in order to advise recreators below the dam of impending increases in outflow, a discharge warning horn is blown at the pylon whenever the total gate opening is to be increased. Clendening Lake Water level Warnings, **Table No. 5-5**, next page, list various pool and location of impact levels during high water situations at the lake.

Clendening Lake personnel coordinate in person and by telephone with Ohio Division of Natural Resources personnel concerning the forest fire protection agreement with the Forestry Division. Project personnel cooperate with the Environmental Health Services Department by sampling all drinking water for biological safety factors, mailing to Columbus for analysis and receiving results by mail. In addition, a copy of the monthly water plant report on chemicals and water use is submitted for informational purposes.

County offices with which project personnel communicate are the Sheriff's and Health Departments, the first in conjunction with the patrol and law enforcement contract, and the second concerning periodic inspections of the Marina in compliance with provisions of the Corps of Engineers lease.

**TABLE NO. 5-5
 CLENDENING LAKE - WATER LEVEL WARNINGS**

<u>Site</u>	<u>Elev/Criteria</u>	<u>Party Warned</u>	<u>Manner Issued</u>	<u>Action Taken</u>
County Rd 6 Boat & Marina Ramps	889.0 dropping	Users	In-person	Clear area and secure barricade
Winter Pool	893.0	Users	Posted	Clear Area
Marina	896.5 dropping	Concession Operators	In-person	Clear area and secure barricade
Summer Pool	898.0	Users	Posted	Clear Area
State Rt. 799	899.0 rising	Users	Posted Highway Dept. for Barricades	Notify State
Marina & Boat Ramp	904.0 rising	Operators	In-person	Clear area and secure barricade
County Rd 6 Boat Ramp	906.0 rising	Operators	In-person	Clear area and secure barricade
Alert Pool	907.0	Users	Posted	Clear Area
Harrison County Roads, 1 and 21	910.0 rising	Users	Posted	Clear Area
Township Roads 304, 311, 312, 338, 339, 340	910.0 rising	Users	Posted	Clear area and secure barricades
Flood Control Pool	910.5	Users	Posted	Clear Area

The Damtender determines whether to clear other areas, or clear and barricade them sequentially as the water rises.

SECTION VI - HYDROLOGIC FORECASTS

6-01. GENERAL

Hydrologic forecasts of lake elevations and stream flows in the Stillwater Creek Basin are vitally important for Water Control Management as these forecasts provide information, which enable the optimal regulation of the projects. The Water Management Section uses all available hydrologic and meteorologic data in forecasting efforts for the Stillwater Creek - Tuscarawas - Muskingum River Basin. These forecasts are conducted under low-flow, normal flow, and flood conditions and are primarily developed by the Corps of Engineers and the National Weather Service on a daily basis.

a. Role of Corps.

(1) District Office. In accordance with ORDR 1110-2-27, dated 12 January 1976, Subject: Water Control Management Activities, the Water Management Section performs water control management activities for multi-purpose projects throughout the Huntington District. These activities include the preparation of forecasts for lake inflows, lake levels, project outflows, water quality, outflow temperature, and flows at downstream stations to ensure the safe and efficient operation of the district projects. River forecasts prepared by the Corps of Engineers are generally used for its own responsibilities and are not normally issued to the general public unless the National Weather Service is willing to make the release or agrees to such a release.

(2) Division Office. The Water Management Branch at the Great Lakes and Ohio River Division Office (LRD) utilizes the 5-day tributary forecasts prepared by the individual districts to derive its own 5-day flow forecasts for stations along the Ohio River.

b. National Weather Service. The National Weather Service (NWS) has the official responsibility for preparing forecasts of Ohio River stages, tributaries and flows and for transmitting data, forecasts, watches, and warnings to users and the general public. NWS also collects and evaluates weather data from a variety of sources to prepare short and long-term weather forecasts.

6-02. FLOOD CONDITION FORECASTS

a. Requirements. Whenever "flood threat" conditions approach, as defined by the Schedule for Reading Gages, forecasting effort primarily focuses on area rainfall, downstream flood control points, and the lake elevation. The basin forecast is computed using one-hour data and it normally takes one hour to complete the forecast of the Muskingum River Basin. The model is executed repeatedly during the flood event as additional data becomes available.

The forecast data is used to predict the anticipated pool crest, downstream flood crests, necessary storage releases, and probable duration of flood period. The reservoir storage data used in the forecast model program is summarized in **Table No. 6-1**, below.

The control stages and flows for the Tuscarawas River Basin are summarized in **Table No. 6-2**, below. The detailed drainage areas for the Tuscarawas - Muskingum River Basin are listed in **Table No. 6-3**, page 6-4, and are shown on **Plate No. 6-1**.

Pool	NGVD Surface Elevation	Backwater		Storage		runoff	
		Area Acres	Stream Miles	Net	Gross	Net	Gross
Winter	893	950	6.8	8,400	8,400	2.3	2.3
Summer	898	1,800	12.5	18,100	26,500	4.9	7.2
Flood Control:							
Winter	910.5	2,620	14.1	45,600	54,000	12.4	14.7
Summer	910.5	2,620	14.1	27,500	54,000	7.5	14.7

TOTAL	910.5	2,620	14.1	54,000		14.7	

b. Methods. In order to achieve the most efficient water control management possible, a real-time computer model, developed for Water Management Section by the Hydrologic Engineering Center (HEC), Davis, California, was adapted and calibrated for use in water management of the Tuscarawas River Basin. The basin computer model is the major part of the District water control system, uses real time data from the Corps of Engineers satellite-platform network in and adjacent to the basin, in conjunction with the tables used to interpret this data. The modeling process includes reviewing and editing of all data, estimation of future flows, development and review of multiple lake outflow plans, and determining the optimal method of operation to decrease downstream flooding while still insuring the projects viability.

Station	Stream	Summer		Winter		Travel Hours
		Stage	Flow	Stage	Flow	
Clendening Dam	*Brushy Fork	No Directive	270		270	0
Clendening Dam	Brushy Fork	With Directive	540		540	0
Tippecanoe	Stillwater Creek	10.5	1,140	12.0	1,400	0.5
Uhrichsville	Stillwater Creek	3.5	2,203	5.0	*3,090	10.4
Dresden	Muskingum River	**16.0	23,450	18.5	32,000	41
Zanesville	*Muskingum River	19.5	38,200	21.5	48,000	45
McConnellsville	Muskingum River	10.0	35,600	11.0	41,600	51
Marietta	Ohio River		35.0		35.0	72

*Normal flooding use 4.0 an 2,526 cfs.
**DEMIA is December to mid-April; MIANO is from mid-April to November.

A typical sequence of modeling events leading to water control management decisions is described as follows:

1. Satellite data, both stage and precipitation, are received from the LRD downlink, decoded and added to the resident database. This is done automatically each hour.

2. Observed precipitation and stage data are reviewed graphically to insure integrity. Any necessary corrections are made and any missing data are added when available from supplementary sources.

3. The precipitation-runoff model is executed based on observed data up to the time of forecast. If precipitation is occurring at the time of forecast then future precipitation is considered in the model execution at the request of Division.

4. The small basin hydrograph forecasts are then reviewed and modified if necessary. The second part of the model is then executed to route, blend and combine flows. The flows are reviewed, the lake outflows modified if necessary, and the second part of the model is recomputed.

5. Step 3 is repeated to obtain subsequent forecasts that consider any additional precipitation (QPF), special regulation or other hypothetical analyses that may be required.

The real time modeling program makes extensive use of small-area unit hydrographs, infiltration rates, discharge rating tables, routing coefficients, and graphical review of flood hydrographs and profiles. The computer program assimilates the total precipitation over a 3-day time period and analyzes the storm in detail. By using predetermined basin rainfall infiltration rates and runoff percentages the program computes the antecedent rainfall, base flow, and storm runoff.

By applying the computed storm runoff to the appropriate unit-hydrographs a computed hydrograph is developed. The computer then uses routing coefficients with routing and combining methods to route the flood downstream and through Clendening Lake. With this computer program and practical experience the Water Management Section is able to produce a reliable forecast for the Tuscarawas River Basin.

Table No. 6-3, next page, is an example of the various small areas above and below Clendening Dam which small-area unit hydrographs are developed. **Plate No. 6-1** shows the basic forecast areas for the Stillwater Creek, while **Plate No. 6-2** shows the Tuscarawas River network configuration.

TABLE NO. 6-3

**DRAINAGE AREAS AND STREAM FLOWS OF
TUSCARAWAS RIVER AND PRINCIPAL TRIBUTARIES**

Location	Miles Above Mouth	Drainage Area (sq.mi.)	Period of Record	Maximum Flow CFS	Minimum Flow CFS	Mean Flow CFS
Tuscarawas R. At Massilon	86	518	1937-pres	10,700	49	456
Sandy Creek At Waynesburg		253	1937-pres	15,000	6.9	270
Conotton Creek At mouth	-	286.3				
Tuscarawas R. Below Dover Dam	60.3	1405	1923-pres	62,000	68	1,430
Sugar Creek At mouth		356.2	1938-pres	6,930	1.0	939
L. Stillwater C. at Tappan Lake		71.1	1938-pres	1,050	0	77
Brushy Fork At Clendening Lake		69	1938-pres			
Stillwater Creek At Piedmont Lake		122	1938-pres	1,470	0.2	137
Stillwater Creek At Tippecanoe		282	1938-pres	4,410	1.1	320
Stillwater Creek At Uhrichsville		367	1922-pres	7,650	0	430
Stillwater Creek At mouth		485.1				
Tuscarawas R. At Newcomerstown	21.3	2443.	1921-pres	83,000	170	2544
Tuscarawas R At mouth at Coshocton	zero	2590.				

The small area three-hour adopted unit-hydrographs for the various Brushy Fork forecast areas are shown on **Table No. 6-4**, next page. The unit hydrograph data was derived for the 1975 Dodson-Lindbloom Muskingum Spillway adequacy study of 1975. The Discharge Rating Curve for the Clendening Lake spillway is shown in Section VII.

TABLE NO. 6-4

ADOPTED THREE-HOUR UNIT-HYDROGRAPHS FOR
PRINCIPAL POINTS FOR CLENDENING LAKE

Time Hours	Natural Unit Graph	Inflow Unit Graph	1-A Pool Head	#2 Around Pool	#3 Pool Area
3-hours	69.3	69.3	43.2	22.1	4.0__
.0	0	0	0	0	0
3	140	210	130	65	425
6	330	570	310	175	425
9	625	1100	630	355	
12	1150	1700	1200	615	
15	1555	2000	1400	790	
18	1750	1790	1240	760	
21	1640	1520	1010	600	
24	1450	1275	765	415	
27	1240	1060	570	290	
30	1015	790	410	205	
33	795	560	310	145	
36	610	440	250	100	
39	475	380	200	70	
42	375	305	170	50	
45	300	260	140	30	
48	250	220	115	20	
51	210	180	95	10	
54	180	155	80	5	
57	150	135	70	2	
60	130	110	60	0	
63	110	90	50		
66	95	75	40		
69	80	60	30		
72	65	45	25		
75	55	40	20		
78	45	35	15		
81	35	30	11		
84	25	25	8		
87	20	20	4		
90	15	15	2		
93	10	10	1		
96	5	0	0		
99	2				

River and lake forecasting is accomplished with data stored and processed through the Ohio River Reporting Network. This network is a division-wide cooperative program with the National Weather Service, which involves interchanges of information between the Weather Service and the Corps of Engineers that utilize the respective installations and experience of the two agencies. All weather stations in the Muskingum River Basin are automated DCP stations. The Weather Service also provides weather and stream stage data, Ohio River and tributary

forecasts, regular and requested special forecasts, radar and other special reports on request. In addition to reimbursing NWS for direct costs on Corps behalf, the Huntington District provides NWS with all precipitation, snow cover, and stage information received in the Water Management Section from reservoir reports. Also included are three-day pool and outflow forecasts, and depth reports from the Clendening Lake project areas. The extent and intensity of the ORN program is shown by the fact that in addition to the project morning report data, all data received by NWS in the Tuscarawas River Basin are from Corps financed satellite stations.

The data collection platforms mentioned above store stage and precipitation data and, every four hours, transmit to the LRD computer downlink via the GOES satellite. The Water Management Section's Control System receives data automatically from the LRD water control system on an hourly basis. All the data entered into the Water Management System is stored in a database and used by water control software programs, allowing more timely and efficient water management decisions and generation of required reports.

While primary dependence is on morning report information, Water Management Section personnel use Weather Service data, available between 0900 and 0930 hours, in forecasting and computing average precipitation over the basin, area, and District. The data is used to fill in, by implication, for missing data and for confirmation or refutation of doubtful readings. Weather Service coverage of areas lacking Corps projects, when plotted on the District Isohyetal Map, provides basis for better understanding of storm movement and areal intensity, which contributes to improved water management decisions. Radar images on the NWS screen at Jackson, Kentucky, and Wilmington, Ohio, provide valuable information for regulation and forecasting. The NWS Hydrologist analyzes for position, direction, speed and estimated precipitation amounts in storms and relays this analysis by telephone on request. Ohio River and tributary stage and forecasts provided by the NWS are used to answer telephone calls from the public and particularly from local barging concerns. Data from NWS is received by the water control system via network connection. Project data is also disseminated back to NWS by the water control system.

6-03. CONSERVATION PURPOSE FORECASTS

a. Requirements. Conservation forecasts are executed in conjunction with the flood control forecast. They are executed on a daily basis for the next five days and on a weekly basis for the next 30 days. The main focus of the conservation forecast is to maintain seasonal pool at Clendening Lake in order to provide fish and wildlife habitat, recreation, and water supply. At the present time, operations for water temperature and quality are based on observations rather than forecast.

b. Methods. The methods and procedures for nonflood streamflow projection are the same as mentioned previously for the flood forecasting except the concern of the modeler is the low-flow analysis. The repetitive process is utilized to operate the reservoir in order to provide downstream low-flow requirements and then to evaluate their impact on the lake pool.

6-04. LONG-RANGE FORECASTS

a. Requirements. Long-range forecasts assist the Huntington District and the Great Lakes and Ohio River Division in water control management in the Tuscarawas River Basin. Long-range forecast of a dry spring can allow earlier than normal filling during late winter or early spring to reach summer conservation pool levels in time for the beginning of the recreational season. If a drought is projected, conservation pool may be raised to store additional water for later release downstream. Long-range forecasts are required by the Division Headquarters Water Management Branch (WMB) as they utilize it to inform the Mississippi Valley Division (MVD) of probable future conditions and to suggest specific items of water control management to the districts.

b. Methods. The Water Management Section produces a weekly forecast for the next 30-days utilizing the same method as used for flood forecast. This forecast assumes no future rain. Lower than normal precipitation forecast are produced by the National Weather Service.

6-05. DROUGHT FORECASTS

a. Requirements. The Huntington District now uses the drought forecast of the National Weather Service. The Corps summer drought forecast was discontinued in lieu of the regular NWS forecast.

b. Methods. The long range and conservation forecast address all forecasting concerns that would be raised by a drought. No extra forecast activities are planned for this time.

c. Reference Documents. Many of the basic documents for drought forecast are in Water Management Section files for the Huntington District, Huntington, West Virginia. These files contain records prepared by the Ohio Department of Natural Resources and the Ohio USGS for past drought periods, Water Availability Studies for the Muskingum River Basin, and the Ohio River Basin Comprehensive Study, prepared by the Great Lakes and Ohio River Division, Cincinnati, Ohio. The national and state weekly drought forecasts are included with the Palmer Index summaries for the current and preceding drought periods. During a drought period the low-flow records and reference books are used to prepare a weekly drought information bulletin for distribution to all concerned groups.

6-06. NORMAL CONDITION FORECASTS

a. Requirements. Normal conditions, as defined by the Schedule for Reading Gages, Exhibit B, covers all hydrologic conditions from drought to the beginning of high water conditions labeled "Flood Threat." The various conditions are based on the quantity of water a project is required to handle in comparison with design quantities. Other forecasts that are used for management of the Tuscarawas River Basin include water quality and outflow temperature. The Water Control Center in the Great Lakes and Ohio River Division Office requires daily 3-day pool-and-outflow forecasts and a 5-day forecast of tributary inflows to the Ohio River in order to implement its 5-day forecast of flow in the Ohio River and into the Mississippi River.

b. Methods. The forecast procedures described in paragraph 6-04 are used to produce forecasts for normal ranges of flows. A basin forecaster, assigned to the Tuscarawas - Muskingum River Basin, utilizes the Water Control System computer model each day and couples the results from the model with knowledge and experience with the basin to produce the required daily forecasts. The computerized forecast is then made available for distribution to interested parties and groups.

(1) Low-Flows - The procedures outlined in 6-04 are used in low-flow conditions. If forecasts indicate a continued low-flow condition leading to a drawdown of the lake level below seasonal pool, the Damtender is appraised of the condition. Marina operators and other affected parties are in turn notified of the changing situation by the Damtender.

(2) Water Quality - Routine water quality sampling has shown that concentrations of manganese and iron are present in the lower portions of Clendening Lake. These constituents are not harmful, but when released downstream under summer stratification conditions they can cause taste and odor problems. The results of chemical tests on water samples are not returned soon enough for emulation purposes; however, the concentration of manganese and iron are known to increase with the depletion of oxygen in the lower lake portions during stratification. Therefore, the weekly dissolved oxygen profiles taken during the summer months are used as a forecast of weekly conditions within the pool, and as an indicator of when releases should be adjusted for the Dennison Water Supply Plant.

(3) Temperature - Weekly temperature profiles are used as an indicator of weekly temperature conditions in the lake. If the trend of the outflow temperature appears to soon exceed allowable criteria, gate adjustments are made to offset the trend and remain within allowable temperature limits.

SECTION VII - WATER CONTROL PLAN

7-01. GENERAL OBJECTIVES

In accordance with ER 1110-2-240, "Water Control Management," and ORDR 1110-2-27, "Water Control Management Activities", the plan of water control management and regulation reflects optimal consideration of the primary project purpose of flood control. In developing the plan of regulation, the following general requirements were considered and evaluated in preparing an overall effective water control plan for the Clendening Lake Project:

1. Prevention or reduction of serious damages to the communities along Stillwater Creek.
2. Reduction of agricultural losses from minor floods on Brushy Fork and Stillwater Creek to the greatest extent consistent with the safe operation of the reservoir.
3. Through the use of siphons, maintenance of a summer recreation pool at or near elevation 898.0 feet NGVD for general conservation and recreational purposes, subject to flood control.
4. Maintenance of a minimum flow in Brushy Fork and Stillwater Creek to prevent stagnation in the stream immediately below the dam.
5. Maintenance of a designated minimum winter pool in accordance with an annual proposal by the Muskingum Watershed Conservancy District, normally at elevation 893.0 feet NGVD, for conservation, siltation reserve, flood control, and provision of minimum discharge.
6. Flood control in cooperation with Piedmont Lake and Tappan Lake for maximum control of flows along Stillwater Creek.

7-02. MAJOR CONSTRAINTS

Operation of Clendening Dam must be within the confines or constraints of the Tuscarawas - Muskingum River Basin Water Control plan. The various project purposes may at times strongly conflict; therefore priorities must be established and followed. Flood control is the primary project purpose, but this function can be inhibited by restrictions on the hourly rate of gate change, the lack of storage volume because of construction in the lake area, or the inability to discharge storage as quickly as planned because of floodplain encroachment or downstream construction. During the summer there is a recreation function with a recreation pool to be maintained, plus a continuous minimum flow for water supply, therefore, there is a concern for low inflow due to lack of upstream rainfall. Operational limitations concerning flood control functions are on **Table No. 7-1**, next page.

Most of the conflicting interests and purposes are resolved by practical planning and allocation of the lake storage volume into pools as listed on **Table No. 6-1**, page 6-2. The difference in storage volume at maximum flood control pool elevation, 910.5 feet NGVD, and the minimum winter pool at 893.0 feet NGVD is 35,500 acre feet, equivalent to 9.7 inches of run off from the drainage area. After proper study and authorization, this volume was all allocated for winter flood storage capacity. Accordingly, there is still a small minimum winter pool at Clendening Dam, which provides for sediment storage space and winter

habitat. During normal routine winter reservoir operations, the minimum continuous 1.5 cfs, plus any additional daily inflow is passed on through sluice gate No. 2.

TABLE NO. 7-1

MAJOR CONSTRAINTS FOR CLENDENING LAKE

Pool Level Elevation NGVD	-	Streambed	854.0	zero storage
Minimum Winter Pool Elevation	893.0,	18,500 ac-ft,	1,430	acres area
Minimum Summer Pool Elevation	898.0,	26,500 ac-ft,	1,800	acres area
Maximum Flood Control Pool	910.5,	54,000 ac-ft,	2,620	acres area
Maximum Reservoir Capacity	923.5,	94,000 ac-ft,	3,580	acres area
Top of Dam	925.5 feet	NGVD		
Gate Change Maximum Rate	-	0.5 feet per hour	on	Outflow gage
Sluiceway maximum flow	-	910.5 NGVD	Outflow	- 1,800 cfs
Design Flood Crest	-	923.5 NGVD	Outflow	- 17,000 cfs
Spillway maximum Flow	-	923.5 NGVD	Outflow	- 17,000 cfs
Minimum All year Outflow	-			1.5 cfs, @ "0" gage
Max. All year Outflow	<u>without a directive</u>	-	270 cfs,	@ "0" gage
Max. All year Outflow,	<u>BY SPECIAL DIRECTIVE</u>	-	540 cfs,	@ "0" gage

Constraints to regulation that are of special concern are those affecting fulfillment of the project purposes. Exercise of the flood control function can be inhibited by restrictions on storage of the design volume of water such as construction in the lake area and/or by inability to discharge storage as quickly as planned, because of floodplain encroachment. With Clendening Dam the principal problems encountered since regulation began were gradual building encroachment of the flood plain and occasional false gage reports from the outflow gage created by flash flooding below the dam.

Compliance with a requested deviation as outlined in subsection 7-06a may become a constraint to regulation if some assumed factor, such as weather, developed differently from the way assumed and the requested special regulation was substantially different than the regulation dictated by the changed conditions.

The normal Huntington District release rate for many years had been based on a maximum rate of change in stage of 0.50 foot per hour. In order to retard the post flood bank erosion the rate of change is very carefully monitored. This rate is used unless an emergency arises and the Water Management Section may issue Special Directives for a higher rate of stage change.

The gradual flood plain encroachment problem was created and compounded because the only time the maximum channel capacity was ever used was in a major flood, and sometimes not then. Therefore, the maximum channel capacity was gradually forgotten or dismissed, with the result that the residents along Stillwater Creek soon began to gradually build and move a little closer to the stream. Soon the new property was within the maximum channel limits and on occasions the property owners would complain about flooding in their basements.

The recommended solution is for each property owner; on or near the Stillwater Creek floodplain, install a shut-off valve in their

basement drain pipe. Furthermore, once a year, if possible, the maximum channel capacity should be used with a public warning to remind everyone of the location of the maximum channel capacity flood plain. Rising pool levels also affect recreation interests upstream. When the flood pool reaches elevation 903 feet NGVD at Clendening Lake, portions of the public campgrounds and concession areas are affected by high water. Also portions of State Route 799, County Roads 1 and 6, and Nottingham Township Roads 305, 330, 331 are inundated by the flood pool.

7-03. OVERALL WATER CONTROL PLAN

Clendening Lake is part of the flood control system of the entire Ohio River Basin as well as of the Stillwater Creek - Tuscarawas - Muskingum River Basin projects. Clendening Lake has no upstream tributary lakes that modify the inflow into the dam, but, there are two nearby reservoirs on tributaries of Stillwater Creek, therefore, operation of Clendening Dam requires close coordination among all the Tuscarawas - Muskingum River flood control projects. Coordination of the regulation is toward maintenance of rough equivalence of degree of utilization of flood control storage capacity between the projects to maximize the ability of the reservoir system to meet potential flood threats in the Tuscarawas and Muskingum River Basin and along the Ohio River below Marietta.

Flood damages occurring along Stillwater Creek and the Tuscarawas and Muskingum River to Marietta primarily involve residences, utilities, highways, and commercial; with lesser amounts to agriculture and extractive industries. The most valuable agricultural products are from livestock, which sustain only slight damage from flooding. Greatest flood damages in the past have occurred to residences in the communities of Tippecanoe, Dennison, Newcomerstown, Coshocton, Dresden, and Zanesville; as well as individual residences along the river and to small villages of less than 200 people. Clendening Dam drains 69 square miles and this constitutes 14.5 percent of the 485 square mile Stillwater Creek Basin. The optimal method of regulation coordinates operation on the basis of comparative storage utilization and, to the fullest extent possible, with regulation of flood control projects on other tributaries of the Ohio River.

As mentioned previously the Tuscarawas River joins the Walhonding River in the lower part of Coshocton, Ohio. The Coshocton USGS gage is about two miles below the forks of the Muskingum River and drains about 4,848 square miles; with about 3,435 square miles controlled by Dover and Mohawk, Beach City, and three small lakes in the Stillwater Creek basin, and a balance of uncontrolled area of about 1,413 square miles. This area is composed of Killbuck Creek, 613 square miles, 140 square miles on the lower Walhonding River, and a large uncontrolled area of about 660 square miles on the lower Tuscarawas River.

The record flood of March 1913 and the third highest flood of January 1959 were both created by a combination of very heavy rainfall and melting ice and snow. The flood of March 1913 had a record crest flow of about 202,000 cfs at the Coshocton USGS gage, and a record crest at the Tippecanoe Gage of about 9,000 cfs. This flood occurred before construction of the Muskingum River flood control system, but, the record flood has been reconstituted and the reservoirs have been operated on a theoretical after the event basis. Based on these calculations the Muskingum System would have reduced the flood crest at Coshocton to about 80,000 cfs, with about a 10 foot reduction of

stage. This reduced flood stage would still have created wide flood damage, but, not near as much as the 202,000 cfs natural flood.

As mentioned the record flood of March 1959 was also created by a combination of very heavy rainfall and melting ice and snow. The Coshocton USGS gage had a crest stage of 13.43 feet for this flood. This flood occurred after construction of the original Muskingum System, and the reservoirs were operated for the flood. Using the modified natural flow of 32,500 cfs, the computed natural flow is about 108,000 cfs. This reduced flood stage still created wide flood damage, and would have been much higher without the effect of the Muskingum System.

7-04. STANDING INSTRUCTIONS TO DAMTENDER

The Clendening Lake Damtender and staff operate the project in accordance with general instructions and Special Directives issued by the Water Management Section. This information is relayed through the Area Office to Clendening Lake project personnel.

a. Regulations. The above mentioned general instructions and Special Directives are written in accordance with regulations listed under Section 1-03 of this manual, Operating and Regulating Responsibility.

b. General Instructions. General instructions provide for routine reservoir regulation including the discharge limits, details of gate operation technique, collection and transmission of hydrologic and streamflow data, reservoir regulation at the start of a flood before contact can be made with the District Office, and emergency regulation in the event all communications fail during a flood. These instructions are contained in Exhibit B, "Instructions to Damtender ". These instructions establish the minimum number of observations to be made and are designed to ensure that any necessary gate operations will be promptly executed and that special reports will be initiated by the damtender before reservoir and stream conditions reach critical proportions. The general instructions apply at all times except when instructed by Special Directives from the Water Management Section.

c. Special Directives. Special Directives are issued by the Water Management Section to the Area Office for dissemination to the damtender. These directives are issued by telephone and confirmed by mail, and pertain to water control activities not covered by the general instructions. Special Directives are applicable for a specific operation or period of time and override the general instructions to the damtender. The following is a list of typical occurrences which could call for the issuance of a Special Directive.

(1) Flood control

(a) Outflow reduction for Muskingum Basin streams or Ohio River control.

(b) Release of flood storage and adjustments in rate of release.

(c) Above channel-capacity discharge when inflow hydrograph is greater than available storage capacity.

(2) Special regulation for:

- flow.
- (a) Construction activities downstream affected by
 - (b) Stream clean-up activities.
 - (c) Emergency - Drowning or pollutant spill.
 - (d) Complete closure for inspection on emergency or periodic basis.
- (3) Change in general instructions.
- (4) Any and all other pertinent operations as deemed necessary by Water Management Section.

7-05. FLOOD CONTROL

a. Requirements. Clendening Lake on Brushy Fork, along with Piedmont Lake on upper Stillwater Creek and Tappan Lake on Little Stillwater Creek control nearly 50 percent of the total Stillwater Creek Basin. Stillwater Creek is usually controlled through the optimal utilization and close coordination of all three Stillwater Creek Basin projects to adequately reduce total runoff during major floods up to a cloudburst.

Occasionally, summer thunderstorms containing heavy rainfall over a short period of time can be very destructive and produce intense local flooding. Because thunderstorms often affect only localized areas, it may be necessary to operate the Stillwater Creek Lakes as individual reservoirs for flood control during these types of storms.

Winter or spring-type storms can occur when soil, vegetation or snow cover conditions provide a high percentage or volume of runoff. These storms often cover more extensive areas and produce more generalized flooding conditions in the basin. These types of storms generally require operating several reservoirs for flood control. Accordingly, it may be advantageous to regulate Clendening, Tappan, Piedmont and possibly other Muskingum reservoirs by a comparison of available flood control storage at a given time. Outflow from these lakes is normally regulated to maintain no-damage stages at control gages on Stillwater Creek at Piedmont, Tippecanoe, and Uhrichsville, Ohio, and on Little Stillwater Creek at Tappan, Ohio.

b. Normal Plan. The major features of the regulation plan adopted for Clendening Lake appear in the succeeding paragraphs.

Clendening Lake is located on Brushy Fork, just above its confluence with Stillwater Creek, and controls approximately 69.3 square miles of the Brushy Fork Basin. For the reach below Clendening Lake and Brushy Fork, the no-damage stage is attained during the MIANO period (Mid-April through November) at a stage of 10.5 feet, and during the DEMIA period (December to Mid-April) at a stage of 12.0 feet on the stream gage, located on Stillwater Creek at Tippecanoe, Ohio. These stages at the stream gage have been selected as control stages for Clendening Lake.

The taking line for acquisition of lands within the Clendening Lake Project area is at spillway elevation 910.5 feet NGVD. Through detailed investigations of potential flooding damages to un-acquired property above the spillway elevation in the lake area, it has been determined

that damage to these properties which would result from the use of surcharge storage would be more than compensated for by the reduction in flood damages along Stillwater Creek, and the Tuscarawas, Muskingum, and Ohio Rivers.

(1) Regulation of Lake Level.

(a) Subject to flood control and low flow requirements, outflow is self-regulated by siphons, and by gates as necessary, to maintain the lake level at or near elevation 898.0 NGVD between the time elevation 898.0 NGVD is reached during spring filling and the beginning date of fall drawdown from the schedule annually proposed by the Muskingum Watershed Conservancy District (MWCD), usually 1 November.

(b) Subject to flood control, the outflow is regulated to release conservation storage by drawing down at a constant daily rate according to the MWCD schedule during the proposed time period for the drawdown, usually 30 days.

(c) Subject to flood control and low-flow requirements, the outflow will be regulated by sluice gates to maintain the lake level near the winter pool elevation proposed in the schedule, usually 893 feet NGVD, between the proposed dates.

(d) The pool level is raised to the summer recreation pool elevation, 898 feet NGVD, according to the MWCD schedule. An intermediate completion date suggested by MWCD, if inflow is sufficient, is usually met.

The Water Management Section accomplishes the above objectives for efficient operation of the lake by issuing Special Directives to the project utilizing the exhibits and plates in this manual. The Area Capacity table for Clendening Lake is shown on **Plate No. 7-1**, and Percent storage utilization is shown on **Plate No. 7-2**. The siphon rating curve is on **Plate No. 7-3**, the sluice gate rating curve is on **Plate No. 7-4**, the spillway discharge rating curve is on **Plate No. 7-5**, and the Lake Utilization Curve is **Plate No. 7-6**.

(2) Major Flood. Normal regulation for Stillwater Creek, and the Tuscarawas and Muskingum Rivers will be followed unless otherwise directed by the Water Management Section. If reservoir inflow is sufficient at Clendening Lake to exceed the spillway level, an assessment will be made of potential damages and the reservoir will be regulated to minimize total damages in the lake area and also downstream of the dam. Regulation will also be sensitive to temporary local concerns, potential loss of life, or damages to the project, which may override dollar values.

Following the utilization of the reservoir for flood control, it is desirable to reduce the flood storage as quickly as possible, considering any special operations, in view of the possibility of a major flood occurring at a time when the reservoir is partly filled.

c. Emergency Plan. In the event that all communication is disrupted between the Clendening Lake Project Office and the Huntington District Office, the Muskingum Area Office will assume regulation of the project. If communication is also lost between the project office and the area office, the Clendening Lake Damtender (Project Manager) will assume regulation for his project, as directed in Instructions to Damtender, Clendening Lake, in Exhibit B to this manual. For a major

flood where the flood pool approaches spillway elevation 910.5 feet NGVD, Exhibit B, Instructions to Damtender directs project personnel to open the gates as necessary up to seasonal channel capacity to prevent or retard the pool rise. If the pool continues to rise up to elevation 911.2 feet NGVD, the instructions direct project personnel to utilize additional gate discharge up to full gate capacity as necessary to prevent or retard further pool rise. When the pool crests and has receded to elevation 911.2 feet NGVD, gate openings are reduced to channel capacity discharge. When the pool has receded to spillway crest elevation 910.5, feet NGVD the pool is maintained at that elevation until communications are restored with the District or Area Office and a Special Directive for drawdown operation is issued.

7-06. RECREATION

a. Lake.

(1) Requirements. Recreational activities at Clendening Lake generally begin with fishing in March and continuing through October. The peak fishing season at Clendening Lake extends from April through September, with bass and crappie fishing being most popular in spring, and muskellunge, catfish and bluegill fishing being most popular during the summer. Muskingum Watershed Conservancy District lands are open to State hunting and trapping seasons that fall between Labor Day and Memorial Day.

For all recreational purposes, it is advantageous to maintain a nearly constant pool level. Large fluctuating pool levels may arouse visitor concern if they are unaware of the cause, and fluctuating levels affect boating safety by changing the normal view of the lake. Disorientation may occur to boaters or fishermen not familiar with the lake under variable pool levels, especially at Clendening Lake, which has a long shoreline with numerous tributary streams. Post rainfall pool rises can increase chances of boaters hitting newly inundated obstructions or grounding themselves near lake edges or in feeder streams. High levels also create difficulties in launching and retrieving boats. Lower lake levels bring submerged obstructions closer to the surface, creating possible snagging problems for boaters or fishermen.

(2) Control Plan. The water control plan at Clendening Lake attempts to maintain the pool at or near conservation elevation 898.0 feet NGVD during the recreation season. This pool level is maintained under normal conditions through the action of the two uncontrolled siphons in the outlet works of the dam. The siphons prevent unnecessary buildup of the lake level during normal inflow or minor storms. However, there are times when heavy runoff may require utilization of available flood storage at Clendening Lake, thereby causing a rise in water elevation at the lake. Part of the plan of regulation includes lake level and outflow rate forecasts.

b. Downstream.

(1) Requirements. Project personnel must maintain an awareness of downstream usage of Stillwater Creek for both recreation and other purposes since safety of these interests is of prime importance to lake regulation. Any interest accustomed to using the stream at low water should be notified of impending high discharges.

(2) Control Plan. In order to be aware of downstream activities, project personnel make occasional surveys, during both low

water and high water, to observe potentially hazardous situations.

In order to protect downstream interests, the water control plan limits maximum discharge rates and also the rate of increase or decrease of discharge in Stillwater Creek at the Tippecanoe "H" gage, except during an emergency. If a spillway flood should occur, project personnel would evacuate downstream areas and remove any equipment which could be damaged by high discharge.

7-07. WATER QUALITY AND LOW-FLOW CONTROL

Clendening Dam, was completed in 1936, the normal pool of 898 feet NGVD backs water 12.5 miles on Brushy Fork of Stillwater Creek. The outlet structure was not designed with maintenance or improvement of water quality as one of its purposes, therefore the quality of release water can not be regulated. Streambed elevation at the dam was 858 feet NGVD at the time of construction, but it had filled to 866 feet NGVD (water-quality lake profiles) in 2002. The lake stratifies during the summer with warm, oxygenated water in the epilimnion and colder water with little or no oxygen in the hypolimnion.

a. Requirements. Fish and food chain organisms require a continuous flow of oxygenated water for maintenance of normal vitality. Studies have shown that the natural flows are sufficient downstream from Clendening Lake for the maintenance of the fishery habitat. Therefore a minimum discharge of 1.5 cfs is deemed sufficient as an aid to the natural flows in habitat maintenance, and beneficial under dry conditions when natural flows are diminished.

b. Control Plan. Low-flow control and control of minor floods are accomplished by siphons in the outlet works when the pool level is at or above elevation 897.25 feet NGVD at Clendening Lake. A 1'-6" diameter siphon is located in each of the 2 outer conduits, and both siphons discharge into the middle conduit below the gates. A rating for the siphons is provided in **Plate No. 7-3**. The siphons were designed to maintain the conservation pool level under low-flow conditions without operation of the gates. During DEMIA (December to mid-April), or at other times when the pool level is below the invert of the siphons, elevation 897.25 feet NGVD, minimum and low-flow control is provided by operation of the slide gates. During the winter season, when the pool is near elevation 893 feet NGVD, the slide gates are usually fully closed. The required minimum 1.5 cfs flow will be met by utilizing the small amount of gate seepage, supplemented by "cracking" the center gate just enough to discharge the 1.5 cfs.

7-08. FISH AND WILDLIFE CONSERVATION

a. Requirements.

(1) Lake. In accordance with State Code and the lease agreement with the Muskingum Watershed Conservancy District, the Ohio Department of Natural Resources has the responsibility for conservation of fish and wildlife at Clendening Lake. Conservation requirements in the lake are met by various features of the Department management program which includes stocking the lake, monitoring populations, and administering licensing regulations for sportsmen.

Fluctuating lake levels affect fish and wildlife at Clendening Lake. A stable or rising pool is necessary for fish spawning. Rises in pool

levels in the spring can affect ground-nesting animals near the pool. Drawdowns affect waterfowl and furbearers by eliminating shallow-area feeding grounds. Drawdowns also affect hunters, especially during duck season, when shallow marsh areas are drained. Dry weather drawdowns expose muddy lake sides, and the erosion of boat waves can produce turbid water conditions an appreciable distance from the bank. This is the fertile littoral area into which fishermen cast. Fishing success suffers under such conditions because of the difficulty fish have in seeing the lures.

(2) Downstream. Habitat maintenance, including continuous flow of clean water at proper temperature, constitutes the conservation needs of the downstream aquatic community as to reservoir outflow. Lower food chain members which live on the bottom are dependent on clean rocks, gravel and sand for normal habitat. Silt and iron hydroxide, particularly under summer low-flow conditions, can coat this habitat making it unsuitable. This suppresses that basic portion of the food chain and depresses populations of higher members until the habitat is improved, as by flushing, and populations of lower members reestablished. Water in lower zones of the lake, subject to reducing conditions common during stratification, contains iron which is soluble in the reduced state. When this water is released and aerated in the stilling basin, the iron is changed to insoluble oxide by oxidation and hydrolyzed to the hydroxide mentioned above.

b. Control Plan. As explained in subparagraph 7-05a(1), the normal mode of regulation for both recreation and flood control fosters a stable pool; however, downstream flooding may require gate closure and consequent pool rise. Water Management Section exhibits flexibility in spring filling on behalf of fish spawning. When the Ohio Department of Natural Resources requests maintenance of a special pool level during a spawn, Water Resources Engineering Branch normally will honor the request if it does not interfere with other project purposes. Therefore, a minimum discharge of 1.5 cfs is maintained for the benefit of downstream fishery at Clendening Lake.

7-09. WATER SUPPLY - N.A.

7-10. HYDROELECTRIC POWER - N.A.

7-11. NAVIGATION - N.A.

7-12. DROUGHT CONTINGENCY PLAN. - See ANNEX I

7-13. FLOOD EMERGENCY ACTION PLANS

Although the Huntington District has developed standard responses to floods in district, the District does not yet have a specific Flood Emergency Action Plan for Clendening Lake. However, inundation maps have been prepared and provided to the district Emergency Management Branch for use in developing an Emergency Plan for Clendening Lake and for contact with State and local authorities. The District responses are basically dependant on whether or not the integrity of the dam has been threatened. Also, the Clendening Lake inundation maps have been provided to State and local authorities for their use in developing evacuation plans for the affected areas.

a. Inundation Mapping. Inundation Maps have been prepared for Clendening Lake for the upstream and downstream spillway design flood

with and without Dam failure. The maps were prepared in accordance with ER 1130-2-419 and show the time associated with the hypothetical flood wave. The inundation maps are to be stored in the Dam Safety Emergency Action Plan copies of which are located in OR-E-EC-GD, Clendening Lake, and the individual maps are stored in EC-W.

b. Floods Without Dam Integrity Problems. In the course of a flood, which does not threaten the integrity of the dam, the lake operations will be governed as described in 7-05. The Emergency Operations Center(EOC) will respond, based on the Commanders initiative, to the situation as described in the Policies contained in Natural Disaster Procedures, ER 500-1-1, 11 March 1991, which can be found in the EOC. The EOC may ask for periodic updates of the river situation from the Water Management Section or this briefing may be carried out during the briefing for the Commander.

c. Floods With Dam Integrity Problems. When a condition occurs which requires the project to operate to protect the integrity of the Dam and has the potential to be or is a significant hazard to life and property, the observing personnel will elevate the awareness of the situation to the appropriate individuals and take the appropriate action. Project personnel shall use the Clendening Lake Dam Safety Emergency Action Plan to determine what events will initiate this action and which individuals to contact. The Water Management Section will be kept informed of the situation as a result of the reporting requirements as defined in Exhibit B, **Plate No. 3-1**. Water Management Personnel will contact the Dam Safety officer when the lake rise indicates that alert pool will be achieved or exceeded and will keep the National Weather Service informed of any abnormal operations of the project. The Dam safety Officer is responsible for convening the Dam Safety Committee who is responsible for convening the Crisis Management Team. The District Engineer, the commanding Officer, the head of the Crisis Management Team, will open the EOC if he determines it is necessary.

7-14. OTHER PLANS

Clendening Lake does not require an operational change to combat mosquitoes, routine debris, ice jams, or the lowering of the local ground water table. If necessary these and other items are addressed in paragraph 7-15. The directory of key Emergency Personnel is located on page ii, one page before the Table of Contents of this manual.

7-15. DEVIATION FROM NORMAL REGULATION

The Huntington District Engineer is occasionally requested to deviate from the normal regulation of Clendening Lake. Approval and notification procedures are required when deviations from the normal water control plan are necessary. Prior approval for major deviations is required from the Division Engineer except as noted below. Deviation requests normally fall into the following categories.

a. Definitions

Major Deviation: Changes the normal operation of the project for a period of time greater than 5 days and elevation changes greater than two feet. A Major Deviation requires approval of both the Branch and Division levels.

Minor Deviation: A change in the normal operation that is less than the Major Deviation criteria. A Minor Deviation may be approved at

the Branch level with the concurrence at division level.

b. Types

1. Emergencies. The most common emergency that can be expected to occur at a project is a downstream drowning; decreased flow may be needed while searching for the victim or increased flow may be needed to dislodge the body. Other common accidents occurring at the project are failure of the operation facilities, chemical spills, treatment plan failures and other temporary pollution problems. Water control actions necessary to abate the problem are taken immediately unless such action would create equal or worse conditions. Districts must inform their division office as soon as practicable. Prepare written confirmation of the deviation and description of the cause and furnish it to the division water control manager. Divisions may develop forms to facilitate the reporting of emergency deviations.

2. Unplanned Minor Deviations. There are unplanned instances that create a temporary need for minor deviations from the normal regulation plan, although they are not considered emergencies. Requests for changes in release rates generally involve time periods ranging from a few hours to a few days. The following list contains most of the types of special regulations commonly requested: Legitimate interests, such as family to travel to and from home and burial processions on a road which traverses the Brushy Fork streambed, may require reduction of flow for safe crossing. Construction work, major or minor, including pipeline changes or repair, boat dock work, or testing of a finished facility may have various and changing flow requirements.

Each request is evaluated on its own merits. Consideration must be given to upstream watershed conditions, potential flood threat, condition of the lake, and alternative measures that can be taken. In the interest of maintaining good public relations, requests generally are complied with, providing there are no foreseen adverse effects on the overall regulation of the project (or projects) for the authorized purposes. These minor deviations are appropriately coordinated by telephone with the Water Management Section which may, at the time of coordination, request written confirmation showing the conditions and deviation on ORD Form 1018-R revised. Written confirmation is then furnished to the Division Water Control Manager.

3. Planned Major Deviations. Prior approval for major deviations is required from the Division Engineer as noted below. Either increase or decrease in outflow may be requested by other governmental agencies, including State and local, or by higher authority within the Corps of Engineers.

Each condition should be analyzed on its merits. Required data on flood potential, lake and watershed conditions, possible alternative measures, benefits to be expected and probable effects on other authorized and useful purposes, as mentioned above, are presented by letter, telephone or fax to the Great Lakes and Ohio River Division LRD office, along with recommendations for review and approval. Except in case of emergency, confirmation of a major deviation is necessary from the Great Lakes and Ohio River Water Control Center before the Water Management Section may grant a request.

In order for the Water Resources Engineering Branch and Division Office to gage the advisability of compliance with a request the Water

Management Section must investigate upstream watershed conditions, potential flood threat, impact on other project purposes, conditions of the lake, and possible alternatives. The LRD decision and approval and/or rejection is then returned in like manner to the project. The following list contains most of the types of major deviations commonly requested.

(1) Anticipated drought periods may require maintenance of additional storage in the lake for later release into the river system for downstream benefit.

(2) Special pool level for fishery enhancement. Measures, such as holding a specific higher pool level during and after the spawning period to foster recruitment, may be requested by State Fisheries Biologists to benefit populations of certain species or the entire fishery.

(3) All requests for special releases from Corps lakes for recreation such as canoeing, whitewater, or, other special releases will be referred to the Huntington District, Water Management Section of the Engineering-Construction Division for evaluation.

(4) Slow drawdown from rises during annually designated 2-week to 3-week period in May in behalf of bass spawn. Special lake drawdown in fall for species adjustment.

7-16. RATE OF RELEASE CHANGE

The Clendenning Lake outflow is to be regulated in such a manner that the rate of release does not fall below 1.5 cfs and the resulting stream level does not change more than 0.5 feet per hour.

SECTION VIII - RESULTS OF WATER CONTROL PLAN

8-01. GENERAL

The results of regulation for the authorized purposes of flood control, recreation, and fish and wildlife enhancement at Clendening Lake are presented in the following paragraphs and referenced plates. The results demonstrate the capability of the project to control and pass runoff from the basin for a series of historical and hypothetical floods. That capability is described in probability terms by the exhibits on Frequency of Filling (**Plate No. 8-1**) and Duration of Filling (**Plate No. 8-2**). The Frequency of Filling plate shows that Clendening Lake is likely to be filled to the spillway crest elevation once in approximately 300 years. Effects of the water control plan on recreation and fish and wildlife are also presented in later paragraphs.

Regulation of the Clendening Lake Project has been simulated, using historical data from the beginning of its operation in 1937. Data of the 27 year period (1962-1988) for inflow, outflow, and pool elevation in annual segments to facilitate review and understanding of the project during its life are on file in the Water Management Section.

8-02. FLOOD CONTROL

The Clendening Lake dam controls 69.3 square miles, or nearly all of the Brushy Fork drainage area. The combination of Clendening Lake, Piedmont Lake and Tappan Lake controls 226 square miles, or approximately 47% of the Stillwater Creek watershed area. The primary benefit of these 3 dams is the reduction of flood heights at Tippecanoe, Dennison and Uhrichville, with incidental benefits to Newcomerstown and all other downstream points on the Tuscarawas and Muskingum Rivers. The application of the adopted water control plan to 6 hypothetical floods, 3 historical floods and 3 recent floods as they occurred are discussed in subsequent paragraphs.

a. Hypothetical Floods.

Clendening Dam and the other Muskingum System dams were designed to control large hypothetical floods used during the 1930 building period. The original design series criteria were considered very good for the 1930's, but, each of them has been superceded by a more detailed modern series.

1. Spillway Design Flood (1930). The original Spillway Design Flood (SDF) was the basis for determining the spillway capacity required to provide for the safety of Clendening Dam during the most critical flood over the basin. The adequacy of the outlets for passing flood flows without overtopping the spillway crest was further investigated by their capacity to control maximum flows resulting from three other hypothetical floods. The Board of Consulting Engineers for the Muskingum Watershed Conservancy District adopted three general criteria for fixing spillway capacities at each reservoir. The spillway was to be of sufficient capacity to meet the requirements of whichever criterion proved to be the most severe in each individual case. The assumptions made for each of the criteria are given below, and are summarized in **Table No. 8-1**, next page.

Table No. 8-1				
Criteria For Original Spillway Design Flood				
Criterion	Initial Pool Elevation	Operation Plan of Clendening Dam	Flood Volume	
			Inches of Runoff	Ac-ft
I	898.0	All outlets closed	16.0	59,800
II	910.5	All outlets closed	16.0	59,800
III	898.0	Outlets operated according to the Official Plan until spillway crest reached, then outlets fully opened	16.8	62,800

(1) Criterion I. The reservoir was assumed to be at or slightly above the summer recreation pool elevation of 898.0 feet NGVD at the beginning of the flood. The summer plan was intended to keep the pool at this elevation at all times.

A freeboard of 2 feet was to be maintained below the top of the dam. The outlets were assumed to be closed throughout the flood. This was to provide for the possibility of all the gates being stuck in the closed position, or being completely blocked or plugged with debris.

The peak inflow was determined from the adopted envelope curve of 1913 peak flows in the Miami Basin plotted against drainage area. The 1913 envelope curve gave the 70 square-mile Clendening Lake drainage basin a peak inflow of 500 cfs per square mile, or 34,500 cfs. The duration of inflow was arbitrarily set at 3 days.

The total volume of runoff from the curve adopted for this criterion, of runoff versus drainage area, gave a total runoff of 16.0 inches, or 59,800 acre-feet.

(2) Criterion II. This criterion insured sufficient spillway capacity to provide for the possibility of a large flood occurring with the reservoir already filled to the spillway crest. It differed from Criterion I only as follows:

Clendening Lake was assumed to be filled to the spillway crest of 910.5 feet NGVD at the onset of the flood. A freeboard of 2 feet was to be maintained below the top of the dam.

(3) Criterion III. This criterion insured that an extremely large flood could come upon the reservoir at the recreation pool level, and be passed through the reservoir by operating the outlets, such that the resulting pool did not reach within 2 feet of the top of the dam. It differed from Criterion I only as follows:

The outlets were assumed to be operated as for the Official Plan Flood until the spillway was reached, then the gates were to be opened. The total volume of runoff from the curve adopted for this criterion of total runoff versus drainage area, gave a total runoff of 16.8 inches or 62,800 acre-feet.

The results of applying the three criteria indicated that Criterion II

was the ruling criterion, and the inflow raised the pool to elevation 923.5 feet NGVD, or 2.0 feet below the top of dam elevation. Criteria I and III were less severe, raising the pool levels to elevations 919.5 feet NGVD and 918.6 feet NGVD, respectively. Inflow hydrographs for the three criteria floods are shown on **Plate No. 8-3**.

The Board of Consulting Engineers also decided that the outlets at Clendening Lake should be at least large enough that the 5-day Inflow Flood could have a total volume of 9 inches. That required an outlet capacity at full pool of 1,400 cfs, which became the ruling criterion, since this 1,400 cfs outflow greatly exceeded the outflow required by the Official Plan Flood criterion. The conduits at Clendening Lake were designed for this capacity.

(1) A 5-day Storm Flood. This was a flood resulting from a 5-day storm which was proportional to the Official Plan Flood. The natural duration of the flood at the dam site was about 7 days, with a total runoff of 10.1 inches. Accordingly, Clendening Dam was designed for a storm with 10.1 inches of runoff.

(2) A 3-day Storm Flood. This was a flood resulting from a 3-day storm, with a rainfall distribution of 25 percent the first day, 52.5 percent the second day, and 22.5 percent the third day. The natural duration of the flood at the dam site was about 5 days, with a total runoff of 8.7 inches.

(3) A 3-day Inflow Flood. This was an inflow flood with a duration arbitrarily set at 3 days, with a hydrograph that was roughly triangular, and a total runoff of 9.3 inches.

2. Official Plan Flood. The Official Plan Flood was one of several criteria utilized for the design of Clendening Lake. The Official Plan Flood was assumed to be the largest general flood that could occur in the Muskingum River Basin. It consisted of 10 inches of rainfall falling over a period of 5 days, with a runoff factor of 90 percent. The rainfall distribution was assumed to be proportional to that of the 1913 flood for the Muskingum River Basin above Coshocton.

One criterion used to determine the capacity of the outlets was the ability to pass, with one gate closed, an average of 15 percent in excess of the 1,400 cfs required by the desired operation of the outlets during the Official Plan Flood. The consideration of one gate being closed was to allow for the possibility of one gate becoming immovable in the closed position, or of the inlet becoming obstructed with debris. The 15 percent increase in capacity gave a greater flexibility of operation and was considered as a safety factor in case a large flood was not detected in advance, resulting in excess storage of flow in the early stages of the flood. The average excess in capacity was determined to be 24 percent during the Official Plan Flood, which was above the requirements of that criterion. The results of routing the Official Plan Flood with current operating guidelines are shown on **Plate No. 8-3**.

3. Modern Spillway Design Floods. At the time of construction of Clendening Dam the present day concept of a Spillway Design Flood (SDF) or a Standard Project Flood (SPF) had not yet been developed. As previously mentioned, during the 1930's, Clendening Dam was designed for a storm based on 16.0 inches of runoff. The inflow hydrograph crested at about 34,500 cfs, and was placed on a full spillway pool of 910.5 NGVD. This flood produced a crest of about 923.5 feet NGVD with 2.0 feet of freeboard.

During the 1940's new spillway design flood criteria was developed and adopted by the Corps of Engineers. This new criteria is the basis for determination of the spillway capacity required to provide complete safety of the dam during the most critical storm runoff over the basin. And, the adopted standard project flood constitutes a standard for design of structures that will provide a high degree of protection as determined by flood potentialities of the selected drainage area without any regard to economic or physical limitations. When the modern Spillway Design Storm (SDS) was developed, the criteria was informally applied, on an after the fact basis to Clendening Dam, and the spillway was computed to be slightly inadequate.

Later still, the contract for an evaluation and study of the entire Muskingum System for Spillway Adequacy and Replacement was awarded to the Dodson-Lindbloom Co. of Columbus, Ohio. This detailed study was undertaken in 1975 with the overall plan of evaluating and comparing the original Muskingum System of 14 reservoirs, plus 2 additional lakes, by current 1975 criteria. The 1975 study was based on Hydromet Bulletin No. 33, defined as the theoretically greatest depth of precipitation or probable maximum 48 hour storm or SDS over a particular drainage area at a certain time of year in the eastern United States. The recommended full pool freeboard was 3 feet, and the half pool limit was 5 feet.

Detailed unit hydrographs were developed from individual storms and the SDS rainfall was applied, with the storm centered over the uncontrolled area above Clendening Dam. The pool routings were natural conditions, no dam; followed by a full pool elevation 910.5 routing, and the third routing on a 50% half pool. The Spillway Design Storm had 25.06 inches of rain, with 22.24 inches of runoff, with a natural hydrograph peak of 36,300 cfs, and a "B" inflow hydrograph peaking at 49,100 cfs. The pool crest for the full pool was 924.5 feet NGVD with a peak outflow of 20,810 cfs, while the half pool crest was 923.0 feet NGVD with a peak outflow of 18,100 cfs. Since the existing top of dam was elevation 925.5 feet NGVD, the two floods left a freeboard of 1.0 and 2.5 feet, respectively. Based on this study the original Clendening Dam and spillway was capable of safely passing 100 percent of the Hydromet No. 33 (SDF) on both a full pool, and a half-pool; however, the full pool freeboard was 1 foot short of the old original 2 foot limit, and was 2.0 and 2.5 feet short on the new 3 and 5 foot freeboard limit. This spillway Design Flood operation is shown on **Plate No. 8-4**.

When the Dam Safety Assurance program was initiated for the Huntington District in 1982 Clendening Lake spillway was again informally evaluated by using the SDF reviewed in the previous paragraph using probable maximum rainfall shown in Hydrometeorological Report No. 33. Later in 1982, the same Dodson-Lindbloom Associates of Columbus performed a dam break study for Clendening Dam. Flood waves were determined for failure of the dam during the 1975 Spillway Design Flood (SDF) and with the reservoir level at elevation 910.5 feet NGVD. Flood waves were also determined for the SDF without failure. The study provided estimated wave heights and arrival times at several locations downstream of Clendening Dam as well as maps of the areas inundated during the SDF with and without failure. All these previous studies have shown the spillway design at Clendening Dam to be slightly inadequate by modern design criteria. At the same time, the Clendening Lake spillway has never been overtopped during any flood.

Current Corps criteria specify that the Spillway Design Flood (SDF) be based on the runoff from the Probable Maximum Precipitation (PMP), as indicated in Hydromet Reports 51 and 52. The CELRD further requires

that the PMP be used with an antecedent storm of 39%(PMP) for 72 hours followed by a 120 hour dry period. Clendening Dam has never been computer operated for this storm, however, it is currently on a list of dams to be tested for hydrologic deficiency using the current Hydrometeorological 51 and 52 under the Dam Safety Assurance Program.

Further detailed study will determine the necessary changes in dam elevation and spillway capacity, and the efforts required to remedy the deficiency. When this operation is completed the operational hydrograph will be forwarded to all concerned parties.

4. Standard Project Flood. The standard project flood is a modern replacement for the original 1930 Official Plan Flood, and constitutes a standard for design of structures that will provide a high degree of protection as determined by flood potentialities of the drainage area involved without regard to economic or physical limitations.

This theoretical flood would result from a storm probably in July or August designed to equal the worst combination of meteorological and hydrologic conditions considered reasonably characteristic of the area. It was determined from generalized rainfall criteria and procedures outlined in EM 1110-2-1411. A review of summer-type storms indicated that a minimum infiltration rate of 0.05 inch per hour might be experienced and this value was adopted in determining the rainfall excess. Based on studies of stream flow records for the Muskingum River, a base flow of 1 cfs per square mile was adopted. The total excess rainfall for this flood would be about 11.0 inches, and the sluice gates must be used for the rising pool levels above elevation 909 feet NGVD. Spillway and sluice discharge would rise concurrently with hourly gate adjustments to the maximum outflow. The sluice gate settings would be maintained until the pool crested and receded to maximum flood control pool elevation 910.5 feet NGVD, and then would be regulated to maintain that pool level. As soon as downstream conditions permitted, the Water Management Section would direct discharge of flood storage. Releases would be made through the sluice gates until the lake level receded to elevation 898 feet NGVD, at which time normal operations would be resumed.

b. Representative Floods.

(1) General. The historical floods which were selected for illustration of the water control plan are the floods of March 1913, August 1935 and January 1937. Also selected were the floods of January 1959, February 1979, and August 1980 which illustrate floods actually regulated according to the water control plan. The flood of March 1913 was caused by widespread heavy rains which resulted in record stages along the Tuscarawas River. The flood of August 1935 was caused by widespread heavy rains falling on saturated ground and resulted in record peaks for a summer storm on many streams. The flood of January 1937, which occurred when the Muskingum River Basin reservoir system was under construction, stemmed from a series of severe storms and resulted in record stages along the Ohio River. The flood of January 1959 resulted from generalized rains with high runoff due to the saturated, frozen and snow-covered ground. The flood of February 1979 was caused by antecedent snowmelt and moderate rainfall falling on snow-covered and frozen ground. The flood of August 1980 resulted from a series of locally intense random thundershowers falling on saturated ground and already rain-swollen streams.

(2) Flood of March 1913. The flood of March 1913 resulted

from excessive precipitation over a comparatively large area causing large volumes of water to be dumped into the streams throughout the Tuscarawas River Basin. The rain was exceptionally heavy through the northern sections of Ohio, amounting to 10 inches or more in some areas. The winter had been mild, and the ground was already saturated from the heavy rains of January and the first portion of March. In the Tuscarawas River Basin, the main storm began just before noon on 23 March, became increasingly heavy the next two days, and continued on the 26th and in some portions of the basin on the 27th. Total rainfall for the storm, most of which occurred in a 96-hour period or less at individual locations, averaged 6.55 inches over the Tuscarawas River Basin. No rainfall measurements were made within the Clendening Lake Basin, but at Cadiz, just east of the basin's headwaters, total rainfall for the storm was 5.67 inches.

Neither Clendening Lake nor any of the flood control dams in the Muskingum River Basin was built at the time, but the flood has been reconstituted. The computed inflow crest at Clendening Lake was 3,560 cfs on 27 March. In the reconstituted operation at Clendening Lake, most of the inflow from the flood was stored in the reservoir, except for the siphon outflow and a short period of gate operation on 24 March at the onset of the flood. The maximum pool level obtained at Clendening Lake was elevation 906.11 feet NGVD on 30 March. The gates were gradually opened to pass a maximum outflow of 540 cfs (downstream channel capacity) by 2 April to draw down the flood pool. Results of regulation of this flood at Clendening Lake are given in **Plate No. 8-5**.

The hydrographs shown in this and subsequent exhibits labeled "natural" represent the flow conditions that would exist without the Clendening Lake Project, and those labeled "modified" represent the inflow conditions that exist with the project. The outflow hydrograph represents the regulated outflow from Clendening Lake.

(3) Flood of August 1935. The flood of 6-7 August 1935 is one of the largest general summer floods to affect the Muskingum River Basin. A series of storms from the end of July through 4 August raised basin streams and decreased soil retention capacities. Heavy rainfalls on 6 and 7 August, averaging 4.1 inches in less than 12 hours in the Muskingum River Basin created large runoff volumes which produced the highest summer stages of record on the Tuscarawas River below Dover.

The dam at Clendening Lake was under construction when the flood occurred, but the flood has been reconstituted. The major inflow peak of 1,005 cfs occurred on 8 August. Outflow was limited to that which passed through the siphons during the flood. The gates were then opened on 13 August to begin drawing down the flood pool. The maximum pool level calculated for this flood was elevation 901.04 feet NGVD on 13 August. Results of regulation of this flood are shown on **Plate No. 8-6**.

(4) Flood of January 1937. This flood was caused by a series of storms beginning on 26 December 1936 and continuing through most of January 1937. The storm was centered in Tennessee, but produced an average of 7.93 inches of rainfall in the southern and western portions of the Muskingum River Basin during the period of 14-25 January. Tributary streams experienced successions of flood rises which accumulated in the larger rivers and caused increasingly higher stages in them. The Muskingum River Basin experienced the second highest flood of record at many locations, including on the Tuscarawas River just below Dover Dam. The flood control structures in the Muskingum system were partially completed and acted as automatic retarding basins to decrease downstream stages and discharges.

The Clendening Lake dam was still under construction when the flood occurred, but the flood has been reconstituted. Brushy Fork experienced several flood peaks during January, with the 2 major peaks of approximately 2,500 cfs and 2,330 cfs occurring on 22 and 24 January, respectively. The gates were gradually closed on 15 January to store inflow from the flood. All inflow was stored from that point until the pool level reached the invert of the siphons on 21 January. Outflow was then limited to that which passed through the siphons during the major flooding period, until the gates were opened on 30 January to draw down the flood pool. The maximum pool level calculated for this flood was elevation 905.51 feet NGVD on 29 January. Results of regulation of this flood are shown on **Plate No. 8-7**.

(5) Flood of January 1959. The flood of January 1959 generally ranks as the second or third largest flood of record on tributaries not controlled by reservoirs. Antecedent conditions prior to the flood contributed greatly to the magnitude of the flood stages throughout the basin. Severe cold weather during December 1958 froze the ground to depths of 6 to 18 inches prior to the storm. Precipitation of approximately 1 inch occurred between 14-17 January, which saturated the ground. The ground was thus frozen, saturated and covered with about 5 to 6 inches of snow prior to the main storm. A large amount of runoff therefore occurred when the generalized flood-producing rain began about midnight on 20 January. Most of the rain fell in a 12-hour period, with the Clendening Lake Basin receiving approximately 1.5 inches of rainfall from the storm.

Prior to the main storm of 20-21 January, the pool level at Clendening Lake was at elevation 898 feet NGVD. Outflow from Clendening Lake was being regulated by the siphons only. At the onset of the storm, gates were opened gradually to pass a peak outflow of approximately 200 cfs. The gates were then closed in the early afternoon on 21 January at the time of the peak inflow of 1,930 cfs to store the remaining inflow, with siphon flow accounting for all the outflow from the reservoir. The gates remained closed until the evening of 24 January when the inflow to the reservoir had dropped to below 300 cfs. Gates were then opened to pass a maximum of 525 cfs (downstream channel capacity) and to draw down the flood pool. The flood pool reached its maximum level of elevation 900.44 feet NGVD on 24 January, just prior to the beginning of pool drawdown. Results of regulation of this flood are on **Plate No. 8-8**.

(6) Flood of February 1979. Subfreezing temperatures and a major snow cover persisted over the Muskingum River Basin during most of January and February 1979. Rising temperatures and light rainfall on 21-22 February created thawing conditions which persisted until moderate rainfall on 25-26 February, combined with rapid snowmelt, created flooding conditions in the Muskingum River Basin. Rainfalls averaged only approximately 1.5 inches but combined with snowmelt from 6-20 inches of snow cover on the basin. At Clendening Lake, snow cover was approximately 14 inches, with a rainfall of 1.48 inches. It is estimated that the operation of the flood control structures in the Stillwater Creek Basin reduced flood stages by 4.3 feet at the Uhrichsville gage during the flood of February 1979. The maximum inflow peak recorded at Clendening Lake for this flood was approximately 5100 cfs on 25 February. The gates were operated during the early rainfalls of 21-22 February, but the gates were closed at noon on 22 February to store inflow for the remainder of the storm. The rising pool level reached the invert of the siphons on 25 February, and outflow was restricted to that which passed through the siphons until the gates were opened on 5 March to draw down the flood pool. The

maximum pool level observed for this storm was elevation 900.47 feet NGVD on 6 March. Results of regulation of this flood are shown on **Plate No. 8-9.**

(7) Flood of August 1980. A series of widespread intense thunderstorms were responsible for major rises in stream levels during August 1980. Due to above-normal precipitation during the previous two months, soil conditions were generally saturated in the region, producing substantial runoff from the storms in August. Rainfalls of 1-2 inches were common over the Muskingum River Basin from the storms of 2-6 August, 9-12 August, 17-19 August, and 21-22 August. The major rainfalls at Clendening Lake occurred during the periods of 2-6 August with 3.58 inches of rain, 9-12 August with 3.95 inches of rain, and 17-18 August with 2.76 inches of rain. In the Stillwater Creek Basin, it is estimated that the operation of the flood control structures reduced flood stages for the storms of 3-16 August by 2.5 feet at Tippecanoe and 3.8 feet at Uhrichsville. For the flood of 16-20 August, flood stage reductions were estimated to be 3.8 feet at Tippecanoe and 4.2 feet at Uhrichsville.

At Clendening Lake, the major peak inflow of approximately 8,050 cfs occurred on 18 August. Other smaller peak flows exceeding 1,000 cfs occurred on 11 and 21 August. Gate operations from the storms of early August were terminated on 10 August, and except for a short period of gate operation on 17 August, outflow was limited to siphon flow for the period of 11-20 August. Gate operations resumed on 21 August to begin drawing down the flood pool. The maximum flood pool of record occurred at Clendening Lake during this flood at elevation 909.00 feet NGVD. Approximately 86% of the available flood control storage at Clendening Lake was utilized. Results of regulation of this flood are shown on **Plate No. 8-10.**

c. Benefits. Since their construction in the 1930's, the 14 original dams in the Muskingum River Basin reservoir system have continued to significantly reduce flood damages in the basin. Based on Corps of Engineers estimates of flood damages for both the natural condition and as modified by the reservoir system, the 14 original dams have helped prevent an estimated \$2.07 Billion dollars in accumulated total flood damages from 1936 through FY-98, or 30 September 1998. However, this is an accumulated, year to year amount, and does not reflect the adjustments for inflation, depreciation, or new construction.

Studies have been undertaken in the past to determine the relative percentage of flooding benefits afforded by each of the 14 Muskingum River Basin projects. These studies analyzed the contribution of each project for a number of selected Muskingum and Ohio River floods. Based on these studies, it was determined that the Clendening Lake project on its own was responsible for approximately 2.1% of the total Ohio River benefits afforded by the 14 Muskingum River Basin projects. Using the above total damage figure of \$2.07 Billion dollars, this would be a total of about \$44 million benefit dollars credited to Clendening Lake. For the last five years the total damages prevented for the system was about \$629 million dollars. The current amount credited for Clendening Dam would be about \$2.6 million dollars per year.

8-03. RECREATION

Success of the recreational purpose of the project, as measured by the number of visitors, has been excellent. Although no head count is made

of the number of visitors at any of the Muskingum River Basin recreational facilities, it is estimated that approximately 3.5 million visits are made to the Muskingum River Basin lakes and parks each year.

Changes in pool level tend to diminish recreational benefits by affecting boating, camping, hunting and fishing interests at Clendening Lake. Public campgrounds, concession areas and roads around Clendening Lake are susceptible to damages caused by high water levels.

Before the recreational phase of the Muskingum River Basin was initiated, the National Park Service assisted the Muskingum Watershed Conservancy District in the 1940's in estimating the recreational value of the Muskingum River Basin projects. The value was estimated to be \$807,000 per year. Thirty years later, conservative estimates placed the annual value in excess of \$5 million dollars. The total investment in recreational facilities in the Muskingum River Basin projects has been approximately \$10 million; the estimated cost of duplicating the recreation values provided by the District is in excess of \$150 million.

8-04. WATER QUALITY

a. Special Problems. Existing mining problems within the watershed are the most significant water quality problems. Problems associated with mining include elevated levels of specific conductance, sulfates, chlorides, and metals. In 1977 the Waterways Experiment Station conducted a study on the concrete deterioration in the outlet tunnels of Clendening Lake. They found the deterioration is most likely due to acid attack and is the final stage of a corrosive process caused by sulfur bacteria action. The hydrogen sulfide gas comes from the sulfate-rich waters in the lake and from anaerobic decomposition of organics in the sediment.

An interdisciplinary approach is used to evaluate the physics, chemistry, and biology of inflow streams, the lake, and the outflow. The following interpretations are based on data collected between 1983 and 2002.

b. Physical/Chemical. The chemical composition of water may be defined by grouping substances, which compose the dissolved solids. Relationships among groups of chemicals determine the type of water. In terms of major ions and descriptive parameters, water in Clendening Lake is classified as a calcium-sulfate type. This represents an unbalanced condition.

Impounded waters are in more or less dynamic states. The governing factor in water quality development is the temporal and spatial behavior of the density of this water. In most fresh water systems, water temperature is the predominant factor in determining density. Temperature variations in water masses are capable of creating strata of water of greatly different characteristics. Such differing characteristics have direct implications with regard to lake-releases.

Most lakes in this part of the country remain nearly isothermal during the winter months. In the spring, under normal conditions, they will stratify and remain so until sometime in the fall. At that time the lakes mix and become isothermal again.

c. Temperature. A lake structure will typically cycle from a mixed condition (Temperature same from top to bottom) to a stratified or layered condition (Temperature changes with depth). This

is the result of thermal energy from the atmosphere gained and lost during the year. During spring as air temperatures start to warm, so do surface water temperatures. This creates a surface layer called the epilimnion. Water temperatures near the bottom remain cool because they are not exposed to sunlight or warmer air temperatures. This layer is referred to as the hypolimnion. The layer in the middle is called the metalimnion or transition layer. During fall when air temperatures start to cool the surface water temperature also cools and mixes with water below at the same temperature. This process continues until water temperature in the epilimnion is the same as the hypolimnion and the lake is once again mixed. Clendening Lake remains nearly isothermal during the winter months. In the spring the lake starts to stratify. **Plate No. 8-12** Shows a typical temperature profile while the lake is stratified.

d. Retention. The calculated average retention time of 169 days is long (compared to other projects within the District) and should affect thermal stratification. It is expected that significant stratification would exist with such a long retention time, but the design of the outflow structure allows for only the release of bottom waters. Only a well defined epilimnion exists. The metalimnion, and hypolimnion blend together. Water in the upper part of the lake remains there for longer periods of time.

e. Dissolved Oxygen. Dissolved oxygen levels are extremely important in water quality characterization. They depend on the physical, chemical, and biological activities that occur in water. Dissolved oxygen saturation limits are directly related to temperature and thermal stratification can result in zones that exhibit greatly different characteristics. In well-mixed epilimnetic waters, relatively high levels of dissolved oxygen occur and the water is usually of acceptable quality. Although, water in the hypolimnion may become void of oxygen as a result of various oxygen demanding processes. Therefore, a concomitant decrease in water quality can occur after stratification becomes established. Concentrations of dissolved oxygen in Clendening Lake were constant throughout the water column after fall mixing completed, and remained so until April when the lake showed signs of thermal stratification. At that time, dissolved oxygen levels near the bottom declined until anoxic conditions were reached. Dissolved oxygen remained above 5.0 mg/l through the first 10 feet. This implied that a maximum of 54 percent of the lake was available for fishing during summer stratification. Dissolved oxygen is one of the key parameters for fishing which indicates that only a little more than 1/2 of the lake was available during the months July through September. **Plate No. 8-13** shows a typical dissolved oxygen profile during the summer months. During fall turnover, the lake mixes and dissolved oxygen is redistributed throughout the water column.

Brushy Fork is the major inflow to Clendening Lake. Dissolved oxygen concentrations in Brushy Fork averaged 101% saturation which indicates a good condition. Clendening Lake averaged 81% saturation which is good. Average values in the tailwater were 93% saturation. The outflow system was not designed to allow for regulation of the quality of water, but there is significant aeration in the stilling basin.

During the summer months water released from the lake had a dissolved oxygen concentration of 0.0 mg/l. By the time it left the stilling basin dissolved oxygen values increased to just over 80%.

f. Nutrient Load. Concentrations of nutrients in a lake are an indicator of productivity. Low productivity results in fewer littoral plants and low density of phytoplankton, whereas littoral plants and abundant phytoplankton populations characterize highly productive lakes. The amount of productivity is directly related to the lake fishery. Sufficient quantities of phosphorous, nitrogen, and carbon are needed to have a productive lake such as Clendening Lake, but phosphorous is the limiting nutrient. As long as there is available phosphorous, the food supply is not limiting productivity.

Nutrients are transported with sediments. As water enters a lake, its velocity decreases and the sediments settle to the bottom. Because of this phenomenon, it is common to see algal blooms at the upper end of a lake. Phosphorous concentrations averaged 0.03 mg/l at the inflows and 0.12 mg/l in the outflow which indicated that there was available phosphorous in the tailwaters.

g. pH. PH is a measure of the hydrogen ion concentration. It can be increased by adding a base or removing carbon dioxide from a solution such as in photosynthetic assimilation. By definition, pH ranges from 1 to 14 and a pH value of 7.0 is considered neutral. The average pH value found in the database for headwater stations was 7.8 as compared to 7.6 at the tailwater station. Long-term trends indicate no significant pattern in pH values over the watershed.

While pH is a measure of concentration, alkalinity is a measure of capacity. The capacity of a solution to neutralize acids or bases is called buffering capacity. Average alkalinity, a factor buffering pH, was around 156 mg/l CaCO₃ in the headwaters and 119 mg/l CaCO₃ in the tailwaters. These numbers indicate sufficient buffering capacity in the system.

h. Hardness. Water hardness is the sum of calcium and magnesium concentrations expressed in terms of mg/l calcium carbonate. It is largely a result of geological formations at the water source. Calcium and magnesium form an insoluble residue with soap and leave deposits on surfaces that come in contact with the water. The ring around a bathtub is a well-known example of these deposits. Detergents were introduced to reduce this problem. High hardness (hard water) results in high soap consumption as well as objectionable scale in heating vessels and pipes. Public acceptance of hardness varies. Many consumers will object to water harder than 150 mg/l calcium carbonate (Water Supply and Pollution Control).

Average water hardness in inflows to the lake was 830 mg/l calcium carbonate and was 401 mg/l calcium carbonate in the tailwater. This range is classified as "very hard" based on U.S. Geological Survey classifications.

i. Sulfates. Sulfates are widely distributed in nature. Although there is no standard for sulfate in surface waters, sulfate is listed under EPA's Secondary Maximum Contaminant Level for drinking water (SMCL). Secondary standards are based on taste, odor, color, corrosivity, foaming and staining properties of water. Sulfate minerals can cause scale buildup in water pipes similar to other minerals and may be associated with a bitter taste in water. Sulfates may also have a laxative effect that can lead to dehydration. With time, people and young livestock become acclimated to the sulfates and the symptoms disappear. The SMCL standard for sulfate is 250 mg/l.

The average concentration of sulfate in the inflows to the lake was 987 mg/l which is much higher than the SMCL standard. The average sulfate concentration in the outflow was 288 mg/l which is about a third of the inflow level, but is still a little above the SMCL standard.

j. Iron Concentration. Iron is an abundant element on the earth, but usually occurs as an insoluble form in water and at low concentrations. The average concentration of iron in the inflow waters to Clendening Lake was 259 ug/l. This is slightly higher than the average value of 188 ug/l found in the tailwaters. Both are well within the limits for surface water standards. During the stratification season, average iron levels in the lake were also below the recommended limit of 1000 ug/l (**Plate No. 8-14**). Long-term trends indicated no significant changes in iron concentrations.

k. Manganese Concentration. Manganese levels in the headwaters were well below a standard of 1000 ug/l, averaging 126 ug/l. During lake stratification, manganese concentrations in the hypolimnion were much higher (**Plate No. 8-15**). The average manganese concentration in the tailwater area was 539 ug/l. This is a significant increase over headwater conditions and is attributed to the bottom-level-releases from the lake. During stratification, manganese levels in the tailwaters can exceed 3000 ug/l. Long-term trends indicated no significant change in manganese concentrations.

l. Biological. In a freshwater community, algae are the primary producers. They serve as the basis of the food chain and are the primary food source for most aquatic animals. The quantity and types of algae present in a stream or lake are dependent upon many factors, such as temperature, oxygen, light, nutrients and flow. All freshwater algae contain the green pigment chlorophyll. Therefore, measuring chlorophyll can monitor the productivity of aquatic habitats.

Algal productivity was low in headwater streams with an average chlorophyll concentration of 4 ug/l. Productivity on the lake was considered a good with an average chlorophyll concentration of 14ug/l.

Freshwater macroinvertebrates (aquatic insects and worms, crayfish, mussels, etc.) serve as a useful tool for evaluating environmental impacts that occur over time. Because of their limited mobility and their relatively long life span, these organisms are subjected to the environmental conditions of their immediate aquatic habitat. Macroinvertebrates have been used as an assessment parameter to evaluate the overall water quality conditions for the outflow station CLB0004 (Brushy Fork) and the primary inflow station CLB0006 (Brushy Fork) and the secondary inflow station CLB0007 (Elk Run).

OVERALL QUALITY RATING: OQR is derived from the BMWP score and the ASPT. The **BMWP** (Biological Monitoring Working Party) was designed to give a broad indication of the biological condition of rivers and streams. Identification of organisms, from macroinvertebrate samples, is made to the family level. Each family is given a score, between 1 and 10, depending on their susceptibility to pollution. Taxa least tolerant, such as families of mayflies and stoneflies, are given the highest scores. The BMWP score is the sum of the family scores. The BMWP score is then divided by the number of families to produce the Average Score per Taxon (ASPT). The calculated BMWP score (X) and ASPT (Y) are then give a rating between 1 and 7, depending on whether the site or station is classed as a habitat-rich riffle, or a habitat-

poor riffle/pool. The overall quality rating is derived as $OQR=X+Y/2$.

The **OQR** and interpretation for the above water quality stations are presented in **Plate No. 8-16**. Data is based on benthic samples collected from 1976 through 1999 for CLB0004; 1978 through 1999 for CLB0006; and 1991 through 1999 for CLB0007. Both inflow stations have a **moderate** rating, while the outflow station has a **poor** rating.

The most common groups of macroinvertebrates collected in the benthic samples from the outflow station were hydras (21%), aquatic worms (25%), and dipterans (50%), primarily chironomid midges. The common groups collected at the inflow station on Brushy Fork were caddisflies (33%), aquatic beetles (21%), and midges (27%); and the secondary inflow station on Elk Run were caddisflies (13%), aquatic beetles (12%), and midges (41%). Percent **EPT** (percent of the composite of mayfly, stonefly, and caddisfly larvae) for the outflow was 0.24%; for Brushy Fork was 40.41%; and for Elk Run was 23.19%. Mayflies were rare in the benthic samples at all three stations. The outflow had only 0.07% mayflies from the samples, while Brushy Fork had 0.15%, and Elk Run had 0.05%. The low numbers of mayflies collected is probably the result of elevated specific conductance and concentrations of sulfate related to pass mining in the watershed.

8-05. FISH AND WILDLIFE

Effects of the water control plan on fish and wildlife at Clendening Lake are associated mainly with pool level fluctuations in the lake and outflow from the outlet works.

Requirements of a constant or rising pool for fish spawning are incorporated into the water control plan at Clendening Lake. Walleyes need steady or rising pool elevations beginning in mid-March, which falls during the spring refilling period. Largemouth bass normally spawn in May, after the pool has reached the conservation pool level. The water plan at Clendening Lake will normally provide adequate pool conditions for fish spawning.

8-06. WATER SUPPLY - N.A.

8-07. HYDROELECTRIC POWER - N.A.

8-08. NAVIGATION - N.A.

8-09. DROUGHT CONTINGENCY PLANS - N.A.

8-10. FLOOD EMERGENCY ACTION PLANS

Since the Clendening Lake project has been operational, no emergency drawdown has occurred. The time required to draw down the reservoir from the maximum flood control pool (spillway elevation 910.5 feet NGVD) is dependent on the maximum allowable discharge assumed from the outlets. Assuming that the discharge is limited to the all-year channel capacity of 540 cfs, the time required to draw down the reservoir to the conservation pool level of elevation 898.0 feet NGVD is approximately 29 days. To completely empty the reservoir from the spillway crest would require approximately 61 days. With one gate completely open, the time required to completely empty the reservoir from the spillway crest elevation would be reduced to approximately 33 days. With all gates

completely open, the time would be further reduced to approximately 24 days. Emergency drawdown curves for Clendening Lake are shown on **Plate No. 8-11**.

Should emergency drawdown become necessary, various procedures such as surveillance of the dam or notification of key personnel may be placed into effect, depending on the cause and its severity. Detailed information concerning these emergency actions can be found in the Flood Emergency Plan for Clendening Lake.

8-11. FREQUENCIES AND DURATIONS

a. Natural Discharge Frequency and Duration at the Outflow Gage. The natural discharge-frequency curve for the Stillwater Creek at the Clendening Lake outflow gage was developed on a regional basis in accordance with methods outlined in "Statistical Methods in Hydrology", by Leo R. Beard, dated January 1962, and Bulletin 17A, "Guidelines for Determining Flood Flow Frequency", published by the United States Water Resources Council and dated March 1976. A Log-Pearson Type III distribution was fitted to the annual event series at gaging stations in the Muskingum River Basin. This enabled generalized relationships to be derived which relate frequency curve characteristics, mean, standard deviation and skew to individual basin factors. This data were utilized to make flow frequency estimates for the project drainage area.

The curve derived by plotting probable maximum flow to be expected at the damsite against exceedence interval has been computed. Flow values for certain exceedence intervals from 1 year to 100 years are given on **Table No. 8-1**, next page.

Since 1937, flows in Stillwater Creek have been regulated by the Clendening Lake dam. A computer study of the duration of flow at the outflow gage was conducted using the U.S. Geological Survey record of flow past the gage for the period 1939 through 1978. Percent of total elapsed time during which the flow was at or above certain selected values was calculated. These flow values were then plotted against the percent of time as calculated for the full year and for each month to produce the Annual Flow Duration curve for Stillwater Creek at Tippecanoe.

TABLE NO. 8-1 FREQUENCY SUMMARY STILLWATER CREEK AT CLENDENING LAKE OUTFLOW GAGE ALL SEASONS - NATURAL		
<u>Exceedence Interval</u> (years)	<u>Natural Discharge</u> (cfs)	<u>Modified Discharge</u> (cfs)
100.....	3600.....	540
50.....	3200.....	540
20.....	2620.....	540
10.....	2200.....	540
5.....	1820.....	540
2.....	1360.....	540
1.....	1030.....	540

b. Pool Elevation Frequency and Duration. Peak pool elevations

for all significant rises experienced during actual operation of the Clendening Lake Project through 1986 have been analyzed using graphical frequency procedures. The annual curve derived from this study is shown on **Plate No. 8-1**, Frequency of Filling. Durations of selected pool elevations have been derived from actual pool elevations experienced at the Clendening Lake Project for the same period ending in 1986. Duration curves for average and maximum number of days per year derived from this study are shown on **Plate No. 8-2**, Duration of Filling. A frequency summary of Clendening Lake pool elevation deviations is shown below in **Table No. 8-2**, below.

TABLE NO. 8-2

**FREQUENCY SUMMARY
 CLENDENING LAKE POOL ELEVATION DEVIATION - ALL SEASONS**

<u>Exceedence Interval (years)</u>	<u>Elevation (feet NGVD)</u>
300.....	910.5
200.....	909.6
100.....	908.0
50.....	906.4
20.....	904.8
10.....	903.5
5.....	902.5
2.....	900.5
1.....	899.6

SECTION IX - WATER CONTROL MANAGEMENT

9-01. RESPONSIBILITIES AND ORGANIZATION

a. Corps of Engineers. General authorities for allocation and regulation of reservoir storage in projects owned and operated by the Corps of Engineers are contained in legislative authorization Acts and referenced project documents. These public laws and project documents usually contain provisions for development of water control plans, and appropriate revisions thereto, as shown on the Organization Chart **Plate No. 9-1**, under the discretionary authority of the Chief of Engineers. Some modifications in project operation are permitted under congressional enactments subsequent to original project authorization; regardless, Clendening Lake is fully owned and operated by the U.S. Government. The Huntington District, Corps of Engineers is the operating agency under administrative control of the Muskingum Area office within Operations and Readiness Division.

An organizational chart is shown on **Plate No. 9-1** for Water Control Management in the Tuscarawas - Muskingum River Basin. As shown on the chart, the Recreation-Resource Management Branch and the Muskingum River Area Office are responsible for supervision of the operation and maintenance of the dam and operations area at Clendening Lake. The Damtender (Resource Manager) at Clendening Dam regulates the Clendening Lake project in accordance with general instructions and Special Directives issued by the Water Management Section. Special Directives are issued and signed by the Chief, Water Management Section, for dissemination to the Muskingum area office as necessary to efficiently regulate the project for optimal water control management for all project purposes.

b. OCE Role in Water Control Activities. OCE will establish policies and guidelines applicable to all field offices and for such actions as are necessary to assure a reasonable degree of consistency in basic policies and practices in all Division areas. Assistance will be provided to field offices during emergencies and upon special request.

c. Great Lakes and Ohio River Division. The Division Engineer has primary responsibility and authority for direct action with respect to all phases of reservoir regulation, including: (a) basic policies, criteria, and concepts that determine operating plans; (b) technical evaluations; (c) field operation; and (d) review and approval of reservoir regulation plans and manuals and related activities. The Great Lakes and Ohio River Division Office (LRD) will coordinate water control management activities associated with inter-district, interdivision and interagency water resource needs. As established in accordance with ER 1110-2-1400, the Great Lakes and Ohio River Division Water Control Center is responsible for administration of the Division Engineer's policy for water control management.

d. Huntington District. The District Engineer has the primary responsibility for: (a) general management of reservoir regulation activities within their respective areas; (b) technical evaluations and performance of operations associated therewith; and (c) developing plans and manuals required for reservoirs and interrelated systems within their respective district area. The Water Resources Engineering Branch is the responsible element for all water control activities, which include the following reservoir project functions.

- (a) Flood Control;
- (b) Regulation of flows for water supply and water quality control;
- (c) Navigation stage regulation;
- (d) Hydropower;
- (e) Recreation;
- (f) Fish and Wildlife enhancement;
- (g) Alleviation of sediment and erosion problems affected by reservoirs.

Water control plans include coordinated reservoir regulation schedules for project/system operation and such additional provisions as may be required to collect, analyze and disseminate basic data, prepare detailed operating instructions, assure project safety and carry out regulation of projects in an appropriate manner. Water control plans will be developed utilizing objectives and specific provisions of project authorizing legislation and applicable Corps of Engineers reports. They will include any applicable authorities established after project construction. All water control plans will be prepared with appropriate consideration to all applicable congressional acts relating to operation of Federal facilities. Included are the Fish and Wildlife Coordination Act (P.L. 85-624), Federal Water Project Recreation Act-Uniform Policies (P.L. 89-72), National Environmental Policy Act of 1969 (P.L. 91-190), and Clean Water Act of 1977 (P.L. 95-217). Thorough analysis and testing studies will be made as necessary to establish the optimum water control plans possible within prevailing constraints.

The Water Resources Engineering Branch is further delegated the responsibility to coordinate the operation of specific projects with Federal and State agencies, local entities, and the general public. The Division Engineer, ATTN: CELRD-EC-W, is advised, as soon as possible, of any coordination activities which may require a study, public hearing, or revision in operating plans. Districts are required to alert the Division Engineer, ATTN: CELRD-EC-W, of any significant deviations from routine regulation plans. The communication mode for the advisory is commensurate with the urgency of the situation and is transmitted before the district implements a plan of action.

During normal operations, non-flood periods, water control management activity is accomplished by personnel of the Water Management Section of the Water Resources Engineering Branch. During flood conditions and other emergencies, assistance of other Construction-Engineering Division personnel may be required to maintain effective water control management within the Huntington District. The area affected and magnitude of the flood determines the number of people temporarily assigned to each major river basin or sub-basin for the emergency.

During normal operations, personnel of the Water Management Section of the Water Resources Engineering Branch are involved in the following

activities pertaining to water control management as shown on **Plate No. 9-1**:

(a) Routine regulation of the lakes and dissemination of pertinent data.

(b) Investigations and refinement of regulation procedures such as analysis of past floods, channel investigations, improvement of forecasting, and planning programs with other agencies.

(c) Training personnel in flood control duties with visits to projects and instructing Water Resources Engineering Branch personnel from other sections.

(d) Development and application of mathematical modeling to complex reservoir systems.

(e) Operation of the Water Resources Engineering Branch hydrologic data collection and water control management system, including computers and field equipment.

(f) Developing and conducting effective public information programs to inform and educate the public regarding Corps of Engineers water control management activities.

(g) Preparing and submitting reports on lake regulations such as daily reports, weekly reports, monthly reports, annual reports, weekly briefings, and post-flood reports.

(h) Preparing and updating water control manuals for individual projects and master manuals for basins.

During FLOOD EMERGENCIES, Water Resources Engineering Branch personnel are responsible for the following activities in regard to water control management as shown on **Plate No. 9-2**, in two sheets:

(a) Evaluation and dissemination of current and forecast hydrologic, hydraulic and meteorologic data.

(b) Presentation of storm and flood analysis to the District Engineer and pertinent staff members.

(c) Providing liaison personnel to support Emergency Operations Center when it is operational.

(d) Regulation of all projects and systems in accordance with approved plans.

(e) Furnishing information to others such as reports to higher authority, status to Emergency Operations Center and data to Public Affairs Office.

During a FLOOD EMERGENCY SITUATION the lines of communication between the various office elements are shown on **Plate No. 9-2**. Details and responsibilities of other elements are indicated in the overall district plan in the Emergency Operations Center Plan and ER 500-1-1, ER 500-2-1 and all annexes to these two ER's.

The National Weather Service and project personnel are provided with a list of names of Water Resources Engineering Branch personnel and home telephone numbers with instructions to contact them during off-duty

hours if unusual conditions occur or a project is in a particular reporting schedule. During emergency conditions or flood regulation, Water Resources Engineering Branch staffs are available from 18 to 24 hours daily, depending on the magnitude of a particular event. At each project, including Clendening Lake, responsible personnel will be on duty or on call at all times.

9-02. INTERAGENCY COORDINATION AND COOPERATION

The Huntington District also works in cooperation with other Federal, State, local and private organizations and agencies. These relationships are described in detail in the following paragraphs and illustrated in **Plate No. 9-3**.

a. Local Press and Corps Bulletins. Huntington District Office and the National Weather Service, coordinate in forecasting flood stages. Local press is provided with information of flood forecasts as furnished by the National Weather Services (officially responsible for issuing flood warnings). This information will be supplemented by the Corps with available information on observed conditions and with technical advice to enable local interests, within the limits of their capabilities, to obtain optimum flood protection, and to perform rescue and relief functions.

The Public Affairs Office in the Huntington District Office releases various other items to the press for public dissemination. Some of these are in the public interest such as drawdown announcements or notification of a change in or opening of a new facility or service at a reservoir. Some releases are to enlist public cooperation and some, such as reports of flood damages saved by regulation of certain reservoirs, are to inform the public of the benefits derived from Corps-built projects. Many such varied articles are printed in Castle Comments, the District newspaper; and Engineer Update, the newspaper from the Corps of Engineers. Both are unofficial monthly publications for Corps of Engineers employees and retirees of all ages.

b. National Weather Service. An agreement between the National Weather Service (NWS) and The Corps of Engineers provides for collection and dissemination of current precipitation data for the Ohio River Basin. By joint agreement, the NWS installs, maintains and operates all stations in the Ohio River Network, except those operated by the Corps of Engineer personnel at flood-control and navigation projects. Where there is a mutual need for the data, station costs are shared by both the NWS and the Corps of Engineers. Costs of stations required for reservoir regulation are borne entirely by the Corps of Engineers. In either case, an annual transfer of funds from the Corps of Engineers to NWS is made to cover the required expenditures. As described in paragraph 6-02b, NWS provides a range of tributary stage information and forecasts. The Corps reciprocates, providing NWS with all precipitation, snow cover, and stage information from reservoir and other reports, pool level and outflow forecasts, and depth reports from the District Snow Cover Reconnaissance.

c. U.S. Geological Survey. The Cooperative Stream Gaging Program was established about 1940 through cooperative arrangements between the Corps of Engineers and the USGS in order that sufficient stream flow water would be available to meet special needs in

connection with the Corps water resources responsibilities. This is in keeping with the Chief of Engineers policy of fully utilizing the facilities and services of other Federal Agencies in obtaining many types of basic data. Accordingly, arrangements were made for the Geological Survey to operate specific stations for the Corps on an advance of funds basis. Although the Corps of Engineers requires the basic data, many other Federal, State, and private agencies and individuals interested use the water data. The data are published by the survey assuring maximum availability and use of all data.

The annual program is formulated by the Water Resources Engineering Branch in collaboration with appropriate District Chiefs of the Geological Survey. The Corps of Engineers and the local representative of the U.S. Geological Survey determine the necessary stations to provide the data for publication and the Corps is requested to furnish an estimate of the costs of installing and/or operating each station. The District Engineer forwards the selected program through the Division Engineer to the Chief of Engineers. Any supplemental instructions of a current nature necessary in connection with preparation of the report are issued annually by the Chief of Engineers.

The Geological Survey coordination and cooperation with the Corps, described in paragraph 5-01, provides the Water Management Section with a system for obtaining reliable stage and flow information, which is necessary for efficient water control management.

d. Ohio Department of Natural Resources. The Huntington District Water Management Section cooperates fully with the Ohio Department of Natural Resources about fish and wildlife enhancement in the Ohio lakes and downstream areas, by making special efforts to maintain constant pool elevations during April, May, and June for spawning benefit. Additional coordination is used for proper timing of spring filling and fall drawdown, and probable height of both lake level manipulations during flooding and expected project outflow.

The Ohio Department of Natural Resources maintains an Office of Corps Liaison for the purpose of coordinating special releases from Corps Lakes for training or other purposes. This office receives all requests for special regulation and, after examining the request and appending to it any ODNR comments, sends the request to the District Office. Using the Corps based guidance policies and criteria a determination is then made, and this decision is then sent back to the ODNR to coordinate with the organization making the request.

Functional agreements, meetings, and contacts with various divisions of the Department of Natural Resources are discussed below. They are important to operation of the project in accordance with project purposes and with the recommendations of the Ohio Department of Natural Resources and the U.S. Fish and Wildlife Service.

The Ohio Division of Forestry at Columbus, all project lake Corps Personnel, and project lake state park personnel cooperate in fire-fighting activities to suppress fires that threaten or are burning on project lands. Project personnel cooperate by taking training in fire suppression techniques, reporting such fires to the ODNR District Forester, fighting the fires before State personnel arrive and by assisting their suppression efforts after arrival.

The Parks and Recreation Division will enforce the Boating safety and water regulations, while hunting and fishing licensure procedure

enforcement is by the Division of Wildlife. There is frequent day-to-day contact between project personnel and Ohio Department of Natural Resources personnel through much of the year.

e. Other State, Federal, Local or Private Agencies. The Corps of Engineers receives requests for information, aid, or cooperation from many parties, groups, and private interests or businesses presently involved with Clendening Lake. All legitimate responsible requests from Federal, State, local, or private organizations or from groups that coordinate with ODNR receive appropriate attention and consideration. Accuracy of information transmitted and the proper level or amount of aid or cooperation given is commanded by District policy. Huntington District reacts quickly in disaster situations, allocating material and man power when needs are in Corps areas of responsibility and expertise.

In certain cases, such as potential downstream flooding concerns or emergency complications involving regulation of Clendening Lake, the District Emergency Operations Manager coordinates with the Ohio Disaster Services Agency. An example of cooperation with a State entity is an occasion when the Corps studies damages and reconstruction costs due to a flood or other disaster for the office of the Governor to use in applying for Federal assistance.

In accord with the Corps of Engineers statutory responsibility for operation of its reservoirs in the public interest, the Great Lakes and Ohio River Division Engineer organized the Reservoir Operation Coordinating Group for the Ohio River Basin as a vehicle for perceiving, interpreting, and prioritizing that interest. The Group is composed of the twelve basin states, the Tennessee Valley Authority, six Federal Agencies, and two regional commissions, which are Ohio River Oriented. The Group meets three times yearly and provides a mechanism for a two-way communication through various levels of government and among various agencies of government and other organizations, which serve the public. Meetings of the Group have the stated mission of bringing focus to the public's varied interests in reservoir regulation and accordingly perfecting that regulation to the maximum extent possible.

Water Resources Engineering Branch personnel sends to each meeting a report which summarizes hydrologic and meteorologic situations in the district for the preceding three month or six month period highlighting pertinent events, flood control activity, and special operations by each project.

No local or state agency has funding or operational responsibilities in the Huntington District multipurpose reservoirs except in leased recreational areas. The State of Ohio constitutionally holds in trust all wild animal life in the state on both public and private lands, and all aquatic life in public waters. The State Department of Natural Resources, as mandated by State Code, has the responsibility for conservation of fish and wildlife and for boating safety at the project lakes. The Game Protection Division of the Department of Natural Resources enforces hunting regulations and licenses on the reservoir lands. The State has undertaken fish management at the project lakes and the Corps of Engineers cooperates in the lake level manipulation and maintenance of downstream flow requirements to enhance fisheries management.

The Corps of Engineers is required by the Fish and Wildlife Coordination Act (48 Stat. as amended) to coordinate all plans

affecting Fish and Wildlife with the U.S. Fish and Wildlife Service. The service is required to present the plans to the relevant State Agency, in this case, the Ohio Department of Natural Resources, for their comments and recommendations. The Service then presents a combined report to the Corps including its comments and recommendations and those of the Ohio Department of Natural Resources.

9-03. INTERAGENCY AGREEMENTS, MEETINGS AND ORGANIZATIONS

Agreements among the Corps of Engineers, the U.S. Geological Survey, and the National Weather Service are mentioned and outlined in paragraphs 6-02a and b. An annual meeting is held with each of the State branches of the Geological Survey cooperating in the Stream Gaging Program. The Corps and Weather Service mutually agree upon scheduling of meetings concerning the Ohio River Network on an as-needed basis.

In the interest of fire protection for visitors, employees, property and animal and plant life, the District executed a memorandum of understanding covering all Corps reservoir projects in Ohio with the Ohio Department of Natural Resources to be administered by the Division of Forestry. The understanding includes cooperative warning and suppression of fires on or threatening Corps owned lands, Ohio Department of Natural Resources maintenance of a standard cache of fire-fighting tools at the project, and payment by the Corps of extinguishment costs incurred by the Ohio Department of Natural Resources.

The Great Lakes and Ohio River Division, Water Management Division holds a quarterly meeting of the Reservoir Operations Coordinating Group. The meeting is normally attended by representatives of Federal, Regional, and State agencies and commissions; along with Corps representatives of District and Division reservoir regulation elements. The purpose of the meeting is to exchange information and views on regional water recourse concerns.

9-04. COMMISSIONS, RIVER AUTHORITIES, COMPACTS, AND COMMITTEES

a. Ohio River Basin Commission(ORBC). This commission has an active interest in the operation of Clendening Lake and acts in a consultative capacity to both governmental and private interests in the basin. The commission members are representatives of Federal and State leaders in Water Resources. The commissions purpose is to provide a forum for the Ohio River border states to study, discuss, and develop regional policies and positions on common interstate issues concerning water and related land issues.

b. Ohio River Valley Water Sanitation Commission(ORVSANCO). This commission, created in 1948, coordinates the water quality programs of member states, and promulgates regulations to prevent and mitigate water quality problems on the Ohio River and its tributaries. The states of New York, Ohio, Indiana, Illinois, Pennsylvania, West Virginia, Kentucky, and Virginia are represented on this commission.

c. Ohio Fish and Wildlife Service(PFBC). This commission has interest in water related issues as they affect fishery resources and boating opportunities in the state.

d. Ohio Department of Natural Resources(ODNR). Through its

several divisions, the ODNR regulates water appropriation and all activities with direct impact on public streams and lakes in the state of Ohio.

e. District Drought Monitoring Committee(DDMC). This is an existing committee consisting of Huntington District Corps of Engineers personnel from the Planning, Operation and Readiness, and Engineering and Construction divisions; the Office of Council; and the Public Affairs Office. The purpose of this committee is to review guidelines, develop and implement functional drought contingency plans, and to keep the DDMC informed on drought status and drought related topics and issues.

f. Corps Drought Management Committee(CDMC). The CDMC is composed of personnel from the Planning, Operation and Readiness, and Engineering and Construction divisions; the Office of Counsel; and the Public Affairs Office. The purpose of the committee is to represent the broad range of Federal interests and to establish and direct the water management policy for the Huntington District during a drought. Where possible, the Chief of the Engineering - Construction Division uses guidelines from this committee in developing and justifying deviations from approved water management plans and procedures.

g. Inter-agency Drought Management Committee(IDMC). The IDMC is composed of local, state, and Federal agency directors that have the authority to represent all user water needs within the Muskingum River Basin. Federal members include the Huntington District Commander who serves as the Chairmen, and agency heads or their designees from the Federal Emergency Management Committee Agency, U.S. Fish and Wild Life Service, Environmental Protection Agency, National Weather Service, U.S. Geological Survey, and Soil Conservation Service. State members include department heads or their designees from the Ohio Department of Environmental Protection and the Ohio Emergency Management Agency. Local members include representatives from the area counties. The purpose of the committee is to review the status of Districts lake storage and operations, review drought related water needs and requests, develop proposed action plans for meeting consolidated and coordinated user needs, and set priorities and define actions on these needs.

9-05. HUNTINGTON DISTRICT REPORTS

Table No. 9-1 end of section contains a listing of the various Periodic and Special reports provided by the District Water Management Section.

a. Periodic.

(1) Daily. Districts are required to report current hydrologic data daily as prescribed by the Division Office. A daily report is prepared five days per week by the Water Management Section of the Water Resources Engineering Branch Monday through Friday and on Saturdays, Sundays and holidays. It is prepared as detailed in sub-section 6-03 and inserted into a computer file. After review, the report is sent over a leased line to the Great Lakes and Ohio River Division water control system. The transmission includes morning lake elevation, rate and temperature of outflow, and 3-day forecast of lake and outflow for all reservoir projects Monday thru Friday. Ohio River morning stages and 24-hour rainfall, morning stage and flow and 5-day flow forecast for Ohio River tributary gage points complete the

transmission and the report. The report items are prepared in accordance with ORDER 1110-2-20, CHORD-ED-W lt, 10 Jul 69, CHORD-ED-W lt, 23 Jan 67, and ORDER 1110-2-17.

Daily or more frequent briefings of the District Engineer and Chief Engineer containing pertinent hydrologic and meteorologic information are made during flood or other emergencies.

In carrying out water control activities, Corps of Engineers personnel must recognize and observe the legal responsibility of the National Weather Service (NWS) and the National Oceanic and Atmospheric Administration (NOAA) for issuing weather forecasts and flood warnings, including river discharges and stages. River forecasts prepared by the Corps of Engineers in the execution of its responsibilities should not be released to the general public, unless the NWS is willing to make the release or agrees to such dissemination. However, release to interested parties of factual information on current storms or river conditions and properly quoted NWS forecasts are permissible. District offices are encouraged to provide assistance to communities and individuals regarding the impact of forecasted floods. Typical advice would be to provide approximate water surface elevations at locations upstream and downstream of the NWS forecasting stream gages. Announcement of anticipated changes in reservoir release rates as far in advance as possible to the general public is the responsibility of Corps of Engineers water control managers for projects under their jurisdiction.

(2) Weekly. Each week a list of 24-hour reservoir effects at tributary gage points is transmitted to LRD. The list, which gives flows in cfs held out from or added to the natural flow, shows the data for an entire week ending with the current week. All of the key gage points are reported for the Muskingum and Ohio River Basins. The main stem points are located at New Philadelphia, Newcomerstown, Coshocton, Zanesville, and Marietta, Ohio.

During any flood, drought or other emergency involving reservoirs, the Ohio River or other streams in the District, the Water resources Engineering Branch provides all available information to the District Engineer, Chief of Engineers and interested elements as frequently as necessary.

(3) Monthly. Engineer Regulation No. 1110-2-240, dated 8 October 1982 requires that a monthly record of reservoirs operated by the District be promptly prepared by the Water Management Section according to 33 CFR 208.11 and maintained in tabular form readily available for transmittal to the Chief of Engineers or others on request.

(4) Quarterly Reservoir Operations. Each District provides a quarterly review of meteorological influences and water control management activities to each of the four yearly meetings of the Reservoir Operations Coordinating Group. Huntington District personnel of the Water Management Section summarize and compare weather experienced with long-term normals and actual streamflows to mean annual values. They describe seasonal features of operation such as spring filling, summer outflow temperature control or fall drawdown, frozen lakes and effect of river ice on navigation, in addition to any significant flood control operations and damages prevented.

(5) Annual. The Division Engineer is required by ORDR

1110-2-27 and CEORD-ED-W Ltr, 30 September 1977 to submit to OCE for approval an annual report on reservoir regulation activities of significance during the fiscal year ending and programs proposed for the year following. This report summarizes the water control activities throughout the Ohio River Basin. Therefore district input is mandatory. The following documentation of district programs and activities is requested by 1 November of each year:

(a) A brief summary highlighting the significant accomplishments attributed to each reservoir during the preceding fiscal year.

(b) Reservoir regulation manual submission schedule.

(c) Concise reports on major accomplishments concerning personnel, training, model application, ADP use, data reporting and analysis, and general improvements in reservoir regulation activities.

By Executive Order 12088, the President ordered the head of each Executive Agency to be responsible for ensuring that all necessary actions are taken for prevention, control, and abatement of environmental pollution with respect to Federal facilities and activities under control of the agency. An annual Division Water Quality report is required by ORDR-2-26. The report is submitted in two parts. The first part addresses the divisions Water Quality management plan while the second part presents specific project information. A major objective of this report is to summarize information pertinent to overall water management responsibilities. An Annual Water Quality Report by Districts to LRD includes narrative and tabular summaries of water quality activities and conditions in the Districts. The District report contains a synopsis of activities, specific cases of interest, improvements during the year, and plans for future emphasis. The tabular portion includes an overview of water quality activities, an overview of water quality conditions, specific water quality control actions in coordination with the Water Management Section, aimed at identification or solution of problems and problems requiring special studies with schedules for executing the studies. The annual water quality report is submitted by 1 December of each year.

b. Special Reports.

(1) Reports on Reservoir Operations during Flood Emergencies. Information on reservoir operations to be included in reports submitted to the Chief of Engineers during flood emergencies in accordance with ER 500-1-1 include rate of inflow and outflow in cfs, reservoir levels, predicted maximum level and anticipated date, and percent of flood control storage utilized to date. Maximum use should be made of computerized communication facilities in reporting project status to DAEN-CWO-E/CWE-HY in accordance with the requirements of ER 500-1-1.

(2) Post-Flood Report of Reservoir Effects. Information on the operation of the affected reservoirs is gathered in accordance with ER 500-1-1. This report provides details on antecedent meteorologic and hydrologic conditions, description of the performance of the dam and appurtenant works, detailed analysis of the operating procedures, and effects of reservoir operation on Stillwater Creek, Tuscarawas, Muskingum, and the Ohio River. Reservoir effects include evaluation of the stage reductions at key stations, estimates of damages prevented by the projects, and precipitation maps will be included in the post-flood reports required by ER 500-1-1. Conclusions

are discussed with regard to adequacy of operating technique, performance of structures, and benefits derived from operations during the flood. The report usually shows tabular and graphic data used to calculate stage reductions at the following gaging stations pertinent to Clendening Lake: Tuscarawas River at New Philadelphia and Newcomerstown, Muskingum River at Coshocton, Zanesville, and Marietta, and Ohio River at Marietta. The outline of a typical post flood report is given below.

- I- Authority, Purpose And Scope
- II- Basin Description
 - Basin Flood Control works
 - Impact of Flood
- III- General Precipitation
 - Storms and Reservoirs
- IV- Damages and Flooding
- V- Antecedent Rainfall
 - Storm Rainfall and Runoff
- VI- General Method of Operation
 - Emergency and Standing Instructions
 - Flood Control Operations during Storms
 - Special Operations
 - Operations during Release Period
 - Results of Operation
 - Flood Damages Eliminated
- VII- Computer Programs Utilized
 - Special Flood Activity

(3) Fiscal year budget requests. Fiscal year budget requests for water control management activities are prepared and submitted to the Office of the Chief of Engineers in accordance with requirements established in Engineer Circular on Annual Budget Requests for Civil Works Activities. The total annual costs of all activities and facilities that support the water control functions (excluding physical operation of projects, but including flood control and regulation of navigation projects subject to 33 CFR 208.11) are reported. Information on the Water Control Data Systems and associated Communications Category of the Plant Replacement and Improvement Program is submitted with the annual budget. Reporting is in accordance with an Engineer Regulation and the annual Engineer Circular on Civil Works Operations and Maintenance, General Program.

(4) The Chief of Engineers. The Chief of Engineers and staff require information to respond to inquiries from members of Congress and others regarding runoff potentials. Therefore, the Division Engineer submits a snowmelt runoff and flood potential letter report covering the snow accumulation and runoff period, beginning generally in February and continuing monthly, until the potential no longer exists, if necessary. Dispatch of supplemental reports is determined by the urgencies of situations as they occur. The reports are forwarded as soon as hydrologic data are available, but not later than the 10th of the month. For further information on reporting refer to ER 500-1-1.

(5) Major droughts. During major droughts or extreme low-flow conditions, narrative summaries of the situation should be furnished to alert the Chief of Engineers regarding the possibility of serious runoff deficiencies that are likely to precipitate actions associated with Corps of Engineers reservoirs.

(6) Master Plans. Division water control managers will develop Master plans for water control data systems and significant revisions thereto. They are submitted to HQDA (DAEN-CWE-HY) Washington, DC 20314, for review and approval of engineering aspects. Engineering approval does not constitute funding approval. After engineering approval is obtained, equipment in the master plan is eligible for consideration in the funding processes described in ER 1125-2-301 and Engineering Circulars on the Annual Budget Request for Civil Works Activities. Master plans are maintained current and are updated as necessary to meet needs.

Modified master plans are submitted by 1 February if revisions are required to include equipment not previously approved or for changes in scope or approach. Submittal by the February date allows adequate time for OCE review and approval prior to annual budget submittals.

(7) Miscellaneous. Any additional or pertinent reports required from higher authority will be promptly compiled and transmitted.

TABLE NO. 9-1

HUNTINGTON DISTRICT REPORTS
BY
WATER RESOURCES ENGINEERING BRANCH

PERIODIC REPORTS - Computer reports keyed to forms formerly completed by hand as follows:

Daily - Computer reports of observed and forecast stages and flows including:

-Morning reservoir pool elevation, outflow, outflow temperature and three-day pool and outflow forecast.

-24-hour rainfall, morning stage, flow and five-day flow forecasts at Ohio River tributary gage points.

Weekly Reservoir effects at Ohio River tributary gage points.

Monthly Records of District reservoirs available on request.

Annually Summary of significant reservoir regulation activities for the year and of programs proposed for the following year.

SPECIAL REPORTS:

Daily or more frequent briefing of District Engineer and Chief Engineer during flood or other emergencies containing hydrologic, meteorologic, and operational information, when and as requested.

Information relevant to flooded area or situation to the Emergency Operations Center (when functioning) such as pertinent data about the area, copies of reservoir morning and extra reports, relay of any verbal reports, relevant NWS zone forecasts and special bulletins, and computer generated isohyetal maps of the District.

Reports on reservoir operations to OCE during flood emergencies including inflow, outflow, pool elevation, predicted crest, and maximum storage utilization to date.

Post-flood reports.

Budget requests for water control management activities to OCE.

Snowmelt runoff and flood potential reports to OCE.

Narrative summaries of major drought or low-flow conditions likely to require special regulation of District reservoirs.

Master plans for water control data systems and significant revisions thereto are submitted to HQDA (DAEN-CWE-HY) Washington, DC 20314, for review and approval of engineering.

TABLE NO. 4-1

CLIMATIC SUMMARY - CLENDENING LAKE & VICINITY

Condition	Station	Jan	Feb	Mar	Apr	May	Jun	Jul	Aug	Sep	Oct	Nov	Dec	Annual
Normal Monthly and Annual Precipitation (Inches)	Clendening Lk.*	2.75	2.43	3.71	3.71	3.97	3.96	4.29	4.10	3.12	2.58	2.52	2.69	39.83
	Cadiz	2.77	2.29	3.36	3.51	3.85	3.81	4.29	3.82	2.72	2.63	2.59	2.59	38.23
	Piedmont Lake	2.55	2.29	3.47	3.48	3.76	3.56	4.14	3.68	2.78	2.39	2.48	2.52	37.10
Normal Monthly And Annual Temperature (°F)	Clendening Lk.*	Data not taken at this station												
	Cadiz	29.1	30.0	39.7	51.2	60.9	68.9	72.4	71.5	65.6	54.3	42.6	32.1	51.4
	Piedmont Lake	Data not taken at this station												
Normal Monthly And Annual Snowfall (Inches)	Clendening Lk.*	10.3	7.9	6.2	0.7						0.1	2.7	6.6	34.5
	Cadiz	Data not taken at this station												
	Piedmont Lake	Data not taken at this station												

* Station is within Clendening Lake drainage basin

Period for climatological normals: 1951 - 1980 for precipitation and temperature data; snowfall data at Clendening Lake is for 40 years through 1978. (Snowfall records at Clendening Lake since 1978 are incomplete).

TABLE NO. 5-1

**CLENDENING LAKE
BRUSHY FORK-STILLWATER CREEK BASIN STREAM GAGING NETWORK - PERTINENT DATA**

Stream and Station	Zero Gage Elevation Feet NGVD	Drainage Area Sq. Mi.	Date Established Month/Year	Existing Station Facilities	Method of Obtaining Data
Brushy Fork of Stillwater Ck at Clendening Lk	862.0	69.3	Jun 1938	Manometer, Stevens continuous recorder, called strip chart, Data Collection Platform (shortened to DCP), hydro-logger. Other gages include a staff.	Project personnel view strip chart and include readings in regular and extra reports. DCP transmits via satellite to downlink and data disseminated to water control system.
Brushy Fork below Clendening Lk	853.0	69.3	Nov 1937	Staff gage in stilling basin.	Project personnel view staff gage and include readings in regular and extra reports.
Stillwater Ck at Tippecanoe, OH	849.0	282	Oct 1938	Analog-to-digital recorder, called ADR, strip chart, Voice DCP, and tipping bucket precipitation gage. Other gages include an electric reference tape, called tape, and a wire weight.	Project personnel call DCP and include readings in regular and extras reports. DCP transmits via satellite to downlink and data retrieved by water control system.
Stillwater Ck at Uhrichsville, OH	839.37	367	Jul 1922	ADR, strip chart, Voice DCP. Other gages include a tape and tipping bucket precipitation gage.	Area Office personnel call DCP and include readings in regular & extra reports. DCP transmits via satellite to downlink and data retrieved by water control system.
Little Stillwater Ck below Tappan Lk	861.0	71.1	Oct 1968	Manometer, analog-to-digital recorder, called ADR, strip chart, DCP, hydrologger. No other gages.	Project personnel view remoted readout and include readings in regular and extra reports.
Stillwater Ck at Piedmont, OH	872.0	122	Oct 1938	Strip chart and tape, DCP, hydrologger.	Project personnel view remoted readout and include readings in regular and extra reports.

TABLE NO. 5-2

PRECIPITATION STATIONS IN AND NEAR
 CLENDENING LAKE BASIN - PERTINENT DATA

<u>Record From</u>	<u>Station</u>	<u>Equipment</u>	<u>Method Obtaining Data</u>	<u>Reporting Criteria</u>
4/38	Clendening Lk	8-inch SRG	Project personnel read gage and include reading in regular and extra reports. Rainfall only via telephone to Area Office.	Daily at 0730 amount of precipitation collected in previous 24 hours. Extra reports at 1330 if 0.5 inch or more collected after 0730.
9/30	Cadiz	8-inch SRG Tipping bucket and Data Collec- tion Platform	Observer calls Muskingum Area Office about 0730 hours. Additional reports (including week-ends and holidays) also called in to Area Office personnel or to office recorder.	0.5 inch precipitation collected in 24 hours prior to 0700 or in 12 hours prior to 1900. Any subsequent precipitation reported each 12 hours until told to stop or after first report of zero. Each report is of precipitation since previous 0700 reading. DCP data collection interval 60 minutes.
4/38	Tappan Lk	8-inch SRG	Project personnel read gage and include reading in morning report. Extra reports by telephone to Area Office.	Daily at 0730 amount of precipitation collected in previous 24 hours. Extra at 1330 if 0.5 inch or more collected after 0730.
2/38	Piedmont Lk	Tipping bucket gage with heater and Data Collec- tion Platform	Platform transmits via satellite to receiver each 4 hours. Water control system retrieves data.	Data collection interval 60 minutes.
4/38	Piedmont Lk	8-inch SRG	Project personnel read gage and include reading in regular and extra reports. Rainfall only via telephone to Area Office.	Daily at 0730 amount of precipitation collected in previous 24 hours. Extra reports at 1330 if 0.5 inch or more collected after 0730.

TABLE NO. 6-1

CLENDENING LAKE

BRUSHY FORK-STILLWATER CREEK BASIN STREAM GAGING NETWORK - PERTINENT DATA

<u>Stream and Station</u>	<u>Zero Gage Elevation Feet msl</u>	<u>Drainage Area Sq. Mi.</u>	<u>Date Established Month/Year</u>	<u>Existing Station Facilities</u>	<u>Method of Obtaining Data</u>
Brushy Fork of Stillwater Creek at Clendening Lake	862.0	69.3	Jun 1938	Manometer, Stevens continuous recorder, called strip chart. Data Collection Platform (shortened to DCP). Other gages include a staff.	Project personnel view scrip chare and Include readings in regular and extra reports. DCP transmits via satellite to downlink and data disseminated to water control system.
Brushy Fork below Clendening Lake	853.0	69.3	Nov 1937	Staff gage in stilling basin.	Project personnel view staff gage and include readings in regular and extra reports.
Stillwater Creek at Tippecanoe, Ohio	849.0	282	Oct 1938	Analog-to-digital recorder, called ADR, strip chare. Voice DCP, and tipping bucket precipitation gage. Other gages include an electric reference Cape, called cape, and a wire weight.	Project personnel call DCP and include readings in regular and extra reports. DCP transmits via satellite Co downlink and data retrieved by water control system.
Stillwater Creek at Uhrichsville, Ohio	839.37	367	Jul 1922	ADR, scrip chart. Voice DCP. Other gages include a cape and tipping bucket precipitation gage.	Area Office personnel call DCP and include readings in regular and extra reports. DCP transmits via satellite to downlink and data retrieved by water control system.
Little Stillwater Creek below Tappan Lake	861.0	71.1	Oct 1968	Manometer, analog-co-digital recorder, called ADR, scrip chare, DCP. No ocher gages.	Project personnel view remoted readout and include readings in regular and extra reports.
Stillwater Creek at Piedmont, Ohio	872.0	122	Oct 1938	Strip chart and tape, DCP.	Project personnel view remoted readout and include readings in regular and extra reports.

TABLE NO. 6-2

PRECIPITATION STATIONS IN AND NEAR
 CLENDENING LAKE BASIN - PERTINENT DATA

<u>Record From</u>	<u>Station</u>	<u>Equipment</u>	<u>Method of Obtaining Data</u>	<u>Reporting Criteria</u>
4/38	Clendening Lake	8-inch SRG	Project personnel read gage and include reading in regular and extra reports. Rainfall only via telephone to Area Office.	Daily at 0730 amount of precipitation collected in previous 24 hours. Extra reports at 1330 if 0.5 inch or more collected after 0730.
9/30	Cadiz	8-inch SRG	Observer calls Muskingum Area Office about 0730 hours. Additional reports (including weekends and holidays) also called in to Area Office personnel or to office recorder.	0.5 inch precipitation collected in 24 hours prior to 0700 or in 12 hours prior to 1900. Any subsequent precipitation reported each 12 hours until cold Co stop or after first report of zero. Each report is of precipitation since previous 0700 reading.
4/38	Tappan Lake	8-inch SRG	Project personnel read gage and include reading in morning report. Extra reports by telephone to Area Office.	Daily at 0730 amount of precipitation collected in previous 24 hours. Extra at 1330 if 0.5 inch or more collected after 0730.
2/38	Piedmont Lake	Tipping bucket gage with heater and Data Collection Platform.	Platform transmits via satellite to receiver each 4 hours. Water control system retrieves data.	Data collection interval 60 minutes.

TABLE NO. 6-2(CONT'D)

PRECIPITATION STATIONS IN AND NEAR
 CLENDENING LAKE BASIN - PERTINENT DATA

<u>Record From</u>	<u>Station</u>	<u>Equipment</u>	<u>Method of Obtaining Data</u>	<u>Reporting Criteria</u>
4/38	Piedmont Lake	8-inch SRG	Project personnel read gage and include reading in regular and extra reports. Rainfall only via telephone to Area Office.	Daily at 0730 amount of precipitation collected in previous 24 hours. Extra reports at 1330 if 0.5 inch or more collected after 0730.
8/39	Barnesville	8-inch SRG	Observer calls Muskingum Area Office about 0730 hours. Additional reports (including weekends and holidays) also called to Area Office personnel or to office recorder.	0.5 inch precipitation collected in 24 hours prior to 0700 or in 12 hours prior to 1900. Any subsequent precipitation reported each 12 hours until told to stop or after first report of zero. Each report is of precipitation since previous 0700 reading.

CLENDENING LAKE

BRUSHY FORK OF STILLWATER CREEK-TUSCARAWAS RIVER BASIN

PERTINENT DATA

LOCATION

The dam is located in Harrison County, Ohio, on Brushy Fork of Stillwater Creek of the Tuscarawas River, a tributary of the Muskingum River. The dam is located 184.4 miles above the mouth of the Muskingum River.

TYPE OF PROJECT

Multi-purpose; flood control, recreation, fish and wildlife conservation.

AUTHORITY

The Muskingum Watershed Conservancy District was created on 3 June 1933 for the purpose of developing a plan for flood control, water conservation, and water use in the Muskingum River Basin. A general plan was prepared, and application for approval of the project system and a request for financial cooperation was filed with the Federal Emergency Administration of Public Works in August 1933. The Public Works Administration approved the project system in December 1933 and allocated funds to the Corps of Engineers in financing the construction of the projects.

The Corps of Engineers initiated investigations following the execution of a contract between the United States of America and the Muskingum Watershed Conservancy District on 29 March 1934. The official plan was proposed by the COE and was approved by the Conservancy District on 19 November 1934.

The Flood Control Act, approved 11 August 1939, contained a provision that the dams and reservoirs be included in the Comprehensive Flood Control Plan for the Ohio River Basin. Operation and maintenance of the 14-reservoir system (which includes Clendening Lake) have been the responsibility of the Corps of Engineers since that date.

PURPOSES

The project was initially authorized for reduction of flood heights on the Tuscarawas and Muskingum Rivers. As noted in the paragraph above, the project was later included in the Comprehensive Ohio River Flood Control Plan. In addition to flood control, other major purposes are general recreation and fish and wildlife conservation.

CLENDENING LAKE

PERTINENT DATA (Cont'd)

DRAINAGE AREAS (Square Miles)

Brushy Fork at Clendening Lake.....	69.3
Brushy Fork at Mouth.....	70.0
Stillwater Creek above Brushy Fork.....	212
Stillwater Creek at Tippecanoe.....	282
Stillwater Creek at Uhrichsville.....	367
Stillwater Creek at Mouth.....	485
Tuscarawas River above Stillwater Creek.....	1,870
Tuscarawas River at Mouth.....	2,596
Muskingum River at Mouth.....	8,051

STREAMFLOW DATA (Cubic feet per second)

Average annual flow just below Damsite.....	80
Maximum peak discharge at Damsite.....	3,650
Minimum discharge just below Damsite.....	zero

RESERVOIR DATA

Elevation (Feet above NGVD)

Streambed at Damsite.....	858
Minimum or Winter Pool.....	*893
Seasonal or Summer Pool.....	898
Flood Control Pool.....	910.5
Spillway Design Flood Crest.....	923.5

<u>Capacities</u>	<u>Acre-Feet</u>		<u>Inches-Runoff</u>	
	<u>Net</u>	<u>Gross</u>	<u>Net</u>	<u>Gross</u>
Minimum (year-round) Pool.....	*18,500	18,500	5.0	5.0
Seasonal Pool.....	8,000	26,500	2.2	7.2
Flood Control Pool				
Above Minimum.....	35,500	54,000	9.6	14.6
Above Seasonal.....	27,500	54,000	7.4	14.6
Total Storage.....	54,000		14.6	

*Subject to Change by MWCD

Surface Areas (Acres)

Minimum Pool.....	1,430
Seasonal Pool.....	1,800
Flood Control Pool.....	2,620

Backwater Along Main Stream (Miles)

Minimum Pool.....	11.9
Seasonal Pool.....	12.5
Flood Control Pool.....	14.1

CLENDENING LAKE

PERTINENT DATA (Cont'd)

RESERVOIR DATA (Cont'd)

DAM

Type - Rolled earth fill with impervious core
Maximum height, feet.....64
Top length, feet.....950
Top width, feet.....20
Base width, feet.....460

SPILLWAY

Type - Uncontrolled saddle spillway at right
(west) abutment
Crest length, feet.....128
Crest elevation, feet above NGVD.....910.5
Design discharge, cubic feet per second.....13,200
Surcharge, feet.....13

OUTLET WORKS

Type - Intake structure with tunnel and stilling basin.

Intake structure - Reinforced concrete with horseshoe tunnel, siphons,
and control gates.

Siphons - To maintain seasonal pool, a 1'-6" diameter siphon is
located in each of the two outer sluices, in front of gates No. 1 and
3, discharging into the middle sluice below gate No. 2.

Invert elevation of siphons, feet above NGVD.....897.25
Number of control gates.....3
Size of control gates, feet.....3'6"x7'
Invert elevation of control gates, NGVD.....862
Maximum outlet discharge, cfs, at.....18-1900
spillway elevation, all gates open

TUNNEL

Type - Horseshoe, concrete lined
Number of tunnels.....1
Size, feet.....7'6"x8'
Length, feet.....473.5

STILLING BASIN

Type - Conventional jump type with a rising invert located between the
tunnel portal and the stepped portion of the apron, discharging onto
baffle blocks and an end sill. A small rectangular sluiceway at
tunnel exit elevation is provided thru the center of the rising invert
for drainage of the tunnel.

Width, feet.....33
Length including outlet transition, feet.....93.75

U.S. ARMY ENGINEER DISTRICT, HUNTINGTON
CORPS OF ENGINEERS
HUNTINGTON, WEST VIRGINIA

**INSTRUCTIONS TO DAMTENDER
CLENDENING LAKE**

PROJECT MANUAL
FOR
WATER CONTROL MANAGEMENT
CLENDENING LAKE - BRUSHY FORK OF STILLWATER CREEK

2003

EXHIBIT B

TABLE OF CONTENTS

Sub-Section	Title	Page
Section I - General Operation Instructions		
1-01.....	General.....	1-1
1-02.....	Gate Regulation Technique.....	1-1
	a. General.....	1-1
	b. Siphons.....	1-1
	c. Sluice Gates.....	1-1
1-03.....	Routine Operation.....	1-2
1-04.....	Operation for Stillwater Creek, Muskingum River, and Ohio River.....	1-2
1-05.....	Emergency Operation.....	1-3
1-06.....	Emergency Operations during Communications Failure	1-4
1-07.....	Emergency Drawdown Operation	1-5
1-08.....	Public Notification of Unusual Releases.....	1-5
Section II - Collection of Hydrometeorological Data		
2-01.....	Precipitation at Clendening Lake.....	2-1
	a. General.....	2-1
	b. Official Precipitation Gage.....	2-1
	c. Regular Readings.....	2-1
	d. Recording Precipitation Gage.....	2-1
	e. Extra and Special Readings.....	2-1
	f. Satellite Platform Stations.....	2-1
	g. Snow Depth and Moisture Content.....	2-2
2-02.....	Precipitation For National Weather Service.....	2-3
Section III - Collection of Streamflow Data		
3-01.....	General.....	3-1
3-02.....	Gages For Regulation of Clendening Lake.....	3-1
3-03.....	Telephonic Gages.....	3-1
3-04.....	Data Collection.....	3-2

TABLE OF CONTENTS (Cont'd)

Sub-Section	Title	Page
Section IV - Completion and Transmission of Reports		
4-01.....	Regular Reports.....	4-1
	a. Weekly Report, ORH Form 14.....	4-1
	b. Daily Morning Report.....	4-1
	c. Gate Operation Report.....	4-2
	d. Water Quality Report.....	4-2
4-02.....	Extra Reports.....	4-3
4-03.....	Special Reports.....	4-3
	a. Reporting Criteria.....	4-3
	b. Special Report Data.....	4-3
	c. Transmission of Special Reports.....	4-4
4-04.....	Cell Phone as Standby Communication.....	4-4
4-05.....	Letter Reports.....	4-4
	a. General.....	4-4
	b. Downstream Channel Conditions.....	4-4
	c. Lake Area Conditions.....	4-5
	d. Low-Flow Releases.....	4-5
	e. Functioning of the Dam.....	4-5
	f. Water Quality Reports.....	4-5

LIST OF TABLES

Table No.	Title	Page
1-1	Control Stages and Travel Times ...	1-3
2-1	Precipitation Platform Communication Information ...	2-2
3-1	Pertinent Gage Data ...	3-2
3-2	Stream Gage Telephone Numbers ...	3-3

LIST OF PLATES

Plate No.	Title
1-1	Siphon Rating Curve
1-2	Slide Gate Rating Curve
3-1	Schedule for Reading Gages
3-2	Chart Handling Instructions
4-1	Weekly Report Form 14
4-2	Daily MORNING Report
4-3	Intranet Reporting Instructions

INSTRUCTIONS TO DAMTENDER

CLENDENING LAKE

SECTION 1 - GENERAL OPERATION INSTRUCTIONS

1-01. GENERAL

Follow instructions given in this section under one or more of the subsections at all times, except when other operations are required by Special Directive issued by the Water Management Section of the Huntington District Office and normally transmitted through the Muskingum Area Office. In the event contact cannot be made with personnel of the Area Office, Water Management Section personnel will issue Special Directives directly to the project.

In order to maintain downstream aquatic environment, the Clendening Lake outflow shall never be permitted to fall below 1.5 cfs.

Instructions contained in Special Directive will be applicable for a specific operation or for a stated period of time. After the instructions specified have been executed, resume operations in accordance with the following general instructions.

1-02. GATE REGULATION TECHNIQUE

a. General. Facilities provided for water control include two siphons for maintaining the pool level near conservation elevation, 898.0 feet NGVD, three rectangular conduits controlled by slide-type gates for passing usual flood flows, and an uncontrolled saddle spillway for passing extreme flood flows. Sequence and manner of operation where applicable, appear in subsequent paragraphs. Gates are to be opened or closed in such a manner as to prevent the stage at the outflow gage from changing more than 1.0 foot per hour unless directed by Water Resources Engineering Branch or under emergency procedure of sec 1-05 below.

b. Siphons. The two siphons, each 1.5 feet in diameter, are placed to draw water from the two outside conduits, No. 1 and No. 3, above the gates and discharge into No. 2 conduit below the gate. The invert elevation of 897.25 feet NGVD of the siphons allow discharge when the pool level is at or above 897.25 feet NGVD, but, not below. The peak flow of the two siphons is about 142 cfs at elevation 900 feet NGVD. **Plate No. No. 1-1** indicates the amount of flow through the siphons for various pool levels.

c. Sluice Gates. The three sluice conduits are 3.5 feet by 7.0 feet in size, with appropriately sized slide gates, and open from sills at elevation 862.0 feet NGVD. They are driven by electric motors mounted on gate operating stands at floor level of the gate house. The gates are numbered No. 1, No. 2, and No. 3 from left to right looking downstream. They are opened sequentially beginning with No. 2 and then No. 1 or No. 3, and are closed in reverse order. **Plate No. 1-2** is a table of partial gate openings for one slide gate, with a maximum flow of about 1,300 cfs with the siphon flow included.

1-03. ROUTINE OPERATION

After light rainfall or when there is a general stream rise, guidance presented in the following paragraphs shall be used to maintain proper project conditions.

During normal summer MIANO (Acronym for "Mid-April through November"), (See "Schedule for Reading Gages, Plate No. 3-1, for specified conditions), the lake is regulated by the siphons at or near summer recreation elevation 898 feet NGVD with occasional use of gates to release storm inflows or storage. Similarly during DEMIA (Acronym for "December to Mid-April") winter season, the lake is regulated by gate operations at designated minimum elevation, normally 893.0 feet NGVD. The required 1.5 cfs minimum discharge is affected by leaving a gate cracked as necessary when the pool level is below elevation 897.25 feet NGVD. At elevation 897.25 feet NGVD and above, the siphons provide the minimum discharge.

During MIANO season, Muskingum Water Conservancy District proposes to Huntington District Office the date for beginning fall drawdown, length of drawdown period and minimum pool elevation of the following DEMIA season. Water Resources Engineering Branch provides a schedule of decreasing pool elevations during the period, the last being the minimum pool elevation designated. The schedule is included in a Special Directive for Clendening issued to the Area Office which transfers by telephone and a copy mailed to the project. The usual drawdown period is 30 days to reduce pool for Clendening Lake to 893.0 feet NGVD. During the winter the Conservancy District normally suggests spring filling to begin 1 February each year with an intermediate level at 896 feet NGVD to be attained by 15 March. Summer recreation elevation 898 NGVD is always to be attained by 15 April unless some other major purpose intervenes.

Regulation under normal conditions (not under Special Directive) may be determined by Muskingum Area Office staff; however releases shall not exceed 270 cfs at any time of year unless specifically directed by the Water Management Section or under conditions of 1-05. After rainfall or when there is a general stream rise, guidance presented in the following paragraphs shall be used to maintain proper project conditions.

1-04. REGULATION FOR DOWNSTREAM CONTROL

a. Stillwater Creek. During reservoir regulation activity, the maximum allowable discharge of 540 cfs can be maintained during light to medium rainfall without causing any appreciable damage downstream along Stillwater Creek to the Tuscarawas River assuming Piedmont and Tappan discharges are not higher than control rates. These maximum control discharges for either MIANO or DEMIA season must be authorized by Special Directive from the Water Management Section except as authorized in 1-06 below. Control stages at Tippecanoe for MIANO and DEMIA seasons are 10.5 feet and 12.0 feet respectively. Similarly at Uhrichsville they are 3.5 feet and 5.0 feet. Maximum control stages are listed on **Table No. 1-1** next page, and must be authorized by a Special Directive from the Water Management Section.

TABLE NO. 1-1

CLENDENING LAKE
CONTROL STAGES AND TRAVEL TIMES

Station	Stream	Summer		Winter		Travel Hours
		Stage	Flow	Stage	Flow	
Clendening Dam	Brushy Fork	15.0	540	15.0	540	0
Tippecanoe	Stillwater Creek	10.5	1,200	12.0	1,530	.5
Uhrichsville	Stillwater Creek	3.5	2,233	5.0	3,099	10.4
Dresden	Muskingum River	16.0	23,450	18.5	32,000	41
Zanesville	*Muskingum River	19.5	38,200	21.5	48,000	45
McConnellsville	*Muskingum River	10.0	35,600	11.0	41,600	51
Marietta	*Ohio River	35.0		35.0		72

* DEMIA is December to mid-April; MIANO is from mid-April to November.

b. Muskingum River and Ohio River. Clendening Lake is operated integrally with Piedmont Lake and Tappan Lake when one or both of these main streams is in flood condition. Also, discharges from Clendening Lake as with Tappan and Piedmont Lakes, are to be coordinated with other Muskingum Basin projects to prevent adding to flow crests on the Tuscarawas, Muskingum, and Ohio Rivers.

1-05. EMERGENCY OPERATION

Emergency Operations are used to provide for increases in reservoir outflow when a rapid rate of pool rise indicates that the available storage capacity may be insufficient to completely control a flood. In an emergency operation, follow the procedures described below.

Whenever the lake level is above alert elevation 907.0 feet NGVD and rising, a constant check shall be made on the rate of rise of the lake level. The lake gage shall be read every hour, on the hour, and the rise in lake level computed for the previous hour. Based on the computed rate of rise in feet per hour, and the anticipated rainfall, an estimate is made to determine if the available storage capacity is sufficient to completely control the present flood.

Should the available storage appear inadequate, contact the Water Management Section immediately for operating instructions. In the event of failure of normal means of communication (telephone or cell phone), continuous and vigorous effort shall be made to contact the Water Management Section as described in sub-section 1-06.

The emergency procedure outlined in Section 1-06 shall be followed during periods when the Water Management Section or the Area Office cannot be contacted.

1-06. EMERGENCY OPERATION DURING COMMUNICATIONS FAILURE

During flood periods, every effort shall be made to contact personnel of the Water Control Section. If telephone and cell phone facilities fail, solicit the cooperation of local radio and TV stations, amateur and citizens band radio operators, or the State Police. When there is a delay greater than three hours, in establishing contact with the Water Management Section or the Area Office, AUTHORIZATION is hereby given to operate the project in accordance with the following Emergency Operation paragraphs.

a. If a Special Directive was in effect prior to communications failure, follow the operating instructions contained in the Special Directive until:

(1) The specific operation given in the Directive has been completed, or

(2) Twenty-four hours have elapsed since last contact with the Water Management Section either through the Area Office or otherwise, or

(3) Sufficient rainfall or snowmelt occurs which causes the lake and/or streams in the vicinity to rise rapidly.

b. Whenever any of the foregoing conditions occur, follow the operating instructions contained in sub-sections 1-03, 1-04, or 1-06c, whichever is applicable.

c. Continue the full effort to contact the Water Control Section and the hourly computations and gate settings until the lake level crests.

(1) If the pool level approaches elevation 909 feet NGVD, and continues to rise, prepare to gradually open the slide gates until the maximum seasonal outflow channel capacity of 270 cfs is reached, in an effort to pass inflow and prevent the pool going over spillway.

(2) If the pool level rises above spillway level of 910.5 feet NGVD, and goes on to 911.2 feet, use additional gate discharge up to full seasonal capacity of 540 cfs in order to stabilize the pool at that elevation or reduce further rise. If the pool rises above 911.2 feet NGVD, maintain maximum slide gate discharge until the pool crests and recedes to 911.2 feet NGVD. Then maintain elevation 911.2 feet NGVD while reducing discharge to channel capacity for the season. Maintain this discharge until the pool level recedes to spillway elevation 910.5 feet NGVD, and adjust discharge to hold elevation 910.5 feet NGVD until communication is reestablished with Water Control Section and a Special Directive is issued. (4) If the lake level crests below spillway elevation of 910.5 feet NGVD, gradually close the gates as necessary to maintain the crest lake level until communications are restored and a Special Directive is issued to begin drawdown operation.

(5) If the pool level is at or above spillway elevation 910.5 feet NGVD and a second rise occurs, the instructions outlined in the following paragraphs shall be followed.

a. During communication failure, project personnel should make frequent efforts to make contact with proper authority. If the pool level rises a second time to spillway elevation, 910.5 feet NGVD, use slide gate discharge up to channel capacity outflow for the season to pass inflow if possible and prevent or reduce further rise in pool level.

b. When the lake level ceases to rise, maintain the current gate settings until the lake level recedes to spillway elevation 910.5 feet NGVD, then gradually close the sluice gates as necessary to maintain the pool at this elevation until ordered by Special Directive to begin drawdown operation. If the pool again starts to rise, resume the above operations.

1-07. EMERGENCY RESPONSE

Should emergency drawdown become necessary, various procedures such as surveillance of the dam or notification of key personnel may be placed into effect, depending on the cause and its severity. Detailed information concerning these emergency actions can be found in the Flood Emergency Plan for Clendening Lake.

1-08. PUBLIC NOTIFICATION OF UNUSUAL RELEASES

Operation of reservoir projects during major floods has on occasion resulted in water releases being made which damaged privately-owned equipment or facilities located downstream, and caused claims or damage suits to be filed against the Government. To minimize the possibility of such claims or suits, the Clendening Lake Project Superintendent must stay informed and inform the Water Management Section of any and all developments along Brushy Fork and Stillwater Creek between the dam and Uhrichsville.

If required by unusual release patterns, obtain directions from the Water Management Section, who will coordinate the release with the Public Affairs Office for public notification procedures. Unusual release patterns include closure for maintenance purposes, special increases or decreases for downstream requests and requirements, and emergency, above channel capacity, discharges. Notification of large releases is to afford those likely to be affected an opportunity to take remedial measures in advance of the arrival of the release so as to prevent damage to or loss of their property.

CLENDENING LAKE

GATE RATING		ONE GATE																	*Discharge Through Opening at Elevation
GATE OPENING IN FEET	LAKE ELEVATION																		
	893.0	895.0	897.0	897.7	897.8	897.9	898.0	898.1	898.2	898.4	898.6	898.8	899.0	901.0	903.0	905.0	907.0	910.0	
0	0	0	0	7	22	54	70	81	91	107	120	130	140	144	148	152	157	161	
.1	18	20	21	21	35	67	83	94	104	120	133	143	154	158	162	167	172	177	
.2	31	32	34	34	49	81	97	108	118	134	147	157	167	172	177	181	187	192	
.3	43	45	47	48	62	94	110	121	131	147	160	171	180	186	191	196	202	208	
.4	56	58	60	61	75	107	123	134	144	161	174	184	194	200	205	211	217	223	
.5	68	71	74	74	88	120	136	148	158	174	187	197	208	214	220	226	232	239	
.6	80	83	87	88	102	134	150	161	171	187	200	211	221	227	234	240	247	254	
.7	93	96	100	101	115	147	163	174	186	201	214	224	234	241	248	255	262	270	
.8	105	109	113	114	128	160	176	188	198	214	227	233	248	255	262	270	277	285	
.9	118	121	126	127	141	174	190	201	211	227	241	251	262	269	277	284	292	301	
1.0	130	134	139	140	155	187	203	214	224	241	254	265	275	283	291	299	307	316	
1.1	142	147	152	154	168	200	216	228	238	254	268	278	289	297	306	314	322	332	
1.2	154	160	166	167	182	214	230	241	252	268	282	292	303	311	320	329	338	348	
1.3	167	173	179	180	195	227	244	255	265	282	295	306	316	326	335	344	353	364	
1.4	179	186	193	194	209	241	257	268	279	295	309	320	330	340	349	359	369	380	
1.5	191	199	206	208	222	254	270	282	292	309	323	333	344	354	364	374	384	396	
1.6	203	211	219	221	235	268	284	295	306	323	336	347	358	368	379	388	399	412	
1.7	215	224	233	235	249	281	298	309	319	336	350	361	372	382	393	403	415	428	
1.8	228	237	246	248	262	295	311	322	333	350	364	375	385	397	408	418	430	444	
1.9	240	250	260	262	276	308	324	336	346	363	377	388	399	411	422	433	446	460	
2.0	252	263	273	275	289	322	338	350	360	377	391	402	413	425	437	448	461	476	
2.1	263	275	285	288	302	334	351	362	372	390	403	415	426	438	451	462	476	491	
2.2	275	287	298	300	315	347	363	375	385	402	417	428	439	452	464	476	490	506	

Plate No. 1-1

*Includes Siphons Above Lake Elevation 897.25 and Seepage

CLENDENING LAKE

GATE RATING		ONE GATE																	*Discharge Through Opening at Elevation
GATE OPENING IN FEET	LAKE ELEVATION																		
	893.0	895.0	897.0	897.7	897.8	897.9	898.0	898.1	898.2	898.4	898.6	898.8	899.0	901.0	903.0	905.0	907.0	910.0	
2.3	286	299	310	313	327	360	376	388	395	415	429	440	451	465	478	491	505	522	
2.4	298	311	322	325	340	372	389	400	411	428	442	453	464	478	492	505	519	537	
2.5	309	322	334	338	353	385	402	413	424	441	455	466	477	492	506	519	534	552	
2.6	320	334	347	351	365	398	414	426	436	453	468	479	490	505	519	533	549	567	
2.7	332	346	359	363	378	410	427	438	449	466	480	491	503	518	533	547	563	582	
2.8	343	358	371	376	390	423	440	451	462	479	493	504	515	531	547	562	578	598	
2.9	355	370	384	388	403	436	452	464	474	492	506	517	528	545	560	576	592	613	
3.0	366	382	396	401	416	448	465	477	487	504	519	530	541	558	574	590	607	628	
3.1	380	396	411	416	430	463	480	491	502	519	534	545	556	574	590	607	624	646	
3.2	393	410	425	430	445	478	495	506	517	534	549	560	571	589	606	623	641	664	
3.3	406	424	440	445	460	493	509	521	532	549	564	575	586	605	623	640	659	682	
3.4	420	438	454	460	475	507	524	536	547	564	579	590	601	620	639	657	676	700	
3.5	434	452	469	475	489	522	539	551	562	579	594	605	616	636	655	674	693	718	
3.6	447	466	484	489	504	537	554	566	576	594	608	620	632	652	671	690	710	735	
3.7	460	480	498	504	519	552	569	580	591	609	623	635	648	667	687	707	727	753	
3.8	474	494	513	519	534	567	583	595	606	624	638	650	662	683	704	724	745	771	
3.9	488	508	527	534	548	581	598	610	621	639	653	665	677	698	720	740	762	789	
4.0	501	522	542	548	563	596	613	625	636	654	668	680	692	714	736	757	779	807	
5.0	634	660	687	695	708	743	760	772	783	802	817	830	842	869	896	922	949	984	
6.0	776	808	838	848	864	898	915	928	939	958	974	987	1000	1033	1064	1094	1125	1167	
7.0	874	912	945	956	972	1005	1023	1036	1047	1066	1083	1096	1109	1145	1179	1211	1244	1291	

Plate No. 1-1

*Includes Siphons Above Lake Elevation 897.25, and Seepage.

SECTION II - COLLECTION OF HYDROMETEOROLOGIC DATA

2-01. PRECIPITATION AT CLENDENING LAKE

a. General. Obtain precipitation data by direct observation of the rain gage at the damsite. Instructions for preparation and transmission of hydrologic reports are contained in Section IV.

b. Official Precipitation Gage. The standard National Weather Service (non-recording) rain gage at the damsite is designated as the gage for official use.

c. Regular Readings. Measure and discard precipitation contained in the standard gage about 0730 hours daily. Observe and record the times of beginning and ending of precipitation. The times of beginning and ending may be read from the recorder chart of the recording precipitation gage when "unknown" or "during night." Instructions for the preparation and transmission of precipitation reports are contained in Section IV. These instructions are for Corps of Engineers purposes and are not be considered as superseding observation instructions received from the National Weather Service.

d. Recording Precipitation Gage. Check the recording Precipitation gage about 0730 hours daily. Remove punched tape record monthly, marking record and unused portions with date and time and mail the record to National Weather Service, Columbus in the envelope provided. Install new roll of tape as needed. Empty collector bucket as needed after between 10 and 15 inches has been collected and add two quarts of antifreeze oil if between 1 October and 1 May.

e. Special and Extra Readings. Take special readings of the precipitation gage when requested by the Water Management Section through the Muskingum Area Office and extra readings whenever required by the Schedule for Reading Gages, **Plate No. 3-1**. When taking these readings, do not empty the gage at any time except the regular time. Report the total which has fallen since the regular time of reading even though a portion of it may have been reported in a previous extra reading. The regular reading on the morning following any extra readings should always include the amounts reported in the extra readings. Instructions pertaining to the transmission of extra and special precipitation readings are contained in Section IV.

f. Satellite Platform Stations. Three precipitation stations, Cadiz, Piedmont, and Tippecanoe are equipped with a data collection platform which has a voice modem. It answers a telephone caller by synthetic voice. After a few seconds of high pitched tone, the voice gives the latest reading and time of reading of each parameter reported by the platform. Precipitation is called "rain" and stream stage, "level". The message ends with battery voltage and time of reading.

One should note that the time given by the platform is Greenwich Mean Time (GMT). To convert to Eastern Daylight or Eastern Standard Time, subtract 4 or 5 hours, respectively. Reporting information on satellite precipitation stations in the Stillwater Creek Basin is listed below in **Table No. 2-1**.

TABLE NO. 2-1

PRECIPITATION PLATFORM COMMUNICATION INFORMATION

Location/ of Gage	Equipment	Frequency		Data	
		Channel Voice No	Update Interval	Trans - mitted	Trans - mission
Piedmont Lake	1/	35	60 min.	P,E	4 Hours
Clendening Lake	1/	35	30 min.	P,S	4 Hours
Tappan Lake	1/ v	55	60 min.	P,S	4 Hours
Tippecanoe	1/	23	60 min.	P,S	4 Hours
Newcomerstown	1/ v	35	60 min.	P,S	4 Hours
Coshocton	1/ v	35	30 min.	P,S	4 Hours

1/ Precipitation equipment same at all platform reported stations:
Tipping-bucket gage and platform.

P - precipitation in inches

E - elevation in feet above NGVD

S - stream stage in feet above gage zero

V - Voice platform answers telephone query with electronically synthesized voice in addition to transmitting via satellite.

g. Snow Depth and Moisture Content. During the winter, make regular measurement of snowfall and snow depth about 0730 hours daily. Measurements of the water content of the snow on the ground are needed in order to determine the amount of water which may run off during a warm spell or with any wind and rainfall which may occur. To determine the water content of the snow, obtain a representative snow sample at an undisturbed location by forcing the outside container of the rain gage through the snow to the ground surface. Then, using a shovel or thin sheet of metal to hold the snow cover within the container, remove the container from the ground.

The water content of the sample can be measured by placing the outside container in a vessel of warm water, and then pouring the melted snow into the inside container of the gage for a reading with the measuring stick. On no account should the vessel containing the snow be exposed to extreme heat because of the possibility of loss by evaporation. Measure water content of the snow as often as indicated below:

- (1) Each day when any new snowfall occurs
- (2) Each day when rain falls on existing snow cover.
- (3) Twice a week when there is snow cover if neither condition (1) nor (2) requires more frequent measurements.
- (4) By special request from the Water Management Section

2-02. PRECIPITATION FOR NATIONAL WEATHER SERVICE

The Ohio River Network, abbreviated ORN, formerly included precipitation stations and stations reporting both precipitation and stage. The ORN stations in or near the Stillwater Creek drainage basin have been combined with the Satellite Platform Stations, and now report electronically by INTRANET.

SECTION III - COLLECTION OF STREAMFLOW DATA

3-01. GENERAL

Obtain river and lake stage data by visiting the lake and outflow gages to read stage values from the recorder charts and by interrogating the surrounding telemeter gages. The necessary frequency for reading the gages at the project and for obtaining reports from the telemeter stations is set forth in the Schedule for Reading Gages, **Plate No. 3-1**, which appears at the end of this section. Instructions regarding the transmission of regular, extra and special reports of gage readings are contained in Section IV.

3-02. GAGES PERTINENT TO REGULATION OF CLENDENING LAKE

Information about gages of importance to operation of the project appears in **Table No. 3-1**, next page. Reading and Recording Gage Heights. List all gage readings in the records in order that complete data on the effect of the lake on natural flows will be available. Record lake gage readings in terms of elevation above NGVD but record all other gages in feet above gage datum, or zero of the gage. Gage datums are listed in **Table No. 3-1**, next page.

3-03. TELEPHONIC GAGES

In order to facilitate collection of stage information, data collection platforms having the additional capability of responding to telephone calls were installed at the lake gage well above the pool, and at Tippecanoe on Stillwater Creek. To obtain reports from the gaging stations via telephone, call the station telephone number. After a few seconds of high pitched tone, the platform will repeat, by synthesized voice, the platform identification, and then the most recent reading and time of reading of each parameter reported by the platform. Stage and elevation are called "level" and precipitation, "rain." The message ends with battery voltage, time of the reading, and repetition of the identification. One should note that the time given by the platform is Greenwich Mean Time (GMT). To convert to Eastern Daylight or Eastern Standard Time, subtract four or five hours, respectively.

The telephone numbers of these gages are classified as "Restricted" in order to avoid indiscriminate calls by unauthorized persons. The necessary frequency for obtaining reports from the "voice" gages is set forth in "Schedule for Reading Gages," **Plate No. 3-1**, at the end of this section.

Instructions pertaining to transmission of regular, extra and special reports of gage readings are contained in Section IV. Telephone numbers and code symbols assigned to the gages important to regulation of Clendening Lake appear in **Table No. 3-2**, next page.

TABLE NO. 3-1

PERTINENT GAGE DATA

Gage	Location	Code Symbol	Equipment	Reference Staff	Gages Other	Recorder	Gage Datum
Lake	Gate House	PESE6	DCP,H	ST	TI	RI	862.0
Outflow	Stilling B.	PESOF		SB			853.0
Tippe- Canoe	0.5 mile mouth of Brushy Fork	BL TISD6	VH	SH			849.0

S - Staff
T - Electric tape
DCP Data collection platform
H - Hydrologger gives stage in synthesized voice
R - Strip chart recorder
SB - Stilling Basin
W - Wire weight
V - Voice platform answers telephone query with an electronically synthesized voice in addition to transmitting via satellite.

TABLE NO. 3-2

STREAM GAGE TELEPHONE NUMBERS

Gage	Code* Symbol	Telephone Number	Type of Device
Brushy Fork at Clendening Lake	CLBD6	██████████	Hydologger
Stillwater Creek at Tippecanoe	TISD6	██████████	Voice Platform

* Project abbreviation plus location on District Isohyetal Map.

3-04. DATA COLLECTION

Project personnel read the lake gage and outflow gage and telephone the voice platform at Tippecanoe reporting Stillwater Creek. All the values are recorded in the daily morning report and given to the District Data System, EC-WW, by ITRANET. Gate positions and operations are noted in the log and on Form 14 and the positions are included in morning and extra reports to the Area Office. Supplemental lake and outflow data, discussed in next section, are taken along with regular readings or soon after.

The Morning Report data are given by Clendening as detailed in Section IV, and as shown in **Plate No. No. 4-2** at the end of Section IV. Supplemental data, when required, are called for by Area Office in the same sequence immediately after sending the regular data to the Water Management Section. **Plate No. 4-2** is a three page form, and each page has a Supplemental Data block to furnish requested information to the Water Management Section. Data collection platforms report stage data at all the locations (plus precipitation at some stations) listed above in **Table No. 3-1** previous page. They transmit the data by electronic signal to the LRD downlink via satellite each four hours. The LRD Water Control System retrieves from the downlink and disseminates hourly to the Water Management Section WCS data base. By use of the "SCAN" command with the portable terminal assigned, Area Office personnel can access the most recent readings from area stations that are reported by platform, as mentioned in 3-03.

**SCHEDULE FOR READING GAGES
CLENDENING LAKE**

The regular stream gages, TI or RI and HT or TH, must always be read and recorded immediately before each gate operation except when they have been read in the last hour with no intervening gate operation. They must also be read within one hour after completion of any operation. However, when the gates are being operated practically continuously, the gages need not be read before and after each individual operation; but readings at one-hour intervals including the readings before the first and after the last operation will be sufficient. If the recorders are operating properly, the above gage heights may be read from the charts at the time of the next reading. Stream gages and the precipitation gage shall be read at least as often as shown in the table below.

CONDITIONS	SCHEDULE A(1) Normal Conditions		SCHEDULE B(1) Flood Threat		SCHEDULE C(1) Flood Condition		SCHEDULE D (1) Major Flood Condition	
	MIANO*	DEMIA**	MIANO*	DEMIA**	MIANO*	DEMIA**	MIANO*	DEMIA**
Lake gage elevation	Below 898.7	Below 894.2	898.7-902.3	894.2-898.2	902.3-908.5	898.2-908.5	Above 908.5	Above 908.5
Gate discharge c.f.s.	Below 270	Below 270	270-405 (5)	270-405 (5)	405-540 (5)	405-540 (5)	Above 540 (5)	Above 540 (5)
Precipitation within 24 hours (6)	Less than 0.75	Less than 0.50	0.75-1.25	0.50-1.00	1.25-2.50	1.00-2.50	More than 2.50	More than 2.50

READ GAGES

TI and HT	At 0730 & 1330(2)	At 0730 & 1330	At 0730, 1330, 1930 & 0130	At 3 hour intervals (3)
RI and RH Charts	Readings for 0730, 1330, 1930 & 0130(4)	Readings for 0730, 1330, 1930 & 0130(4)	Readings for 0730, 1330, 1930 & 0130(4)	Readings for 0730, 1330, 1930 & 0130(4)
Precipitation Gage	Daily at 0730	Daily at 0730 & 1330	At 0730, 1330, 1930 & 0130	At 3 hour intervals
SI, TI, RI, TH HT, RH, and CH	Twice Weekly (as check)	Twice weekly (as check)	Twice weekly (as check)	Twice weekly (as check)

- (1) When any one of the conditions listed under schedule A, B or C is exceeded, place the next higher schedule into effect immediately and notify designated personnel of the Muskingum Area Office by person-to-person telephone call. If unable to make contact, similarly call Hydrology and Hydraulics Branch personnel listed in paragraph 4-03c.
- (2) Take readings on work days regularly and at other times by special arrangement.
- (3) Whenever the water level at the lake gage is between elevation 908.5 and 910.5 and rising, or at elevation 910.5 or above, read the lake gage and Tippecanoe gage hourly.
- (4) The 1330, 1930, and 0130 readings on weekdays and all readings for Saturday and Sunday may be obtained from the chart at the time of the next scheduled reading of visual gages. If necessary to obtain the readings desired, roll the chart back and, after taking readings, return to the proper position-- all according to instructions contained in Exhibit No. III-2.
- (5) Any and all gate discharge greater than 270 c.f.s. must be authorized by Hydrology and Hydraulics Branch except under conditions of paragraph 1-05 c.
- (6) If precipitation has occurred since the morning reading and amounted to 0.20" in winter or 0.50" in summer, or if snowmelt has occurred sufficiently to cause a rise in lake or outflow, read the lake gage, outflow gage, and rain gage at 1330 hours and transmit the information to the Muskingum Area Office.

Once a particular schedule is in effect, follow that schedule for a minimum of 24 hours before placing a lower schedule into effect or until such time that conditions require the use of a higher schedule. The foregoing table lists the minimum number of gage readings required. Record all gage readings made in addition to those required by the foregoing table.

* MIANO - 16 April through 30 November

** DEMIA - 1 December through 15 April

CHART HANDLING INSTRUCTIONS
Obtaining Weekend and Holiday Readings
From Stevens Strip Chart Recorders

STEVENS TYPE AP, TYPE A-71 OR A-35 RECORDER

1. First lift the lid or remove dust cover.
2. Lift pen from chart and secure pen in holder off paper position.
3. Facing Stevens recorder grasp knurled knob on the take up roll located in the rear of the recorder and to the left of the recorder paper. Turn knurled knob clockwise until enough paper is showing to obtain sufficient readings being careful paper does not come in contact with pen.
4. Record weekend and Holiday readings.
5. After sufficient readings have been obtained, grasp knurled knob, turn counterclockwise until slack is out of paper. Lower pen back on chart. If pen is off more than 1 hour, reset for correct time. To reset, grasp the knurled disc which is located on the right-hand side of the recorder just beneath the knurled knob of the supply cylinder. Pull the disc out to the right and rotate it until the paper is free. Advance paper until chart shows the correct time. Rotate the knurled disc to its normal location and push back in place to the left.
6. If you reset for time, make notation on chart.

STEVENS PAV-C OR CAV-C RECORDER

1. Face recorder and open recorder door.
2. Remove pen from chart by turning pen arm positioning screw clockwise.
3. Run the chart upward by moving and turning the knurled disk on the right end of the take up roller, upward, until enough record is showing to obtain readings. Be careful paper doesn't come in contact with pen.
4. Record week end and Holiday readings.
5. After readings are obtained, run the chart downward by turning the knurled disk on the right end of the take up roll, downward, until paper slack is removed and pen time is correct. Hold the chart in place; at the same time place a finger under the spiral spring belt, lift outward from the wall slightly stretching the belt, then release. Paper will stay taut.
6. Place pen back on the chart by turning pen arm positioning screw counterclockwise.
7. If pen is off more than 1 hour, reset for time. To reset, run chart downward until pen shows correct time on the chart. Holding chart in place lift outward spiral spring belt, stretching slightly, then release belt.
8. If you reset for time, make a notation on chart. Include in notation time, date, stage from counter, etc.

SECTION IV - COMPLETION AND TRANSMISSION OF REPORTS

4-01. REGULAR REPORTS

a. Weekly Report, ORH Form 14. To reduce the probability of error in transcribing data from other forms, enter gage readings through the week on a copy of Form 14. Lake and outflow gage readings will be obtained for every six hours (0130, 0730, 1330 and 1930) during periods when the project is attended and recorded on the form.

The Schedule for Reading Gages, **Plate No. 3-1**, defines conditions for taking more frequent readings of gages. After entering each of the readings on the form, check the accuracy of the readings as recorded. If doubt arises, investigate to the extent necessary to be certain of the readings. During normal conditions, if the 1930 and 0130 readings have not been recorded on the form, take them from the recorder charts when taking the 0730 Project Report readings. After any period in which the project was not attended, obtain all missing readings from the recorder charts and record on Form 14. See **Plate 3-2** for instructions on how to turn back charts to obtain missed readings and the proper method to reset the gage after doing so. On Monday morning, or Tuesday if the project was not attended on Monday, record any missed readings along with the 0730 readings. Check the accuracy of the data on the typed original compared to the handwritten form. Mail the original typed form to the District Office marked "Attention Water Resources Engineering Branch." Begin a new Form 14. A sample Form 14, **Plate No. 4-1**, is included at the end of this section.

b. Daily Morning Report. Use of the ORH-13 form has been discontinued. An all new reporting program was installed at the dam in May 1998. The program is a fully computerized three page, menu-driven master data sheet which is virtually self-explanatory, with a convenient auto-prompt feature, easily completed by filling the empty data boxes. This form is used to record the regular morning report at Clendening Lake, and then used to transmit the data to EC-WM.

The regular morning readings at the project, including precipitation, readings of the lake "L" gage, outflow "O" gage, gate positions, river stages and gate operations shall be recorded each day. After recording, the data will be transmitted via the District INTRANET System for the Water Resources Engineering Branch by approximately 0800 hours on each day in which the project is attended.

An example of this report is shown at the end of this section as a three page Project Data Input Form, **Plate No. 4-2**. The proper manner of reporting the data and completing the data in detail are shown in a printout of project reporting instructions found at the end of this section as **Plate No. 4-3**. This record can be viewed at the Clendening Lake web page at:

<https://cwms.lrh.usace.army.mil/CLB/index.htm>
<https://cwms.lrh.usace.army.mil/CLB/projinfo.htm>

Transmit reports for Saturdays, Sundays, and Holidays on which the project is attended as on regular work days. Transmit reports for unattended days after transmission of the current report for the first working day which follows. In each regular or extra Daily Morning Report, also include any telephonic readings made since the previous Project Information report.

If conditions are such that the daily report cannot be transmitted to the District Intranet System by 0830 hours, transmit the report by telephone or fax to Water Resources Engineering Branch, then enter the data into the computerized report form when it becomes available.

c. Gate Operations Report. The second report accessed from the Index Page is the Gate Operations Report. This report is used to record information about gate operations. Each gate operation should be recorded at the time it occurs and all gate operations are reported by the INTRANET SYSTEM. Choose the Gate ID from a drop down menu. If several gate operations are performed within a short period of time, up to 6 (six) gate operations may be reported on a single form. Transmit all gate valve operations since the previous report and transmit with each morning or extra report. List them in chronological order after project report data. See the example in **Plate No. 4-2**. An unlimited field is also provided to make any additional comments.

As in the Project Report, a password is necessary to submit the gate Operation Report to the WCDS-A computer. The same password is used to the Project Report and the Gate Operations Report (see Para. 4.01.b).

If the report is submitted with the proper password, a confirmation screen will be transmitted back to the terminal. If the information is correct, click on the 'Correct' button at the top of the page.

The information will be entered into a permanent record. This record can be viewed at the Clendening Lake web page at:

<https://cwms.lrh.usace.army.mil/CBS/gateops.htm>

d. Water Quality Report. The third report available from the Index Page is the Water Quality Report. This report is used during the rare times that the lake is subject to stratification. During rare periods of lake stratification the weekly temperature-dissolved oxygen profile and water quality data are included in a separate report. Monitoring begins when a special directive is sent by Water Control Section at the request of Water Quality Section. All Water Quality data is submitted in accordance with the special directive. Monitoring ends when the lake is no longer stratified and the Water Quality team requests the Water Management Section to issue a special directive ending monitoring.

As in the Project Report, a password is necessary to submit the Water Quality Report to the WCDS-A computer. The same password is used to the Project Report and the Water Quality Report (see Para. 4.01.b). If the report is submitted with the proper password, a confirmation screen will be transmitted back to the terminal. If the information is correct, click on the 'Correct' button at the top of the page. The information will be entered into a permanent record.

This arrangement is illustrated in **Plate No. 4-2** at the end of this section. All records can be viewed on the Clendening Lake web page at:
<https://cwms.lrh.usace.army.mil/CBS/waterqual.htm>

4-02. EXTRA REPORTS

Always transmit extra reports, as indicated by the Schedule for Reading gages, **Plate No. 3-1**, to INTRANET over the project computer terminal in the same way as the regular MORNING report. If some circumstance prohibits, such as for example, malfunction of the terminal or lack of terminal competency by personnel on duty, attempt to telephone the report to Water Resources Engineering Branch in the District Office.

Failing this attempt, telephone the report to one of the Water Resources Engineering Branch personnel in the order listed below in paragraph 4-03c.

4-03. SPECIAL REPORTS

a. Reporting Criteria. Special reports include any report not regularly scheduled or called for by the Schedule for Reading Gages. A special report should be made when an event occurs concerning the project that Water Resources Engineering Branch should have knowledge of or when requested by the Water Control Section.

b. Special Report Data. The following types of occurrences or information are examples of occasions for or subjects of special reports.

(1) Extraordinary meteorological event such as a tornado or blizzard, or heavy precipitation after 0730 hours.

(2) Gate positions and/or operations.

(3) Flooding upstream or downstream.

(4) Request for special operation.

(5) A catastrophe such as drowning.

(6) Unusual or abnormal water quality condition in the lake, inflow streams, or downstream reasonably close to the dam.

(7) Moisture content of snow.

(8) Outflow temperature and/or air temperature at time other than 0730 hours.

(9) Local weather forecast.

c. Transmission of Special Reports. All special reports should be made at any time of day or night, including weekends and holidays, or when requested by Water Resources Engineering Branch. During office hours, submit them by telephone; however, if it is impossible by telephone, utilize the District Cell Phone network. When making telephone calls after hours or during weekends or holidays, unless advised that the Water Resources Engineering Branch will be on duty, place a person-to-person call to one of the following Water Resources Engineering Branch personnel, in the order listed on **Plate No.4-3**, page 6 of 6.

4-04. CELL PHONE AS BACKUP COMMUNICATION

Keep the Cell Phone turned on at all times when anyone is on duty at the project office, including overtime periods, since a District Office operator is sometimes on duty outside of regular office hours. Also, messages may be relayed through other projects. When there is difficulty in transmitting reports to INTRANET or via telephone, attempt to transmit by Cell Phone either direct to the District Office or by relay through another project which has contact with the District Office.

4-05. LETTER REPORTS

a. General. All letter reports pertaining to water control management will be addressed to the District Engineer, Attention: Water Resources Engineering Branch.

b. Downstream Channel Conditions. At the request of the Water Resources Engineering Branch, inspection of critical areas downstream from the dam will be made for conditions listed below to observe encroachment on the channel, indiscreet utilization of low-lying areas, and flooding conditions, as follows:

(1) During flood periods when maintaining the maximum allowable outflow stage on the 'H' gage, inspections will be made along Stillwater Creek to Tippecanoe, Ohio.

(2) Inspections will be made downstream to Tippecanoe, Ohio, during or immediately after periods of unusual storage releases.

(3) If complaints of flooding are received, notify the WRE Branch immediately, then make an inspection of the specific areas as soon as practicable.

(4) An any other times, as requested by the Water Resources Engineering Branch, and under (3) above, the essential items to note and report are: (a) persons or communities involved; (b) nature of complaint; and (c) extent and depth of flooding. Make a letter report, containing pictures, cross sections or sketches of the findings as soon as practicable. If immediate action appears necessary, make a brief initial report via telephone to the Water Resources Engineering Branch.

c. Lake Area Conditions. During periods of lake storage above summer recreation pool elevation 898 feet NGVD, inspections shall be made within the lake area. Essential items to look for and observe are bank slippage and effects of wind and wave erosion.

d. Low-Flow Releases. During periods of low flow release downstream observations shall be made of stream depth, fish and wildlife, water odor, and discoloration, if any, as directed by the Water Resources Engineering Branch. Stream gages, rain gages and temperature equipment shall be periodically checked for proper functioning and performance or when directed by the Water Resources Engineering Branch. During periods of stratification, outflow temperature requirements will be maintained according to the Water Resources Engineering Branch Special Directives

e. Functioning of the Dam. Functioning of the dam shall be observed at all times, including performance of gates, valves machinery and outlet structure and the presence of any leakage. During flood storage periods when the lake level reaches or exceeds the Alert Elevation, 908 feet NGVD for Clendening Lake, daily and hourly observations are made and reported under provisions of the Dam Operations Management Policy in addition to the normal weekly observations made under the policy. At these or other times requested by Water Resources Engineering Branch for a particular use, forward a copy of such observations as soon as practicable to Water Resources Engineering Branch as a letter report.

f. Water Quality Reports. Any unusual water condition should be reported to the Water Resources Engineering Branch, particularly:

(1) Floating debris, oil, scum and other floating materials from municipal, industrial, or other discharges such as from agricultural practices in such amounts that they are unsightly or detrimental to wildlife or public health.

(2) Unusual color, odor or other condition in such degree as to be a nuisance.

(3) Any fish kills, plankton blooms or insects to the degree that they are a nuisance should be reported.

(4) The Water Resources Engineering Branch should be informed concerning application of chemicals to the water or to surrounding land. This includes fertilizers and pesticides.

RESERVOIR WEEKLY REPORT

REPORT'S CONTROL SYMBOL ORHED-B-3

STATION

WEEK ENDING

GAGE RECORDS

GATE OPERATING RECORD

DATE	TIME		GAGES			GATE NO.	AMT. OF OPENING		PURPOSE
	START	END	T.I.	S.B.	H.T.		INITIAL	FINAL	
29	1930		901.57	-----	-----	1			
30	0130		901.56	-----	-----	1			
	0730		901.55	859.05	858.42	2	00.2	01.0	
	0830		901.55	859.05	858.39	1			
	1230		901.53	858.95	858.22	2	01.0	02.0	
	1330		901.51	858.95	858.26	1			
	1500		901.50	859.05	858.39	2	02.0	02.5	
	1600		901.49	859.05	858.44	1			
7/1/89	0130		901.35	-----	-----	1			
	0730		901.26	859.40	858.78	1			
	1330		901.18	-----	-----	1			
	1930		901.09	-----	-----	1			
2	0130		901.01	-----	-----	1			
	0730		900.91	859.05	858.48	2	02.5	03.3	
	0830		900.88	859.05	858.53	1			
	1330		900.77	-----	-----	1			
	1930		900.66	-----	-----	1			
3	0130		900.56	-----	-----	1			
	0730		900.46	859.50	858.93	1			

CHECK READINGS

FINAL POSITION OF GATES

Date	Time		T.I.	S.I.	R.I.	Gate No. 1 Closed
6/29/89	0730		901.58	901.58	901.58	Gate No. 2 Open 03.3
7/3/89	0730		900.46	900.46	900.46	Gate No. 3 Closed
		C.H.	T.H.	R.H.	H.T.	
6/29/89	0730	858.66	858.66	858.66	858.66	SIGNATURE <i>John A. McElhany</i>
7/3/89	0730	858.93	858.93	858.93	858.93	

CLENDING LAKE

PROJECT INFORMATION



USE THE MOUSE OR TAB TO MOVE BETWEEN FIELDS
ENTER WILL SUBMIT THE FORM

This file is a submission.

DATE	TIME
<input type="text" value="26 Aug 2008"/>	<input type="text" value="0730"/>

CURRENT PROJECT INFO

COE ID	PRECIP (IN)	POOL ELEV (FT-MSL)	TAIL WATER STAGE (FT)	FLOW (KCFS)	SNOW DEPTH (IN)	WATER EQUIVALENT (IN)	WEATHER CONDITIONS
6	<input type="text" value="0"/>	<input type="text" value="900"/>	<input type="text" value="850"/>	<input type="text" value="0"/>	<input type="text" value="0.0"/>	<input type="text" value="0.0"/>	<input type="text" value="0 Unchanged"/>

CURRENT GATE SETTINGS

GATE	S01	S02	S03
SETTING	<input type="text" value=".00"/>	<input type="text" value=".00"/>	<input type="text" value=".00"/>

ADDITIONAL STATION INFORMATION

COE ID	PRECIP (IN)	STAGE (FT)
TISD6	<input type="text" value="0"/>	<input type="text" value="0.0"/>

ADDITIONAL COMMENTS

CLENDENING LAKE

GATE OPERATIONS

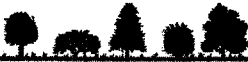

This file is a submission.

GATE ID	VALUE		DATE	TIME	
	Start	End		Start	End
<input type="text" value="S01"/>	<input type="text" value="0.0"/>	<input type="text" value="0.0"/>	<input type="text" value="26 Aug"/>	<input type="text" value="0700"/>	<input type="text" value="0705"/>
<input type="text"/>	<input type="text"/>	<input type="text"/>	<input type="text"/>	<input type="text"/>	<input type="text"/>
<input type="text"/>	<input type="text"/>	<input type="text"/>	<input type="text"/>	<input type="text"/>	<input type="text"/>
<input type="text"/>	<input type="text"/>	<input type="text"/>	<input type="text"/>	<input type="text"/>	<input type="text"/>
<input type="text"/>	<input type="text"/>	<input type="text"/>	<input type="text"/>	<input type="text"/>	<input type="text"/>
<input type="text"/>	<input type="text"/>	<input type="text"/>	<input type="text"/>	<input type="text"/>	<input type="text"/>

ADDITIONAL COMMENTS

PLEASE ENTER THE CLENDENING PASSWORD:



[CLICK HERE TO RETURN TO CLENDENING LAKE HOME PAGE \(WILL NOT SAVE DATA\)](#)

CLENDENING LAKE

Lake Quality Report



USE THE MOUSE OR TAB TO MOVE BETWEEN FIELDS
THE ENTER KEY WILL SUBMIT THE DATA

This file is a submission.

DATE	TIME	LAKE ELEV (FT)	WEATHER
26 Aug 200	0730	885.00	0 Unchanged

DEPTH (M)	TEMP (C)	D.O.	COND	TURB	pH
OUTFLO					

DEPTH (M)	TEMP (C)	D.O.	COND	TURB	pH
0.0					
1.0					
2.0					
3.0					
4.0					
5.0					
6.0					
7.0					
8.0					
9.0					
10.0					
12.0					

INTRANET REPORTING SYSTEM INSTRUCTIONS

LOGGING ON. Open the web browser or the (Microsoft (Internet Explorer or Netscape Navigator) to the following address:

<https://cwms.lrh.usace.army.mil/CLB/index.htm>

This Index Page contains links to information pertaining to Clendening Lake. The Data Submission Reports vary for each project, and report forms for one project cannot be substituted for another project. When submitting data for gate operations follow the link for Gate Operations.

PASSWORD. Each project has a unique password needed to submit the report to the CWMS-A system. The same password is used to the Morning Report and the Gate Operations Report (see Para. 4.02.15). While the information being submitted is not classified, the password should be protected to keep unauthorized personnel from gaining access to .mil computer systems. Questions about the password should be directed to the Water Control Section.

SUBMISSION. After all the project information has been recorded, click on the "Submit" button to send the report to CWMS-A or "Clear Form" to clear all the information out of the form and start over. If the password was correct, a SHEF compatible report will be sent back to the computer terminal. Information can be checked before the final submission. If there is any incorrect data on the report, use the browser's "back button", return to the Project Report Page to correct the information.

If the report was correct, click on the 'Correct' button at the top of the page, the SHEF confirmation screen will be transmitted back to the terminal. The information will be entered into a permanent record. If this password is missing or incorrect, attempts to submit the Project Report will be unsuccessful.

REPORTS. Three reports can be accessed from the Index Page: (1) The Daily Project Report (also called the Morning Report); (2) the Gate Operations Report; and (3) the Water Quality Report. Click on the picture or on the Report name to access a report.

DAILY PROJECT REPORT (MORNING REPORT)

When the Daily Project Report Page has been accessed, indicate if this is a new or a revised report. Check the date/time group.

CURRENT PROJECT INFO. The first table is used to record general information about the project at the time of the report.

Column 1 - Station Abbreviation. This column identifies the lake station. The first three letters comprise the abbreviation of the station name and the last letter and figure are a key to its location on the District Isohyetal Map. This five-digit group (CLBD6) is the abbreviation for the station and should always be used.

These station names have been coded into the web page and cannot be changed at the project. In completing this form prior to transmitting the data, list the stations in the following order: Tippecanoe(TISD6), and Newcomerstown(NECD5). Follow the example shown on **Plate No. 4-2**.

If there are any difficulties in relation to this, please contact the Water Control Section.

Column 2 - Precipitation. Record the amount of precipitation (to the nearest 1/100 inch) since the last report.

Column 3 - Lake Elevation. Use this column for reporting the lake "L" gage, in feet above NGVD, to the nearest hundredth foot. Please include decimal points.

Column 4 - Outflow Stage. Use this column for reporting the stage at the "O" gage, to the nearest hundredth foot. This is the stage reading of the gage in feet above NGVD.

Column 5 - Flow. This column can be used for recording the outflow if it becomes necessary.

Columns 6 and 7 - Snow and Water Equivalent. Report the depth of snow cover and its water content in these columns. Where a station does not make this report or no precipitation has been reported, send 0.00. Record the snow depth in inches to the nearest hundredth. Indicate a trace by OOT. Report the figures for snowfall and snow cover since the previous report.

Columns 8 - Weather Description. The drop down menu in this column is used to report the weather conditions by code at the time of the Project Report observation. When there has been no precipitation to report, show this group as NIL.

See this data on the Clendening Lake Web page address:

<https://cwms.lrh.usace.army.mil/CLB/projinfo.htm>

CURRENT GATE SETTINGS. The second table, Current Gate Settings, is used to record gate settings at the time. The table is a seven section - two row box. Column 1 is written Gate Settings.

Gate Settings - Column 2 through 4. These four columns are used for recording the openings of the slide gates. Column 2 is used for the left slide gate SO1, column 3 is used for the middle slide gate SO2, and column 4 is used for the right slide gate SO3. Each gate opening is reported to the nearest tenth of a foot. For example, 4.8 feet is reported as 048 and 6.0 feet as 060. The gates usually remain closed during normal operations. When all gates are fully open, instead of listing each gate separately, the word "open" will be transmitted in column 4. When all gates are partially open, an equal amount, instead of listing each gate separately, the word "all" will be transmitted in column 4 and the amount of opening in column 5. When all the gates are fully closed, the word "closed" is entered in column 4. When the gate settings are not uniform the individual columns from 2 through 4 are used to report the various openings. Transmission of the openings for each gate shall consist of a 3-digit number, and if the gate is closed, 000 is reported.

Low-Flow Control. During summer operations all routine inflow is passed through the 1.5 foot siphons discharging in front of the center gate. During winter operations, or when the pool is below elevation 898.0 feet NGVD, the lake level and outflow is controlled by the slide gates. When all gates are closed there will be a very small seepage at the sills. And, one of the gates may be cracked just enough for a small flow, this is the only low-flow control at Clendening Lake.

Additional Station Information - Report additional precipitation and stage information for TIPPECANOE(TISD6) and NEWCOMERSTOWN(NECD5) are entered in the SHEV box. Follow the example in **Plate No. 4-2**. Include any or all of the stage and precipitation in such messages: There is no water supply function at Clendening Lake.

Password. While the information being submitted is not classified, the password should be protected to keep unauthorized personnel from gaining access to .mil computer systems. Questions about the password should be directed to the Water Management Section.

After all the project information has been recorded, click on the 'Submit' button to send the report to WCDS-A or 'Clear Form' to clear all the information out of the form and start over. If the password was correct, a SHEF compatible report will be sent back to the computer terminal. Information can be checked before the final submission. If there is any incorrect data on the report, use the browser's "back button" to return to the Project Report Page to correct the information. If the information is correct, click on the "Correct" button at the top of the page. At this point, the report is sent to the WCDS-A computer for permanent storage.

This record can be viewed through the Clendening Lake web page at:
• <https://cwms.lrh.usace.army.mil/CLB/projinfo.htm>
See the example in **Plate No. 4-2**.

GATE OPERATIONS REPORT

The second report accessed from the Index Page is the Gate Operations Report. When the Gate Operations Report has been accessed, indicate if this is a new or a revised report. Check the date/time group.

This report is used to record information about gate operations. Each gate operation should be recorded at the time it occurs. If several gate operations are performed within a short period of time, up to 6 (six) gate operations may be reported on a single form.

Choose the Gate ID from a drop down menu. Transmit all gate valve operations since the previous report and transmit with each morning or extra report. List them in chronological order after project report data. Enter the data on the report in the following manner with the first entry for a new report. Use column one through six, successively for gate designation, initial gate opening, final gate opening, date, beginning time, and ending time. See the example in **Plate No. 4-2**.

In the second table, Additional Comments, an unlimited field is also provided to make any additional comments pertaining to the Gate Operations Report which have not been previously covered.

As in the Project Report, a password is necessary to submit the gate Operation Report to the WCDS-A computer. The same password is used to the Project Report and the Gate Operations Report (see Para. 4.02.15).

If the report is submitted with the proper password, a confirmation screen will be transmitted back to the terminal. If the information is correct, click on the 'Correct' button at the top of the page.

The information will be entered into a permanent record. This record can be viewed at the Clendening Lake web page at:

<https://cwms.lrh.usace.army.mil/CLB/gateops.htm>

WATER QUALITY REPORT

When the Water Quality Report has been accessed, indicate if this is a new or a revised report. Check the date/time group.

This report is used during the rare time the lake is subject stratification. Monitoring begins when a special directive is sent by the Water Management Section. The Water Management Section issues a special directive ending monitoring when it is no longer necessary.

The first table in the Water Quality Report has fields referring to conditions at the time the water quality sampling was performed. Record the date and time, the lake elevation in feet to the nearest hundredth, and the weather conditions.

The second table is used to record water quality data at the outflow gage on the surface. Record the water temperature in degrees Celsius, the Dissolved Oxygen (D.O.) content in mg/ml, the water condition, turbidity in n.tu and pH. The third table is used to record water quality at various depths. (a) The first column records the depth water depth, from the surface, in meters. This field is populated for the convenience of the data transcriber, but can be changed if conditions warrant. (b) The second column records the water temperature in degrees Celsius. (c) The third records the Dissolve Oxygen (D.O.) content in mg/ml. (d) The fourth column records the water condition. (e) The fifth column records turbidity in n.tu. (f) The sixth column records the pH. Not all of these readings will be taken at every recording session at every depth.

Supplementary Data - Below the table recording the water conditions, there is an unlimited field to provide additional comments. (a) Precipitation and snow cover amounts when either is ten (10) inches or more. (b) Moisture content of snow cover. (c) Precipitation at the dam during the past 24 hours, when greater than one (1) inch, by 6-hour period.

As in the Project Report, a password is necessary to submit the Water Quality Report to the WCDS-A computer. The same password is used to the Project Report and the Water Quality Report (see Para. 4.02.15). If the report is submitted with the proper password, a confirmation screen will be transmitted back to the terminal. If the information is correct, click on the 'Correct' button at the top of the page. The information will be entered into a permanent record.

This record can be viewed through the Clendening Lake web page at <https://cwms.lrh.usace.army.mil/CLB/waterqual.htm> This arrangement is illustrated in **Plate No. 4-2** in this section.

DIRECTORY OF KEY PERSONNEL

Huntington District Office - Water Resources Engineering Branch

Normal Work Hours [REDACTED]
0700 to 1600 hrs

Nights, Weekends, and Holidays Additional Extensions [REDACTED]

Water Resources Engineering Branch Personnel Home Telephone Number

[REDACTED] Chief, Water Management Section [REDACTED] *

[REDACTED] Water Management Section [REDACTED]

[REDACTED] Chief, Water Resources Engineering Branch [REDACTED] * unlisted

Pertinent telephone numbers which may be of value during flood emergency are listed below:

Muskingum Area Office

[REDACTED] Area Manager
Normal Work Hours, Night, weekend, Holiday, NWS observers [REDACTED]
Home [REDACTED]

Clendening Lake Project Office

[REDACTED] Commercial [REDACTED]
[REDACTED] Commercial [REDACTED]

Other Agencies

U. S. Geological Survey Commercial [REDACTED]
New Philadelphia, Ohio Commercial [REDACTED]

Nights, Weekends, Holidays Commercial [REDACTED]
Lowell Trimble Commercial [REDACTED]

National Weather Service Commercial [REDACTED]
Forecast Office, Commercial [REDACTED]
Hydrology Section Commercial [REDACTED]
Cleveland, Ohio Commercial from HDQ [REDACTED]

UPON APPROVAL OF NEPA DOCUMENTATION, THE DROUGHT CONTINGENCY PLAN
WILL BE FURNISHED FOR ENCLOSURE IN THE WATER CONTROL MANUALS.

The Huntington District includes the reach of the Ohio River between River Mile 127.2 (New Martinsville, W. Va.) and Mile 438.0 (3.5 miles downstream from Chilo, Ohio) below Pittsburgh, Pa. and the drainage areas of all tributaries entering the Ohio River between these two points. The total drainage area of the Ohio River basin above Mile 438, is 70,880 square miles. The drainage area of the Huntington District is 44,914 square miles.

For the status of former Federal navigation projects on the Big Sandy River, the Little Kanawha River and the Muskingum River, see pages R/H 16, R/H 11 and R/H 10 respectively.

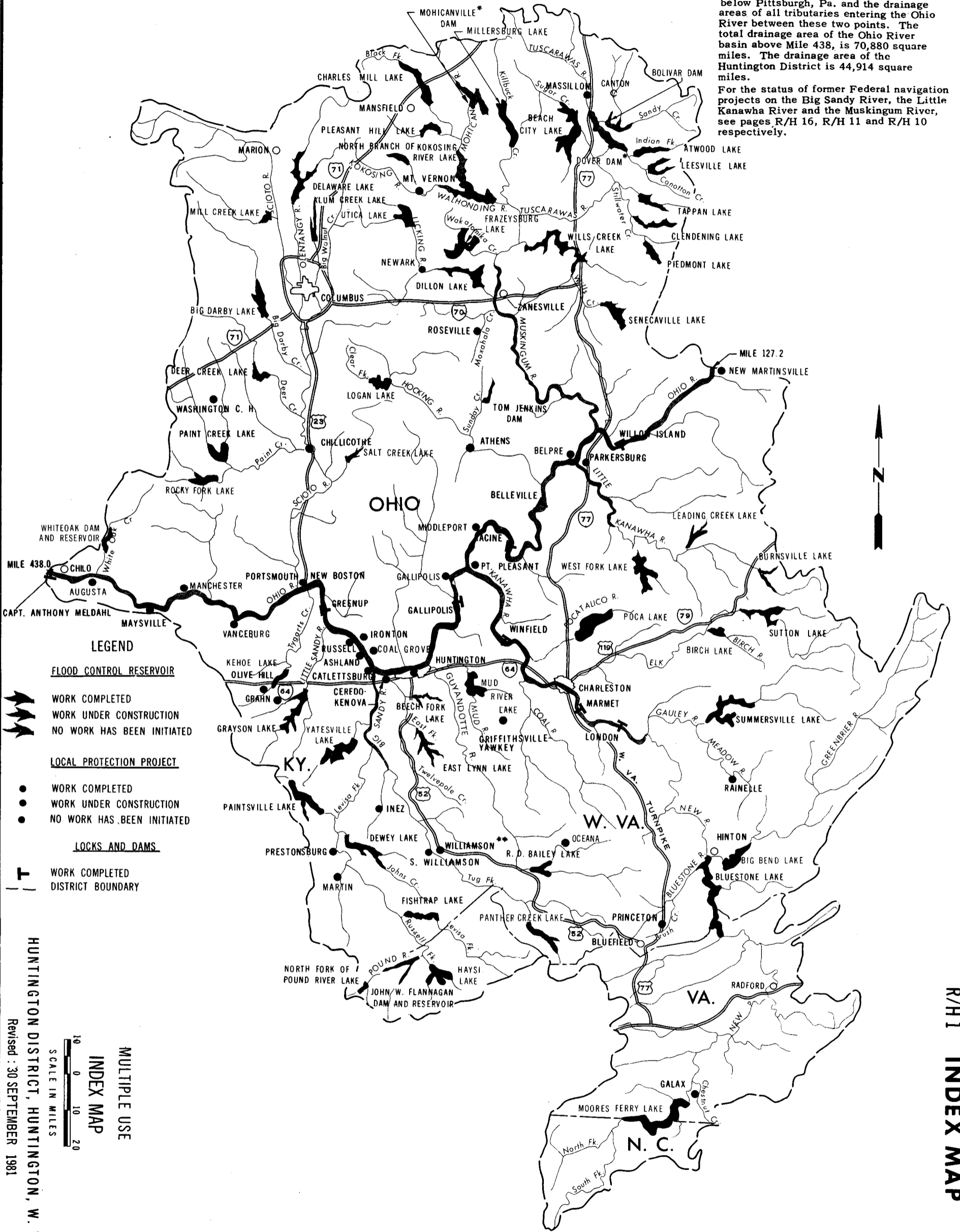

LEGEND

FLOOD CONTROL RESERVOIR

- WORK COMPLETED
- WORK UNDER CONSTRUCTION
- NO WORK HAS BEEN INITIATED

LOCAL PROTECTION PROJECT

- WORK COMPLETED
- WORK UNDER CONSTRUCTION
- NO WORK HAS BEEN INITIATED

LOCKS AND DAMS

- WORK COMPLETED
- DISTRICT BOUNDARY

MULTIPLE USE
INDEX MAP



HUNTINGTON DISTRICT, HUNTINGTON, W. VA.

Revised : 30 SEPTEMBER 1981









Plate No. 1-1

R/H 1 INDEX MAP F/C 1

*Dry dam, with flood control pool outlined.
**Completed project where further improvements are in progress or authorized.



LEGEND

-  WATERSHED BOUNDARY LINE
-  RESERVOIR SPILLWAY ELEVATION
-  REPORTING PRECIPITATION STATION
-  PRECIPITATION
-  STAGE
-  SATELLITE DATA PLATFORM
-  SATELLITE DATA PLATFORM PLANNED
-  TELEPHONE AND RADIO BACKUP
-  TELEPHONE OBSERVERS

BRUSHY FORK
OHIO

CLENDENING LAKE

DRAINAGE AREA MAP

DEPARTMENT OF THE ARMY
HUNTINGTON DISTRICT, CORPS OF ENGINEERS
HUNTINGTON, WV REDRAWN MARCH 2005

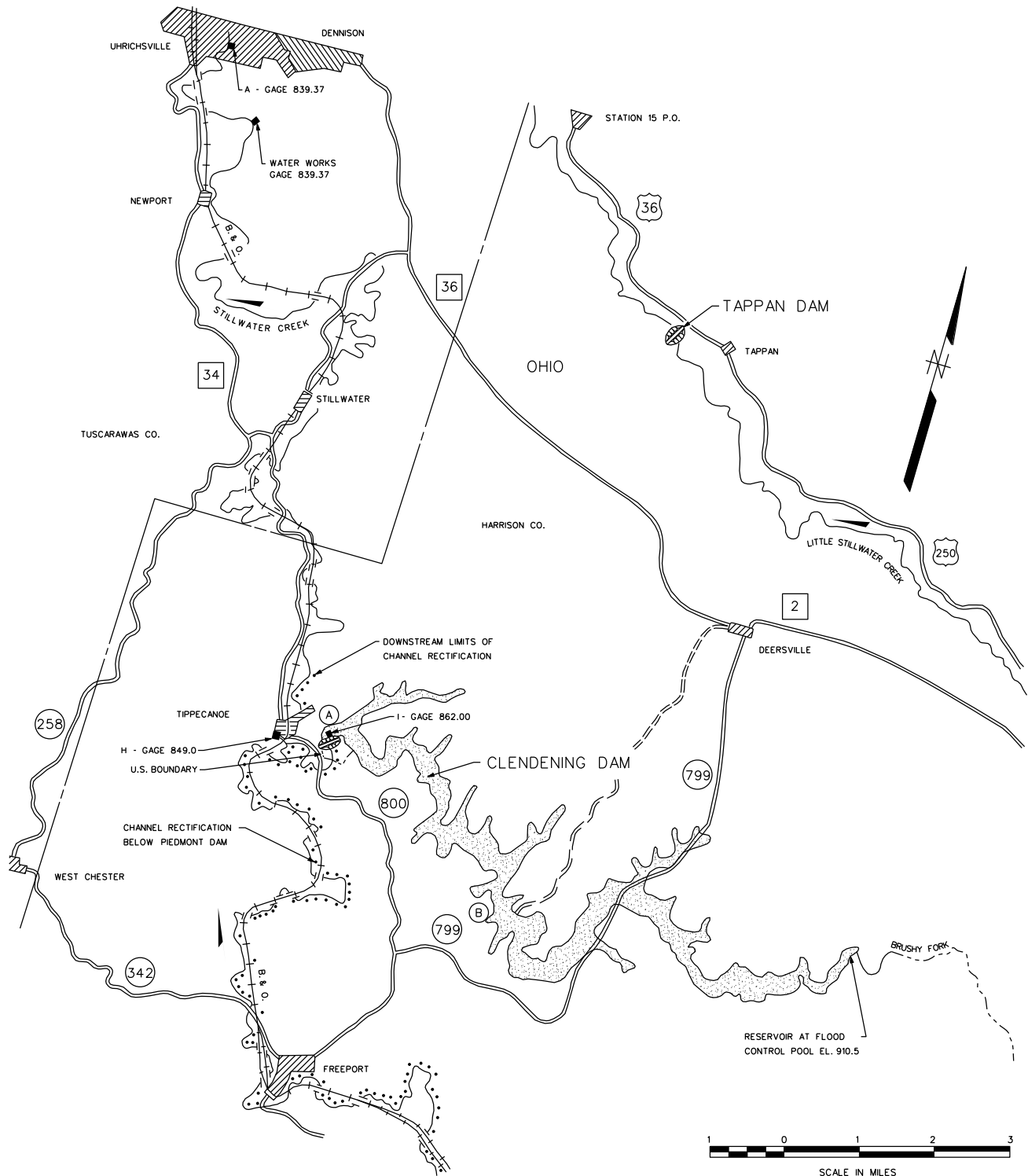

PUBLIC USE GUIDE

- PARKING, RESTROOMS & PICNIC AREA - CORPS OF ENGINEERS (A)
- MARINA, RESTROOMS, CAMPING AREA & MOTEL - M.W.C.D. (B)

BRUSHY FORK
OHIO

CLENDENING DAM

CLENDENING LAKE

DEPARTMENT OF THE ARMY
HUNTINGTON DISTRICT, CORPS OF ENGINEERS
HUNTINGTON, WV REDRAWN MARCH 2005

CLENDENING F/C 7-A

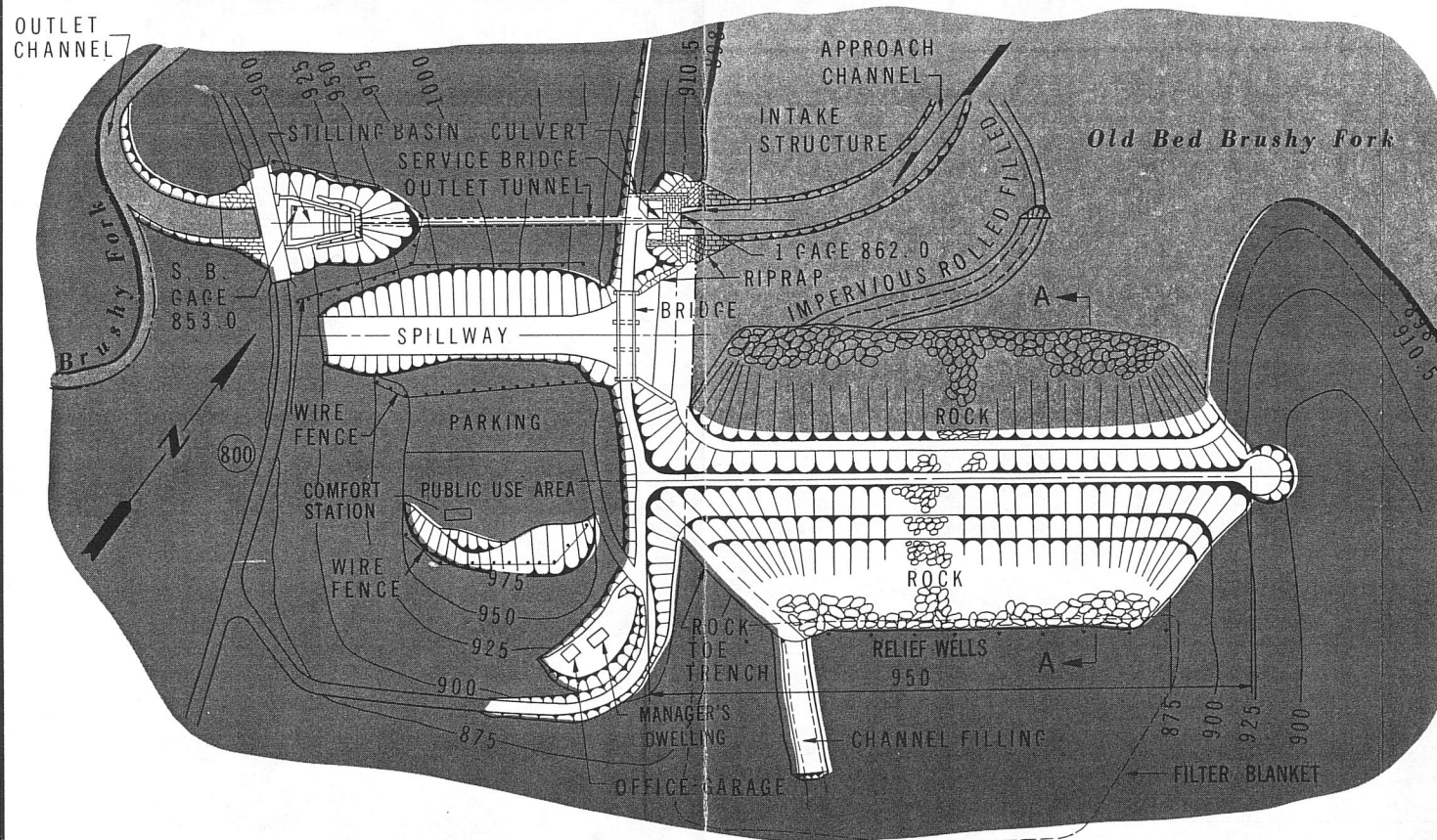
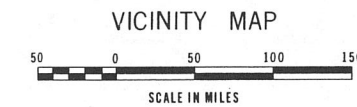

PLAN

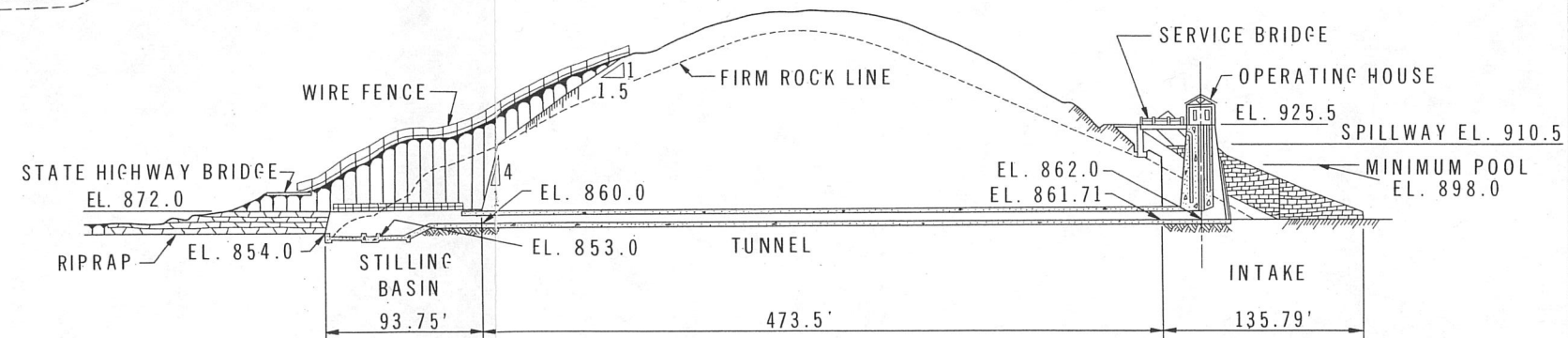
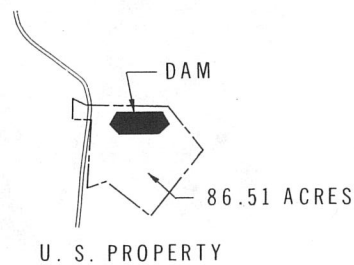
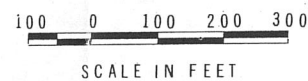

PROFILE ON CENTER LINE OF OUTLET WORKS

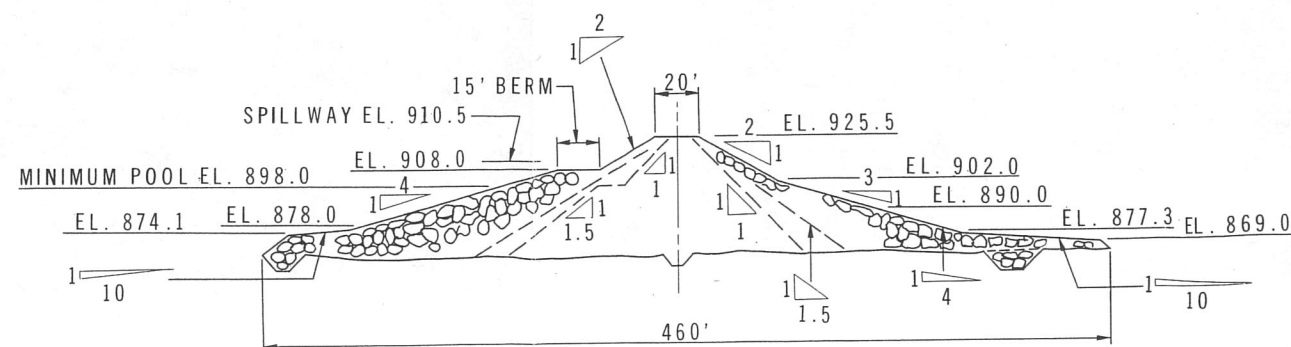

SECTION A - A



MUSKINGUM RIVER
**CLENDENING LAKE
 DAM AND SPILLWAY**
 PLAN, PROFILE AND SECTION
 HUNTINGTON DISTRICT, HUNTINGTON, W. VA.
 Revised : 30 SEPTEMBER 1984

BRUSHY FORK
OHIO

CLENDENING DAM

PLAN AND ELEVATION OF DAM

DEPARTMENT OF THE ARMY
HUNTINGTON DISTRICT, CORPS OF ENGINEERS
HUNTINGTON, WV REDRAWN MARCH 2005

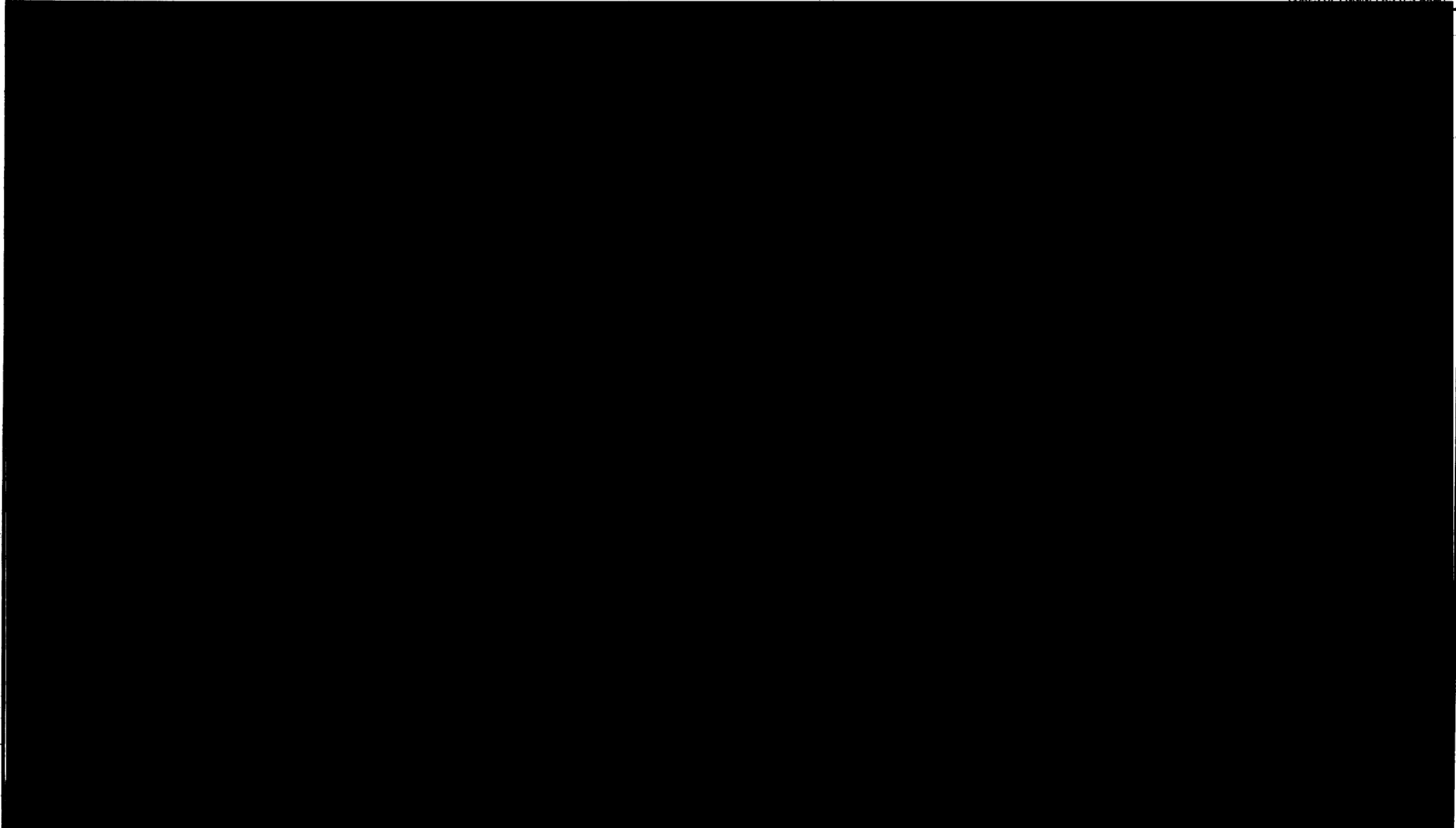

**MUSKINGUM WATERSHED
CLENDENING DAM
BRUSHY FORK
EMBANKMENT DETAILS**

SHEET 7 OF 27 SHEETS SCALES AS SHOWN

U. S. ENGINEER OFFICE, ZANESVILLE, O. DEC. 1934

SUBMITTED: <i>[Signature]</i> <small>ENGINEER CHIEF, PLANNING SECTION</small>	APPROVAL, RECOMMENDED: <i>[Signature]</i> <small>SENIOR ENGINEER CHIEF, ENGINEERING DIVISION</small>	APPROVED: <i>[Signature]</i> <small>MAJOR, CORPS OF ENGINEERS DISTRICT ENGINEER</small>
---	--	---

DESIGNED:
[Signature]
ENGINEER

DR. BY S.R.G. TO ACCOMPANY SPECIFICATIONS
 TR. BY L.H.F. DATED DEC. 1934
 CR. BY L.B.V.

BRUSHY FORK
OHIO

CLENDENING DAM

SPILLWAY

DEPARTMENT OF THE ARMY
HUNTINGTON DISTRICT, CORPS OF ENGINEERS
HUNTINGTON, WV REDRAWN MARCH 2005

BRUSHY FORK
OHIO

CLENDENING DAM

SPILLWAY BRIDGE SUPERSTRUCTURE

DEPARTMENT OF THE ARMY
HUNTINGTON DISTRICT, CORPS OF ENGINEERS
HUNTINGTON, WV REDRAWN MARCH 2005

BRUSHY FORK
OHIO

CLENDENING DAM

OUTLET WORKS AND TUNNEL SECTION

DEPARTMENT OF THE ARMY
HUNTINGTON DISTRICT, CORPS OF ENGINEERS
HUNTINGTON, WV REDRAWN MARCH 2005

BRUSHY FORK
OHIO

CLENDENING DAM

OPERATING HOUSE

DEPARTMENT OF THE ARMY
HUNTINGTON DISTRICT, CORPS OF ENGINEERS
HUNTINGTON, WV REDRAWN MARCH 2005

BRUSHY FORK
OHIO

CLENDENING DAM

INTAKE - PLAN AND ELEVATIONS

DEPARTMENT OF THE ARMY
HUNTINGTON DISTRICT, CORPS OF ENGINEERS
HUNTINGTON, WV REDRAWN MARCH 2005

BRUSHY FORK
OHIO

CLENDENING DAM

INTAKE - PLAN AND SECTIONS

DEPARTMENT OF THE ARMY
HUNTINGTON DISTRICT, CORPS OF ENGINEERS
HUNTINGTON, WV REDRAWN MARCH 2005

BRUSHY FORK
OHIO

CLENDENING DAM

INTAKE - TRANSITION

DEPARTMENT OF THE ARMY
HUNTINGTON DISTRICT, CORPS OF ENGINEERS
HUNTINGTON, WV REDRAWN MARCH 2005

BRUSHY FORK
OHIO

CLENDENING DAM

INTAKE - DETAILS AND SERVICE BRIDGE

DEPARTMENT OF THE ARMY
HUNTINGTON DISTRICT, CORPS OF ENGINEERS
HUNTINGTON, WV REDRAWN MARCH 2005

BRUSHY FORK
OHIO

CLENDENING DAM

STILLING BASIN

DEPARTMENT OF THE ARMY
HUNTINGTON DISTRICT, CORPS OF ENGINEERS
HUNTINGTON, WV REDRAWN MARCH 2005

BRUSHY FORK
OHIO

CLENDENING DAM

STILLING BASIN - SECTIONS

DEPARTMENT OF THE ARMY
HUNTINGTON DISTRICT, CORPS OF ENGINEERS
HUNTINGTON, WV REDRAWN MARCH 2005

- LEGEND**
- STATE ROUTES
 - COUNTY ROADS
 - TOWNSHIP ROADS
 - UNIMPROVED ROADS OR DRIVES, TRAILS OR LINES
 - RAILROADS
 - M.W.C.D. PROPERTY LINES

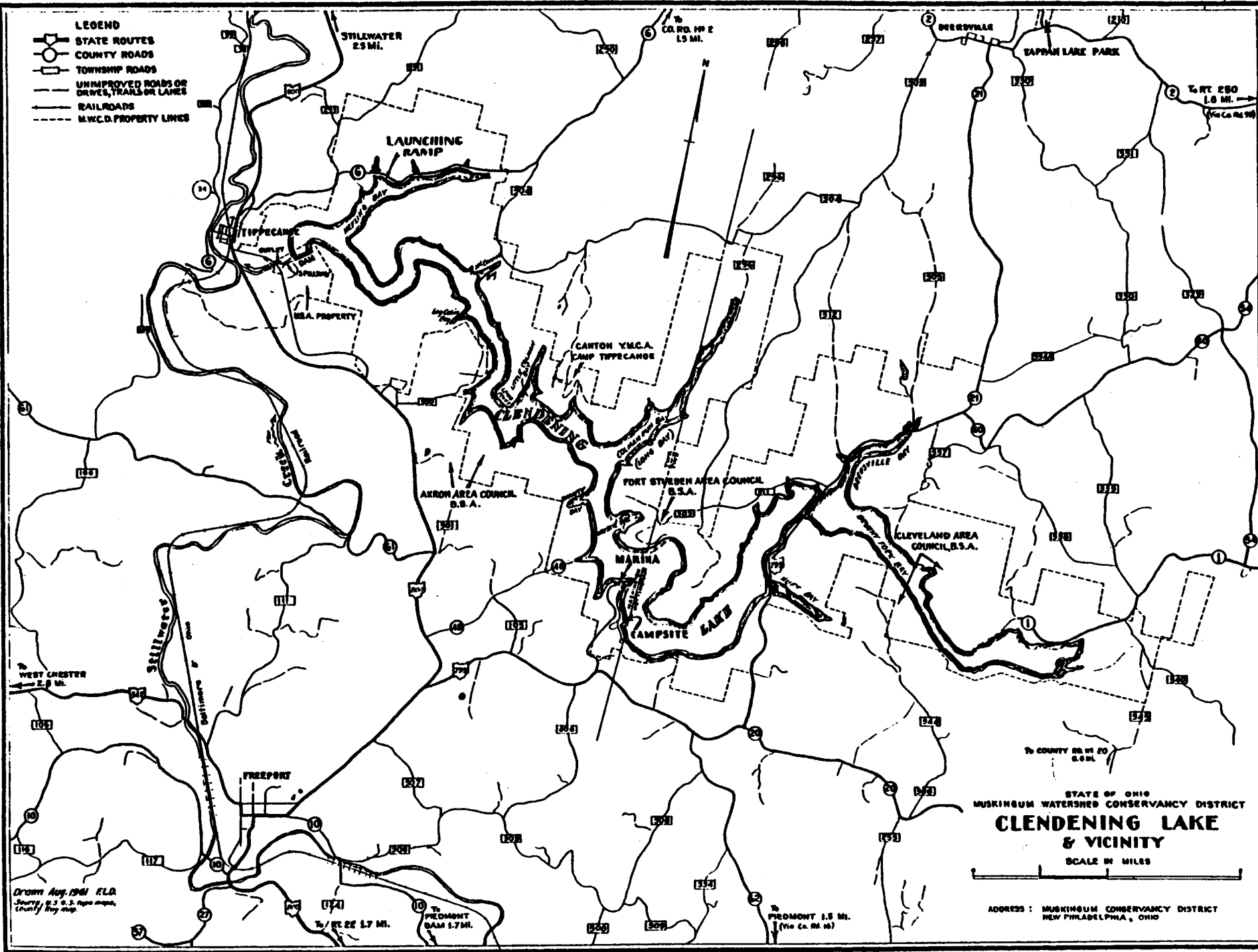

STATE OF OHIO
 MUSKINGUM WATERSHED CONSERVANCY DISTRICT
CLENDENING LAKE & VICINITY
 SCALE IN MILES

ADDRESS: MUSKINGUM CONSERVANCY DISTRICT
 NEW PHILADELPHIA, OHIO

Drawn Aug. 1941 F.L.D.
 Source: U.S.G.S. Topographic
 County Map

Plate No. 2-17

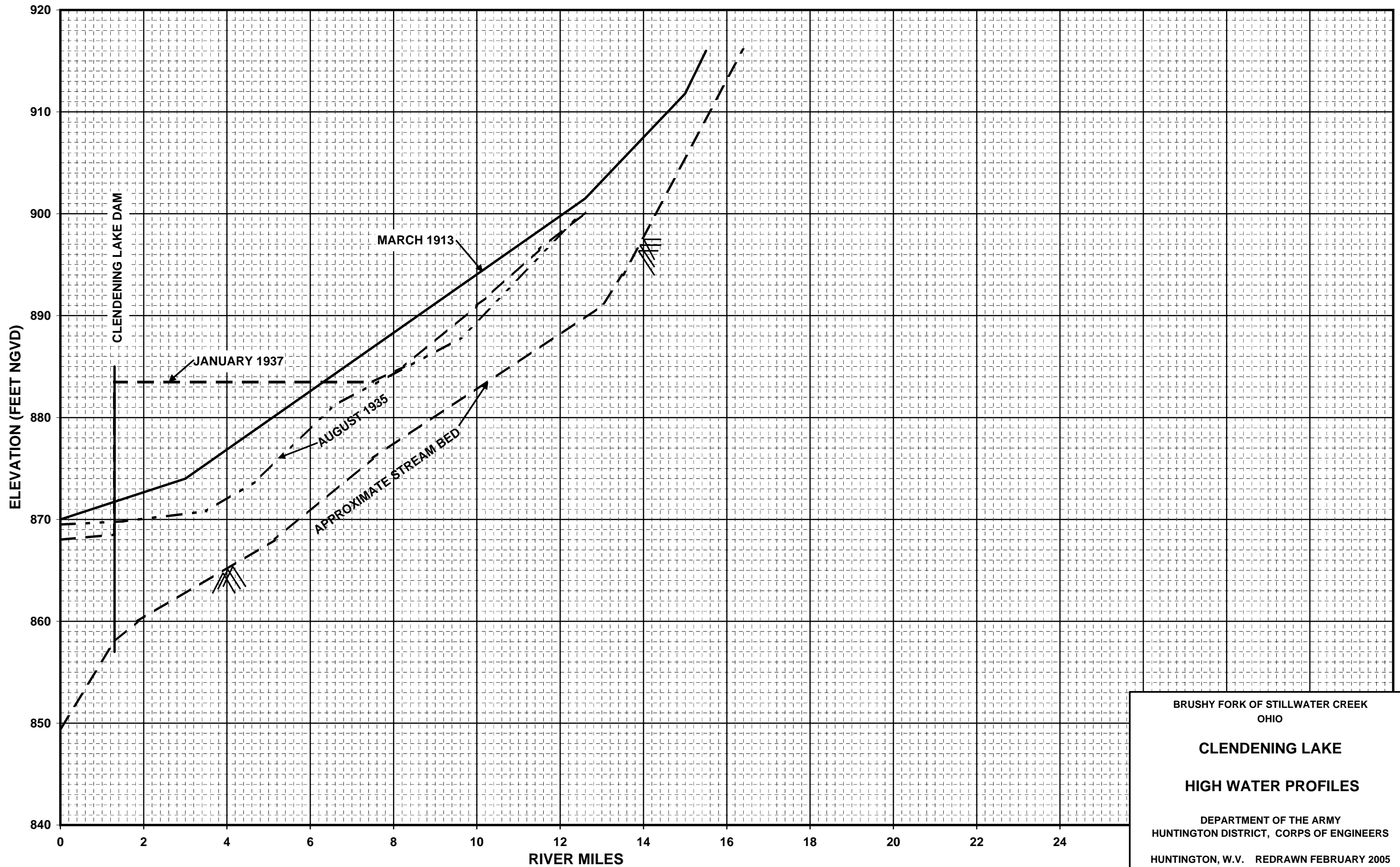

BRUSHY FORK OF STILLWATER CREEK
OHIO

CLENDENING LAKE

HIGH WATER PROFILES

DEPARTMENT OF THE ARMY
HUNTINGTON DISTRICT, CORPS OF ENGINEERS
HUNTINGTON, W.V. REDRAWN FEBRUARY 2005

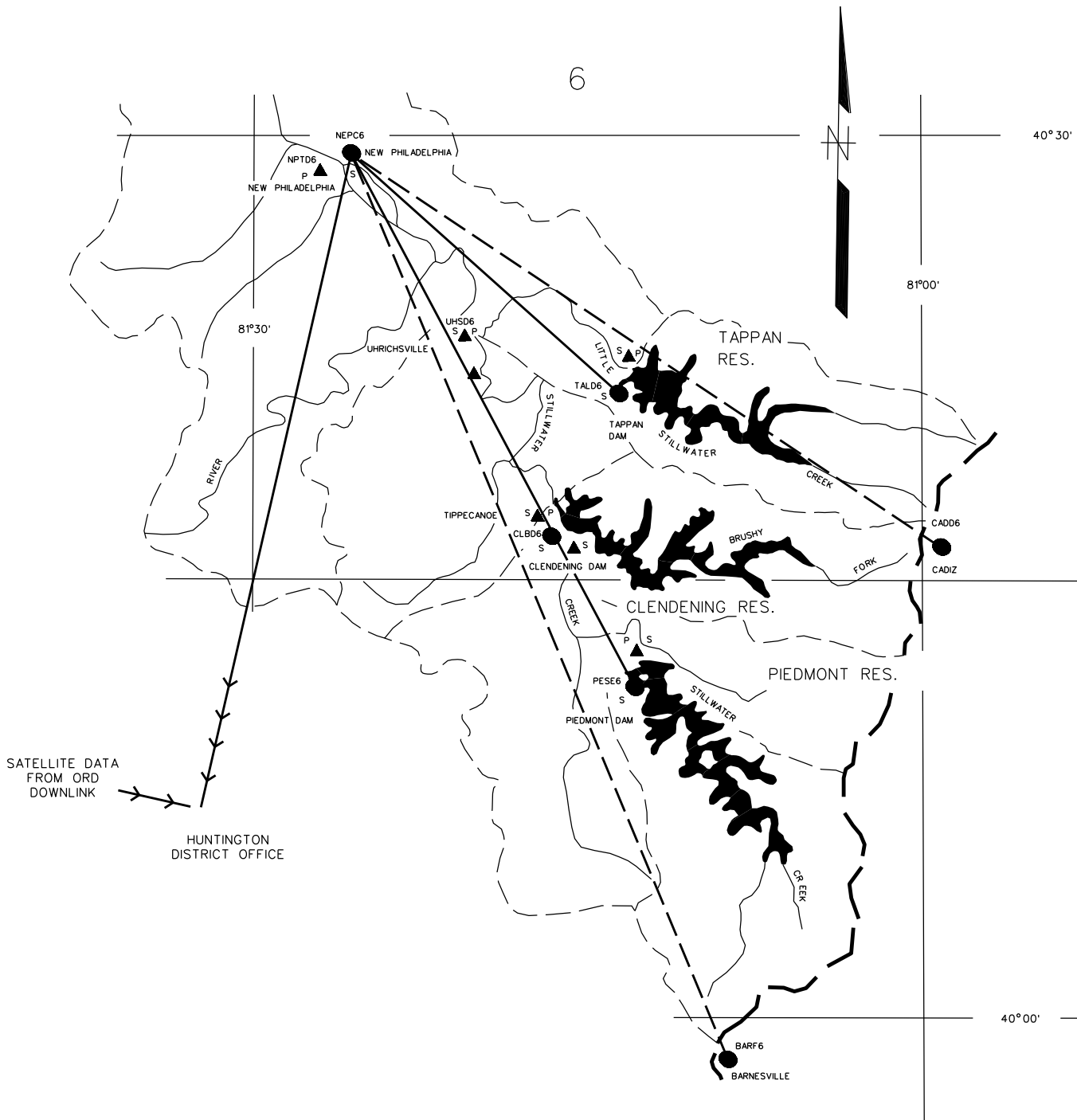

- LEGEND**
- WATERSHED BOUNDARY LINE
 - RESERVOIR SPILLWAY ELEVATION
 - REPORTING PRECIPITATION STATION
 - PRECIPITATION
 - STAGE
 - SATELLITE DATA PLATFORM
 - SATELLITE DATA PLATFORM PLANNED
 - TELEPHONE AND RADIO BACKUP
 - TELEPHONE OBSERVERS

BRUSHY FORK
OHIO

CLENDENING LAKE

HYDROLOGIC NETWORK

DEPARTMENT OF THE ARMY
HUNTINGTON DISTRICT, CORPS OF ENGINEERS
HUNTINGTON, WV REDRAWN MARCH 2005

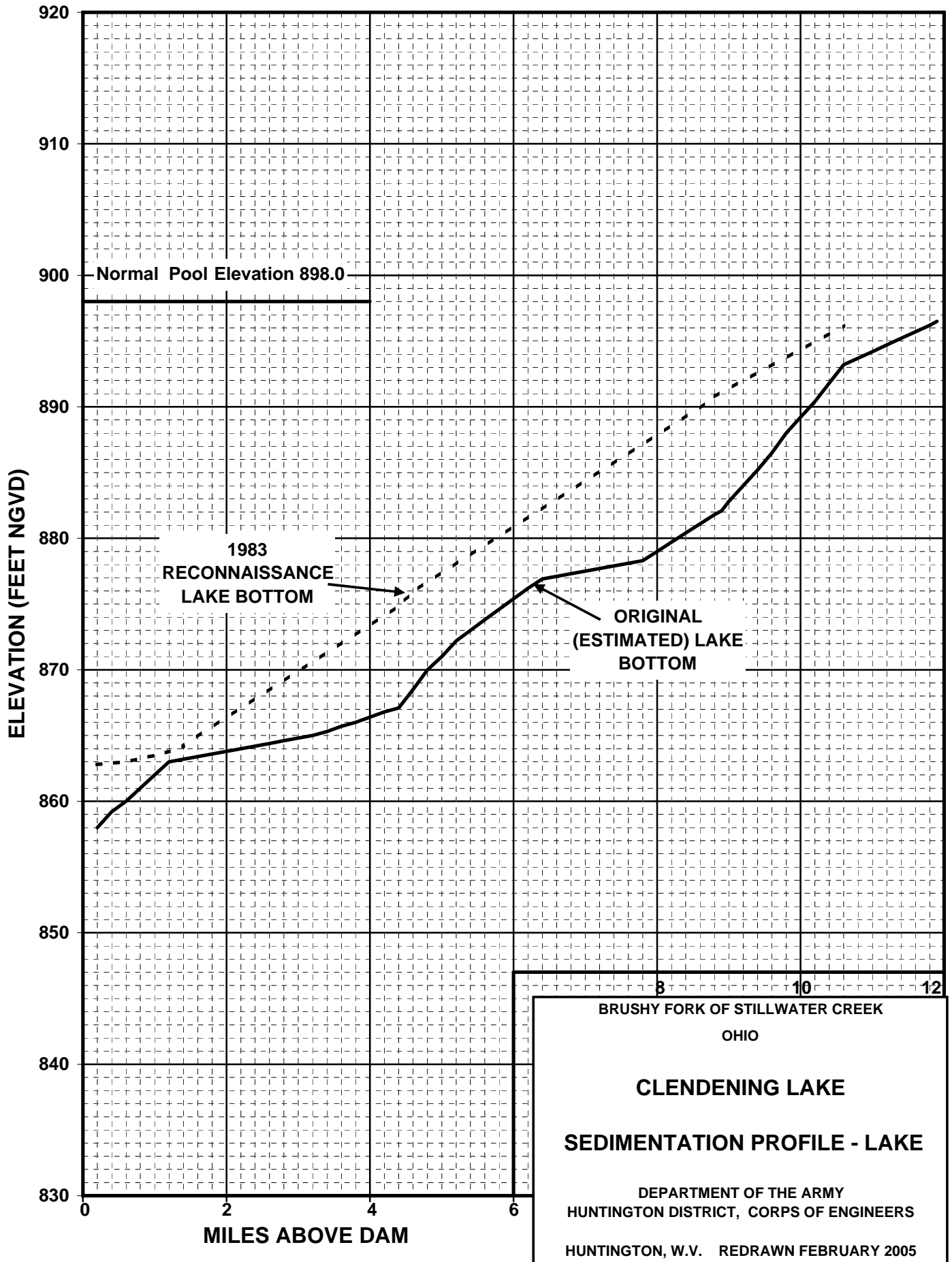

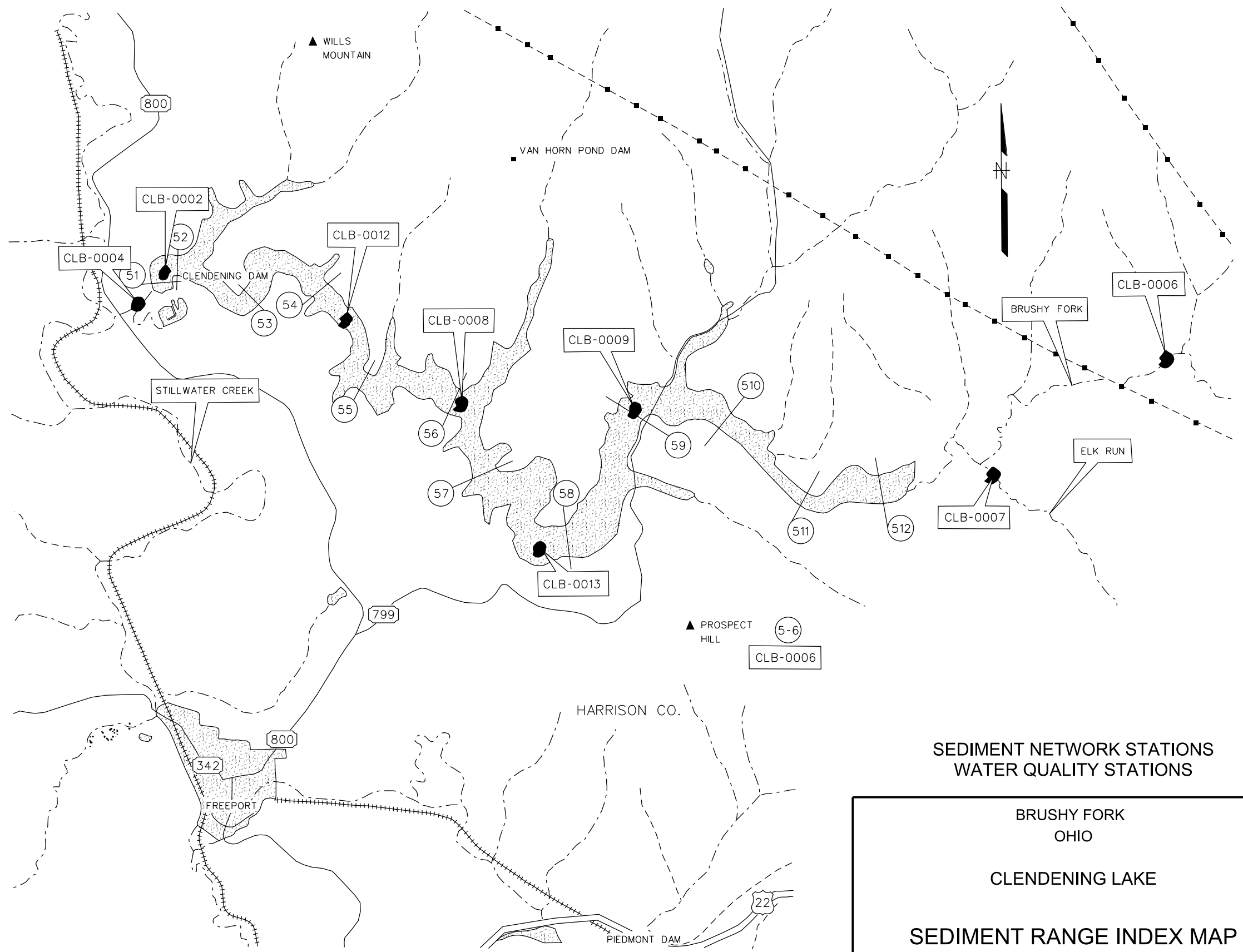

SEDIMENT NETWORK STATIONS
 WATER QUALITY STATIONS

BRUSHY FORK
 OHIO

CLENDENING LAKE

SEDIMENT RANGE INDEX MAP

DEPARTMENT OF THE ARMY
 HUNTINGTON DISTRICT, CORPS OF ENGINEERS
 HUNTINGTON, WV REDRAWN MARCH 2005

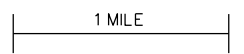
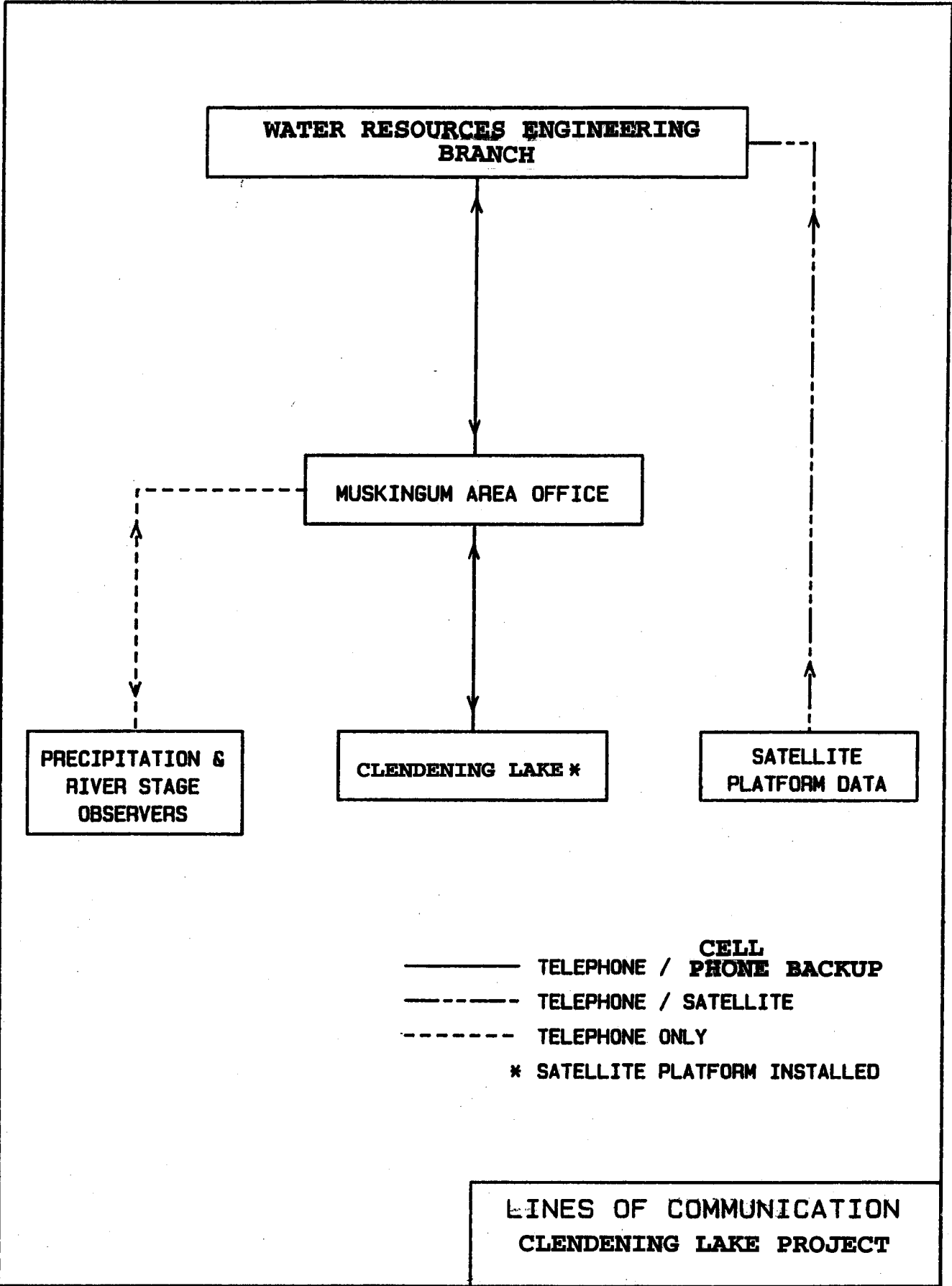

PLATE NO. 5-3



Mail to: Ohio River Division
ATTN: ORDED-WR

RECORD OF DEVIATION FROM APPROVED
WATER CONTROL PLAN

DATE _____

DEVIATION _____
(Lake, Reservoir, or System)

1. This is to confirm the following verbal request from

_____ to _____ via
(Name) (Office Symbol) (Name) (Office Symbol)

telephone for approval of a deviation from the approved water control
plan.

2. _____

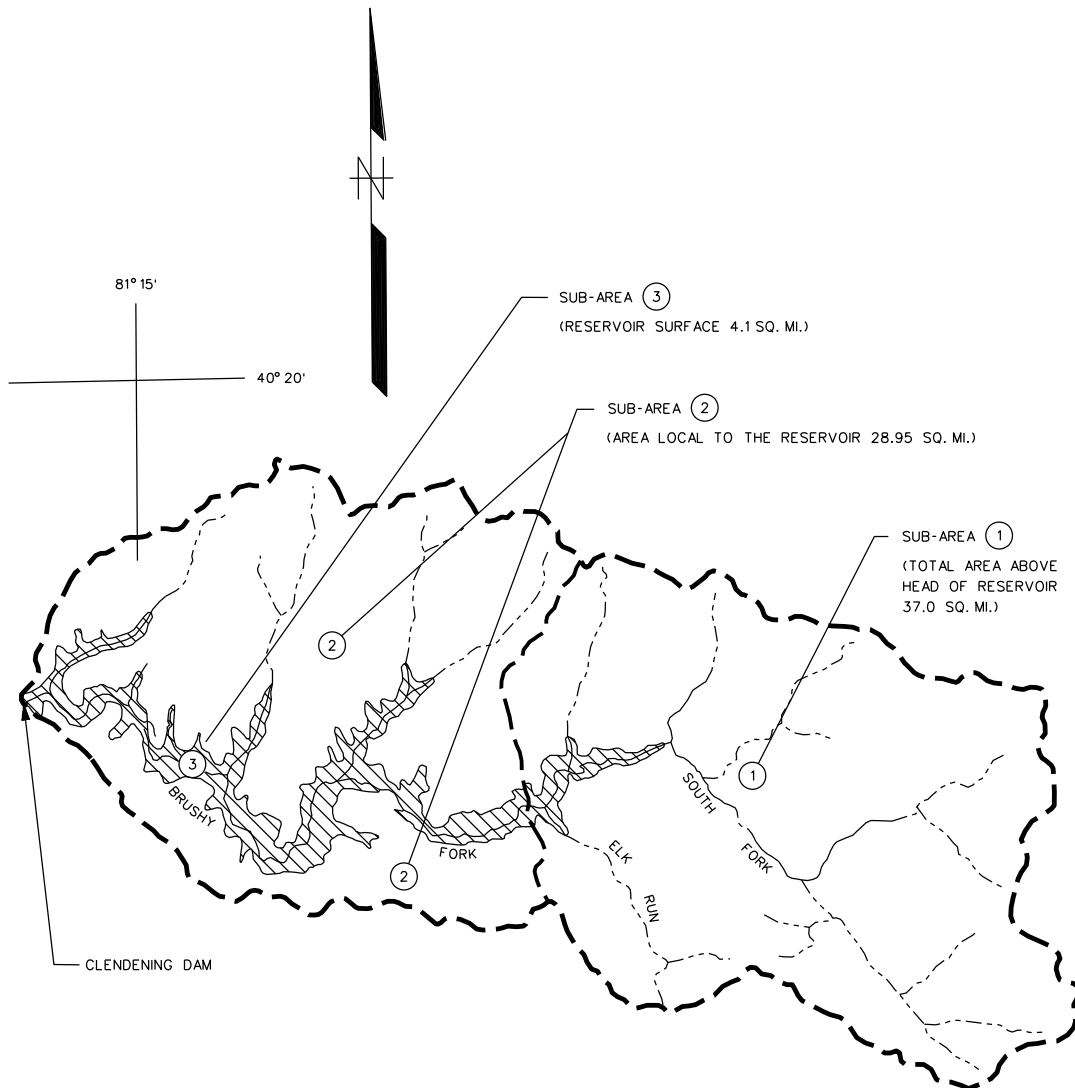

LOCATION MAP

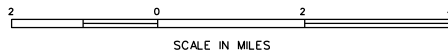

BRUSH FORK
OHIO

CLENDENING LAKE

FORECAST AREA REACHES

DEPARTMENT OF THE ARMY
HUNTINGTON DISTRICT, CORPS OF ENGINEERS
HUNTINGTON, WV REDRAWN MARCH 2005

CLDENING LAKE
MUSKINGUM RIVER BASIN

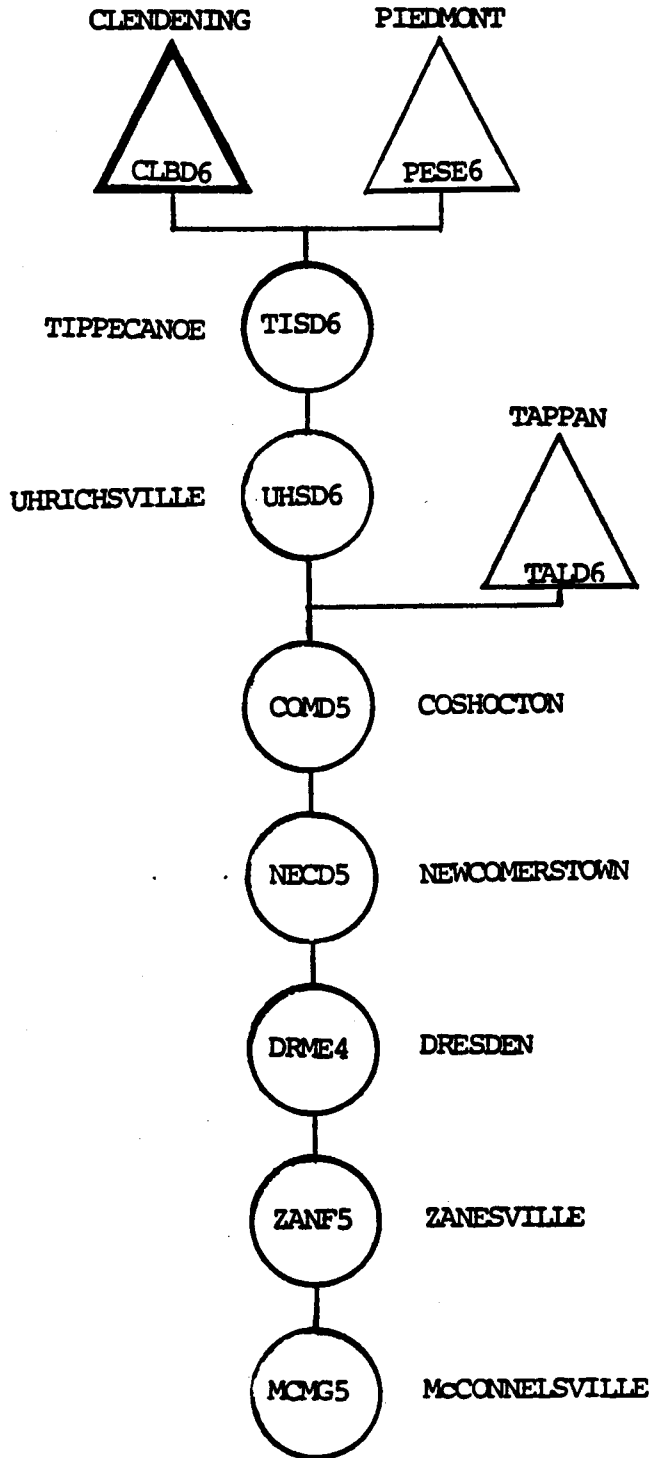

CLENDENING LAKE
BRUSHY FORK
AREA AND CAPACITY TABLES

DRAINAGE AREA = 69 SQ. MI.

1 IN. RUNOFF = 3678 AC. FT.

POOL ELEV.	CAPACITY		AREA IN ACRES	POOL ELEV.	CAPACITY		AREA IN ACRES
	AC. FT.	INCHES			AC. FT.	INCHES	
855.0	0	0.00	0	889.0	13300	3.62	1170
856.0	0	0.00	0	890.0	14500	3.94	1230
857.0	0	0.00	1	891.0	15700	4.27	1300
858.0	2	0.00	3	892.0	17100	4.65	1360
859.0	6	0.00	4	893.0	18500	5.03	1430
860.0	10	0.00	5	894.0	19900	5.41	1500
861.0	16	0.00	8	895.0	21500	5.85	1580
862.0	27	0.01	14	896.0	23100	6.28	1660
863.0	45	0.01	23	897.0	24800	6.74	1730
864.0	75	0.02	36	898.0	26500	7.21	1800
865.0	123	0.03	60	899.0	28400	7.72	1870
866.0	201	0.05	96	900.0	30300	8.24	1920
867.0	315	0.09	131	901.0	32200	8.75	1990
868.0	463	0.13	166	902.0	34200	9.30	2040
869.0	647	0.18	201	903.0	36300	9.87	2100
870.0	865	0.24	236	904.0	38400	10.44	2160
871.0	1120	0.30	268	905.0	40600	11.04	2230
872.0	1400	0.38	304	906.0	42900	11.66	2300
873.0	1720	0.47	338	907.0	45200	12.29	2380
874.0	2080	0.57	373	908.0	47600	12.94	2450
875.0	2470	0.67	407	909.0	50100	13.62	2520
876.0	2900	0.79	447	910.0	52700	14.33	2590
877.0	3360	0.91	490	910.5	54000	14.68	2620
878.0	3880	1.05	539	911.0	55300	15.04	2650
879.0	4440	1.21	591	912.0	58000	15.77	2720
880.0	5060	1.38	648	913.0	60700	16.50	2790
881.0	5740	1.56	706	914.0	63600	17.29	2860
882.0	6480	1.76	766	915.0	66500	18.08	2930
883.0	7270	1.98	826	916.0	69400	18.87	3000
884.0	8130	2.21	885	917.0	72500	19.71	3070
885.0	9040	2.46	944	918.0	75600	20.55	3150
886.0	10000	2.72	1000	919.0	78800	21.42	3220
887.0	11000	2.99	1050	920.0	82000	22.29	3300
888.0	12100	3.29	1110	921.0	85300	23.19	3370
				922.0	88700	24.12	3450

CLDENING LAKE

PERCENT STORAGE UTILIZATION - WINTER

ELEV	.0	.1	.2	.3	.4	.5	.6	.7	.8	.9
893	0.00	0.37	0.74	1.12	1.51	1.90	2.30	2.70	3.11	3.52
894	3.94	4.39	4.85	5.30	5.75	6.20	6.65	7.10	7.55	8.00
895	8.45	8.89	9.33	9.77	10.22	10.67	11.12	11.58	12.03	12.49
896	12.96	13.44	13.92	14.39	14.87	15.35	15.83	16.31	16.79	17.27
897	17.75	18.20	18.66	19.12	19.59	20.07	20.55	21.04	21.53	22.03
898	22.54	23.07	23.61	24.14	24.68	25.21	25.75	26.28	26.82	27.35
899	27.89	28.42	28.96	29.49	30.03	30.56	31.10	31.63	32.17	32.70
900	33.24	33.76	34.29	34.82	35.35	35.88	36.42	36.96	37.50	38.04
901	38.59	39.14	39.70	40.25	40.81	41.37	41.94	42.51	43.08	43.65
902	44.23	44.82	45.41	46.00	46.59	47.18	47.77	48.37	48.96	49.55
903	50.14	50.72	51.30	51.89	52.47	53.06	53.66	54.25	54.85	55.45
904	56.06	56.66	57.27	57.89	58.50	59.12	59.74	60.37	60.99	61.62
905	62.25	62.90	63.55	64.20	64.85	65.49	66.14	66.79	67.44	68.08
906	68.73	69.37	70.01	70.65	71.29	71.94	72.59	73.24	73.89	74.55
907	75.21	75.88	76.54	77.21	77.88	78.56	79.23	79.91	80.60	81.28
908	81.97	82.66	83.36	84.06	84.76	85.46	86.16	86.87	87.58	88.30
909	89.01	89.75	90.48	91.21	91.94	92.68	93.41	94.14	94.87	95.61
910	96.34	97.06	97.78	98.51	99.23	99.97	100.70	0.00	0.00	0.00

CLENDENING LAKE

PERCENT STORAGE UTILIZATION - SUMMER

ELEV	.0	.1	.2	.3	.4	.5	.6	.7	.8	.9
898	0.00	0.69	1.38	2.07	2.76	3.45	4.15	4.84	5.53	6.22
899	6.91	7.60	8.29	8.98	9.67	10.36	11.05	11.75	12.44	13.13
900	13.82	14.49	15.17	15.85	16.54	17.23	17.92	18.62	19.32	20.02
901	20.73	21.44	22.15	22.87	23.59	24.32	25.05	25.78	26.52	27.26
902	28.00	28.76	29.53	30.29	31.05	31.82	32.58	33.35	34.11	34.87
903	35.64	36.38	37.13	37.89	38.65	39.41	40.17	40.94	41.72	42.49
904	43.27	44.06	44.84	45.63	46.43	47.23	48.03	48.83	49.64	50.46
905	51.27	52.11	52.95	53.78	54.62	55.45	56.29	57.13	57.96	58.80
906	59.64	60.46	61.28	62.11	62.94	63.77	64.61	65.45	66.30	67.15
907	68.00	68.86	69.72	70.58	71.45	72.32	73.19	74.07	74.95	75.84
908	76.73	77.62	78.52	79.42	80.32	81.23	82.14	83.05	83.97	84.89
909	85.82	86.76	87.71	88.65	89.60	90.55	91.49	92.44	93.38	94.33
910	95.27	96.20	97.13	98.07	99.01	99.95	100.90	0.00	0.00	0.00

CLENDENING LAKE

SIPHON RATING

Pool Elev.	.00	.01	.02	.03	.04	.05	.06	.07	.08	.09
897.0										
897.1										
897.2										
897.3										
897.4										
897.5										
897.6										
897.7	10	10	10	10	11	12	13	15	17	19
897.8	22	25	28	32	36	40	44	47	50	52
897.9	54	56	58	60	62	63	65	66	67	69
898.0	70	71	72	73	75	76	77	78	79	80
898.1	81	82	83	84	85	86	87	88	89	90
898.2	91	92	92	93	94	95	96	97	98	98
898.3	99	100	101	102	102	103	104	105	106	106
898.4	107	108	109	109	110	111	112	112	113	113
898.5	114	115	115	116	116	117	117	118	119	119
898.6	119	120	120	121	121	122	122	123	124	124
898.7	124	125	125	126	126	127	127	128	129	129
898.8	130	131	131	132	132	133	133	134	135	135
898.9	135	136	136	137	137	137	137	138	139	139
899.0	140									

DISCHARGES IN CFS

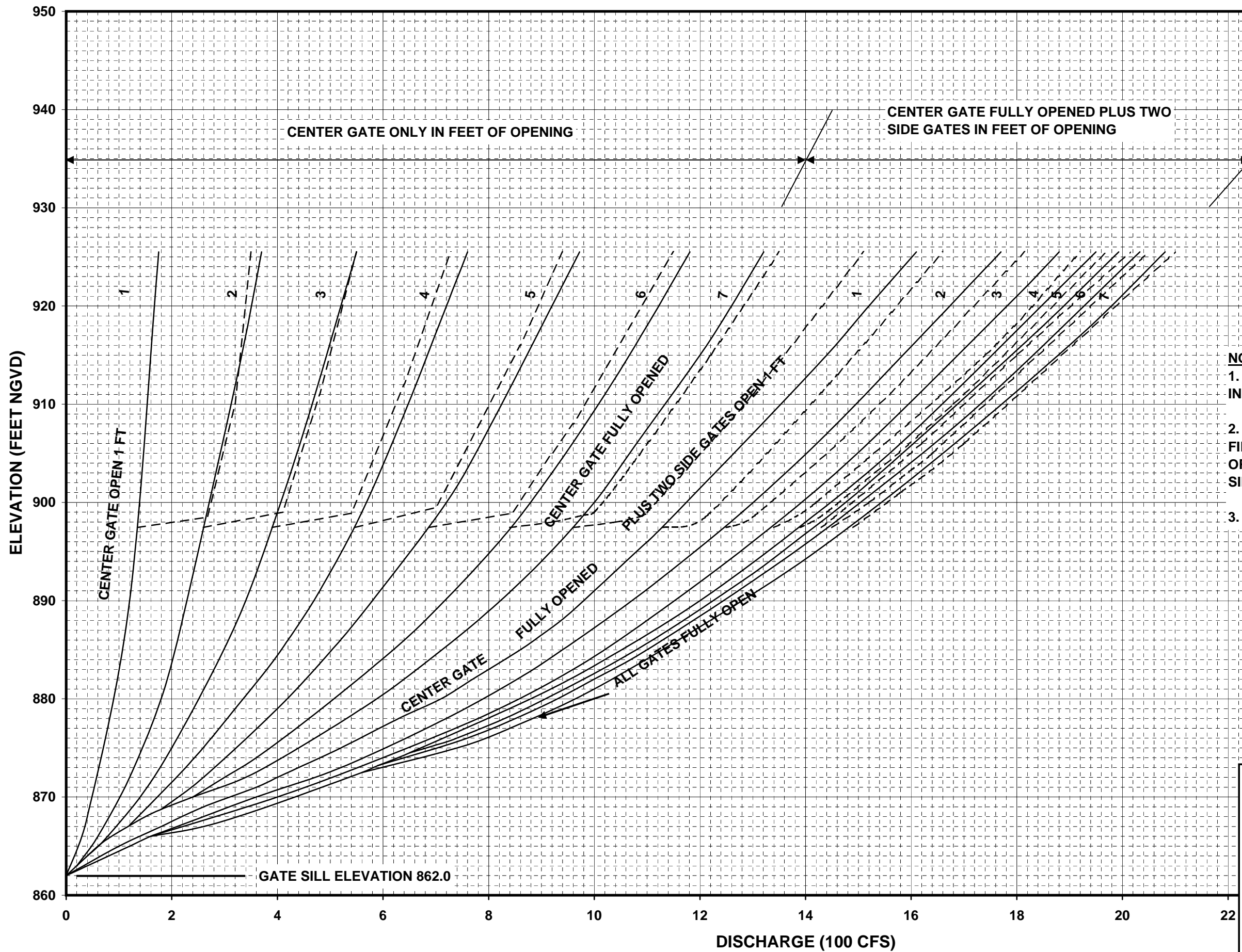

- NOTES**
1. DASHED LINES ABOVE EL. 897.45 INCLUDE SIPHON DISCHARGE.
 2. THE CENTER GATE IS ALWAYS OPENED FIRST AND WHEN IT IS FULLY OPENED, OPERATE THE TWO SIDE GATES SIMULTANEOUSLY .
 3. SPILLWAY CREST EL. 910.5.

BRUSHY FORK OF STILLWATER CREEK
OHIO

CLENDENING LAKE

GATE RATING CURVES

DEPARTMENT OF THE ARMY
HUNTINGTON DISTRICT, CORPS OF ENGINEERS

HUNTINGTON, W.V. REDRAWN FEBRUARY 2005

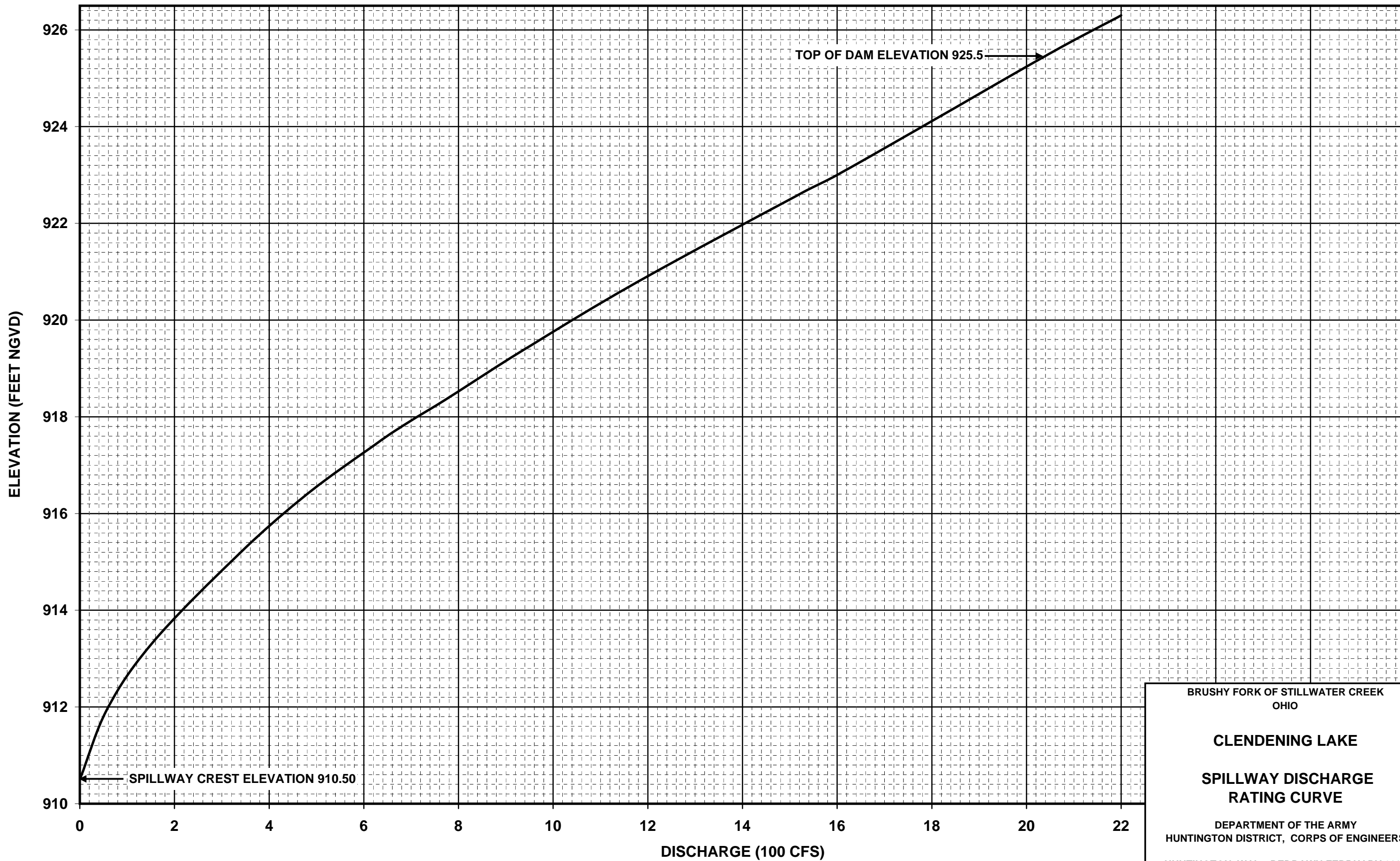

BRUSHY FORK OF STILLWATER CREEK
OHIO

CLENDENING LAKE

**SPILLWAY DISCHARGE
RATING CURVE**

DEPARTMENT OF THE ARMY
HUNTINGTON DISTRICT, CORPS OF ENGINEERS

HUNTINGTON, W.V. REDRAWN FEBRUARY 2005

JANUARY FEBRUARY MARCH APRIL MAY JUNE JULY AUGUST SEPTEMBER OCTOBER NOVEMBER DECEMBER

5 10 15 20 25 5 10 15 20 25 5 10 15 20 25 5 10 15 20 25 5 10 15 20 25 5 10 15 20 25 5 10 15 20 25 5 10 15 20 25 5 10 15 20 25 5 10 15 20 25 5 10 15 20 25

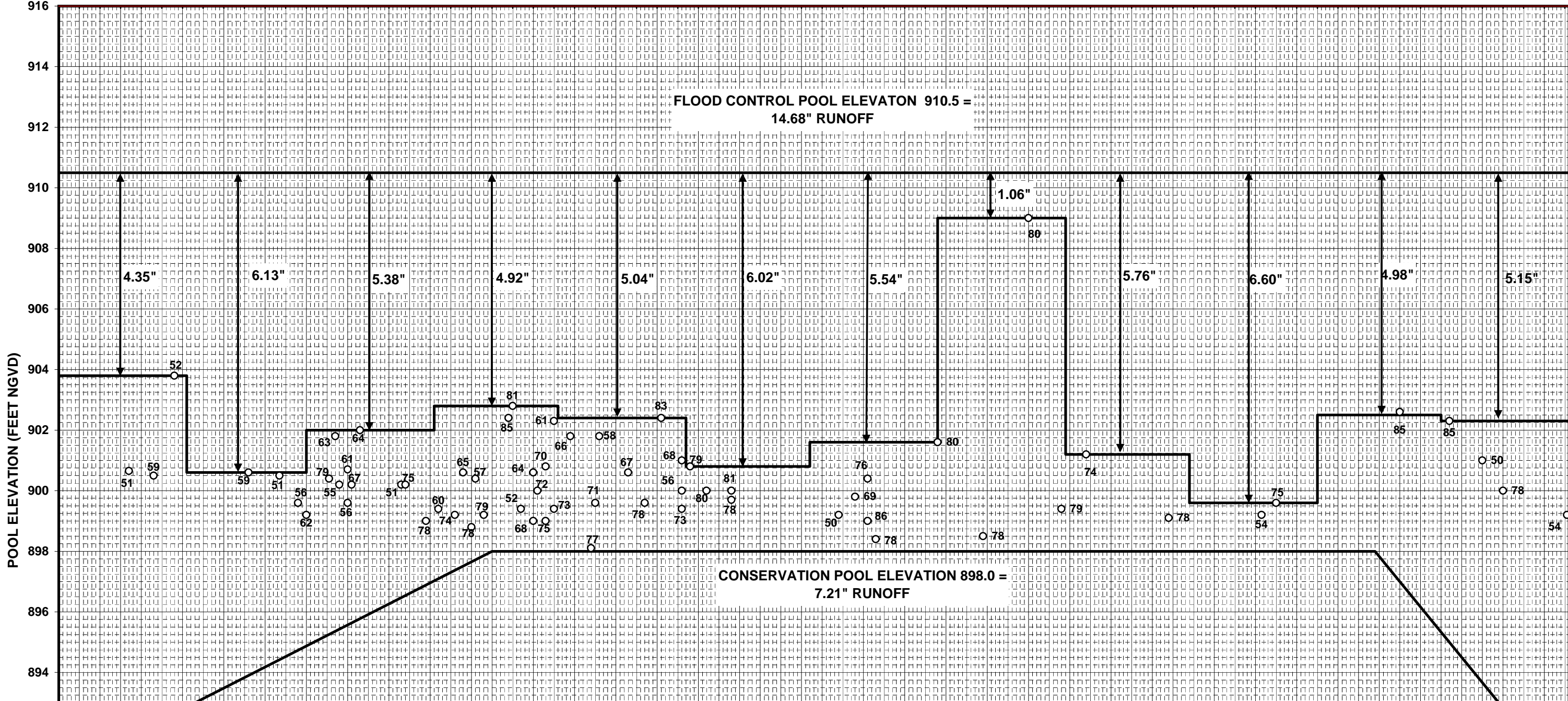

FLOOD CONTROL POOL ELEVATION 910.5 =
14.68" RUNOFF

CONSERVATION POOL ELEVATION 898.0 =
7.21" RUNOFF

NORMAL DESIGNATED MINIMUM POOL
ELEVATION 893.0 = 5.03" RUNOFF

POOL ELEVATION (FEET NGVD)

- NOTES:**
- 1) DRAINAGE AREA = 69 SQ. MI.
 - 2) ONE INCH RUNOFF = 3678 AC. FT.
 - 3) PERIOD OF RECORD: 1950 - 1986
 - 4) CREST POOL ELEVATION OF A RISE & YEAR (1940) IN WHICH IT OCCURRED

BRUSHY FORK OF STILLWATER CREEK
OHIO

CLENDENING LAKE

LAKE UTILIZATION

DEPARTMENT OF THE ARMY
HUNTINGTON DISTRICT, CORPS OF ENGINEERS

HUNTINGTON, W.V. REDRAWN FEBRUARY 2005

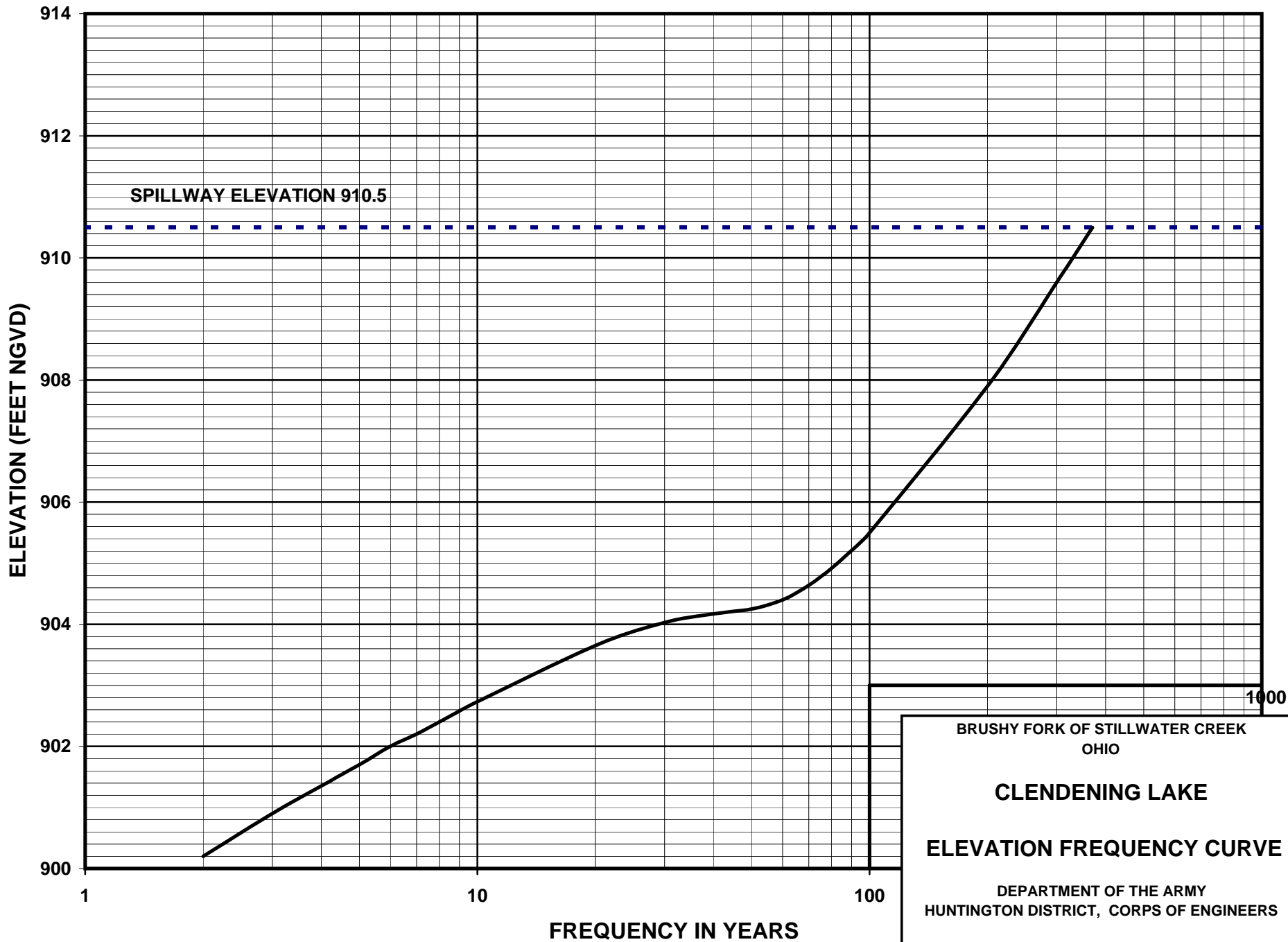

BRUSHY FORK OF STILLWATER CREEK
OHIO

CLENDING LAKE

ELEVATION FREQUENCY CURVE

DEPARTMENT OF THE ARMY
HUNTINGTON DISTRICT, CORPS OF ENGINEERS
HUNTINGTON, W.V. REDRAWN FEBRUARY 2005

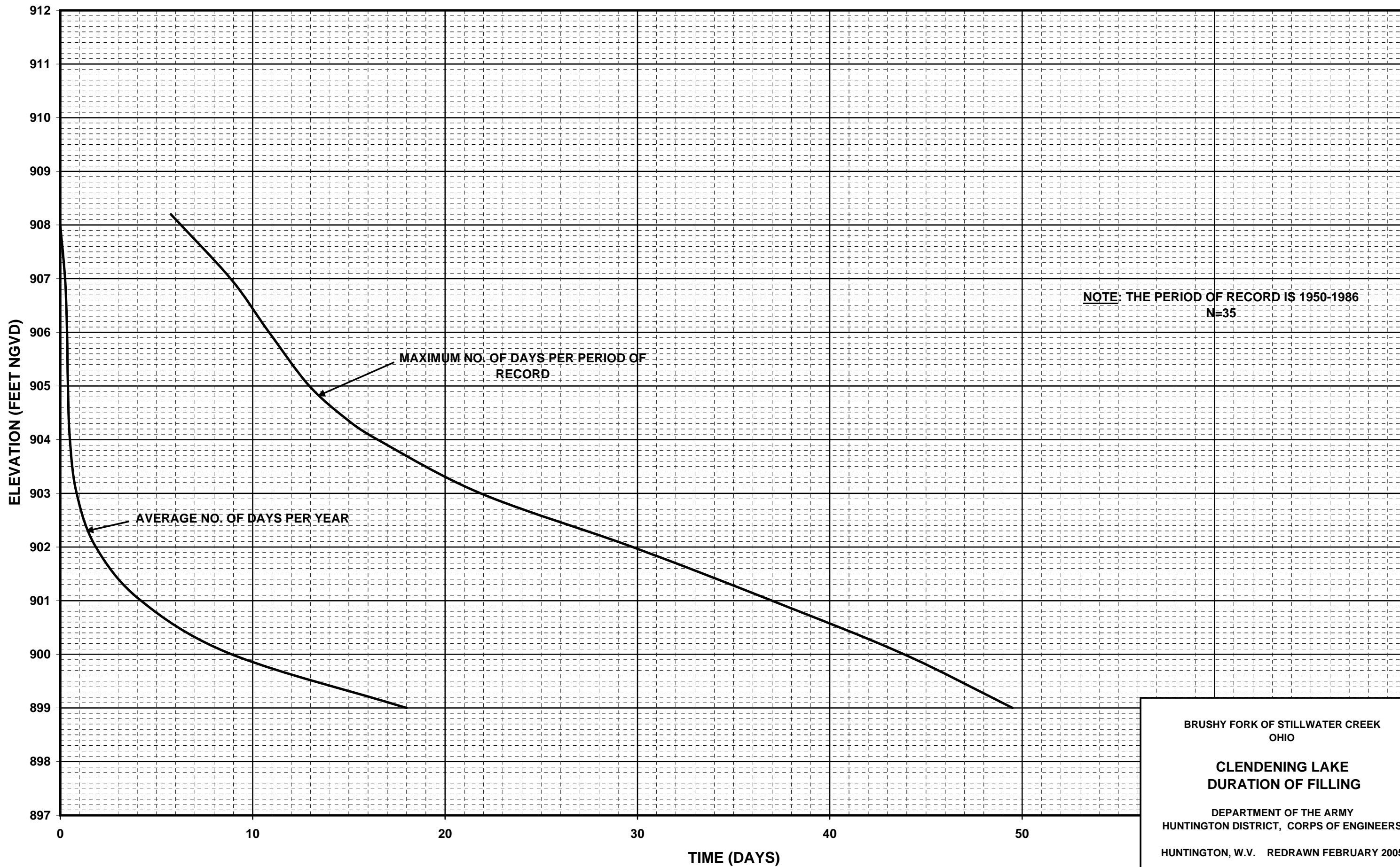

BRUSHY FORK OF STILLWATER CREEK
OHIO

**CLENDENING LAKE
DURATION OF FILLING**

DEPARTMENT OF THE ARMY
HUNTINGTON DISTRICT, CORPS OF ENGINEERS

HUNTINGTON, W.V. REDRAWN FEBRUARY 2005

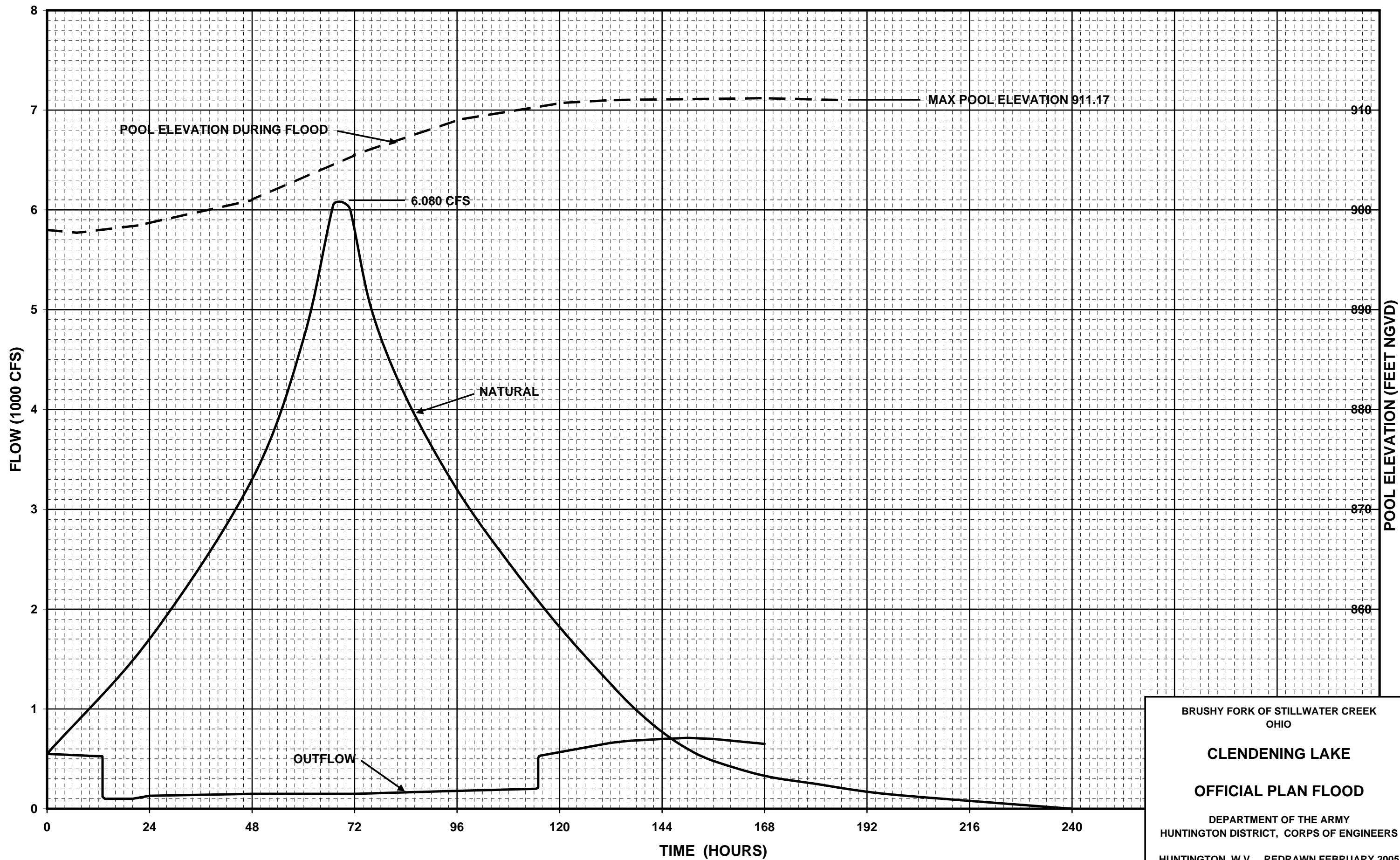

BRUSHY FORK OF STILLWATER CREEK
OHIO

CLENDENING LAKE

OFFICIAL PLAN FLOOD

DEPARTMENT OF THE ARMY
HUNTINGTON DISTRICT, CORPS OF ENGINEERS

HUNTINGTON, W.V. REDRAWN FEBRUARY 2005

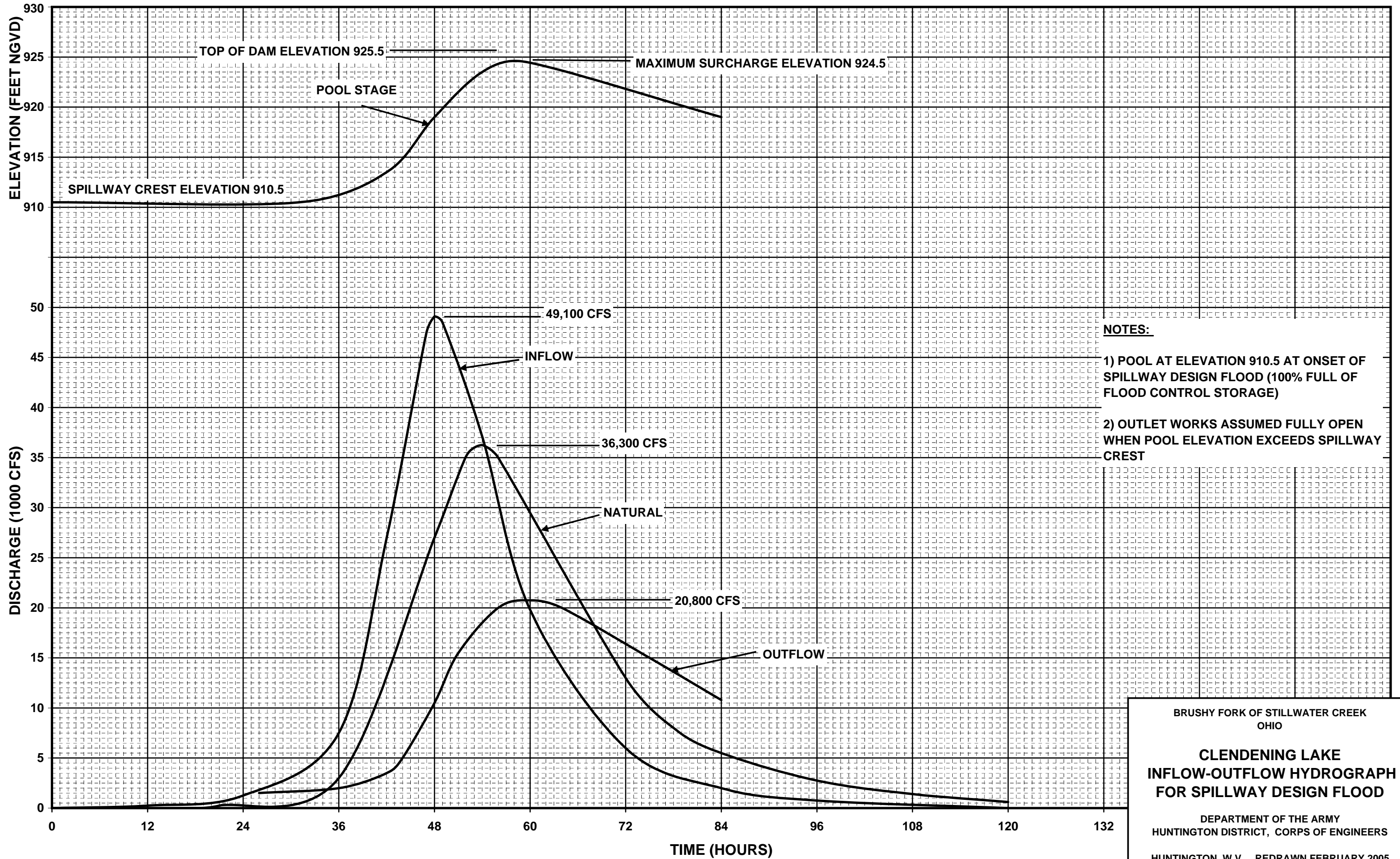

- NOTES:**
- 1) POOL AT ELEVATION 910.5 AT ONSET OF SPILLWAY DESIGN FLOOD (100% FULL OF FLOOD CONTROL STORAGE)
 - 2) OUTLET WORKS ASSUMED FULLY OPEN WHEN POOL ELEVATION EXCEEDS SPILLWAY CREST

BRUSHY FORK OF STILLWATER CREEK
OHIO

**CLENDENING LAKE
INFLOW-OUTFLOW HYDROGRAPH
FOR SPILLWAY DESIGN FLOOD**

DEPARTMENT OF THE ARMY
HUNTINGTON DISTRICT, CORPS OF ENGINEERS

HUNTINGTON, W.V. REDRAWN FEBRUARY 2005

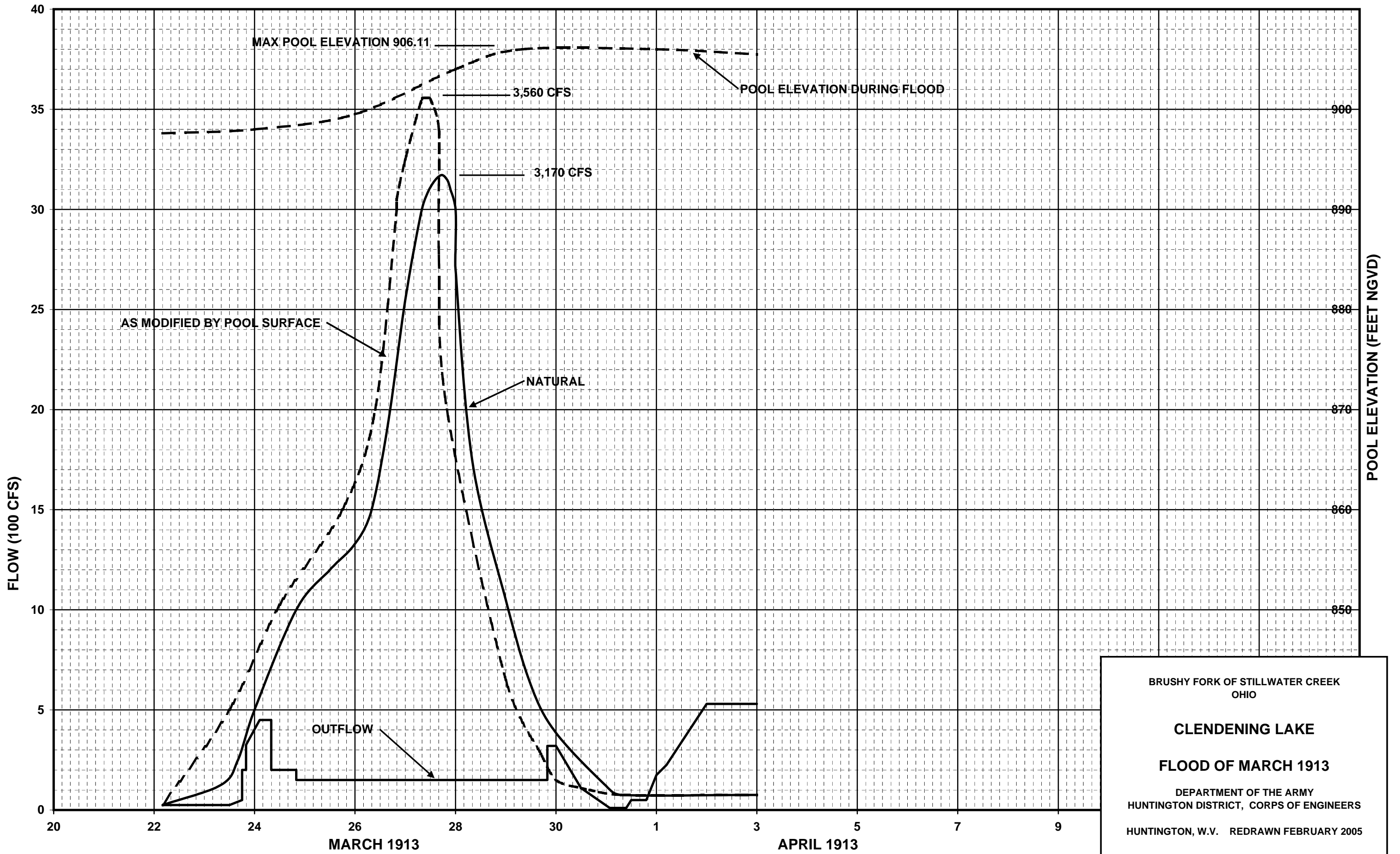

BRUSHY FORK OF STILLWATER CREEK
OHIO

CLENDENING LAKE

FLOOD OF MARCH 1913

DEPARTMENT OF THE ARMY
HUNTINGTON DISTRICT, CORPS OF ENGINEERS

HUNTINGTON, W.V. REDRAWN FEBRUARY 2005

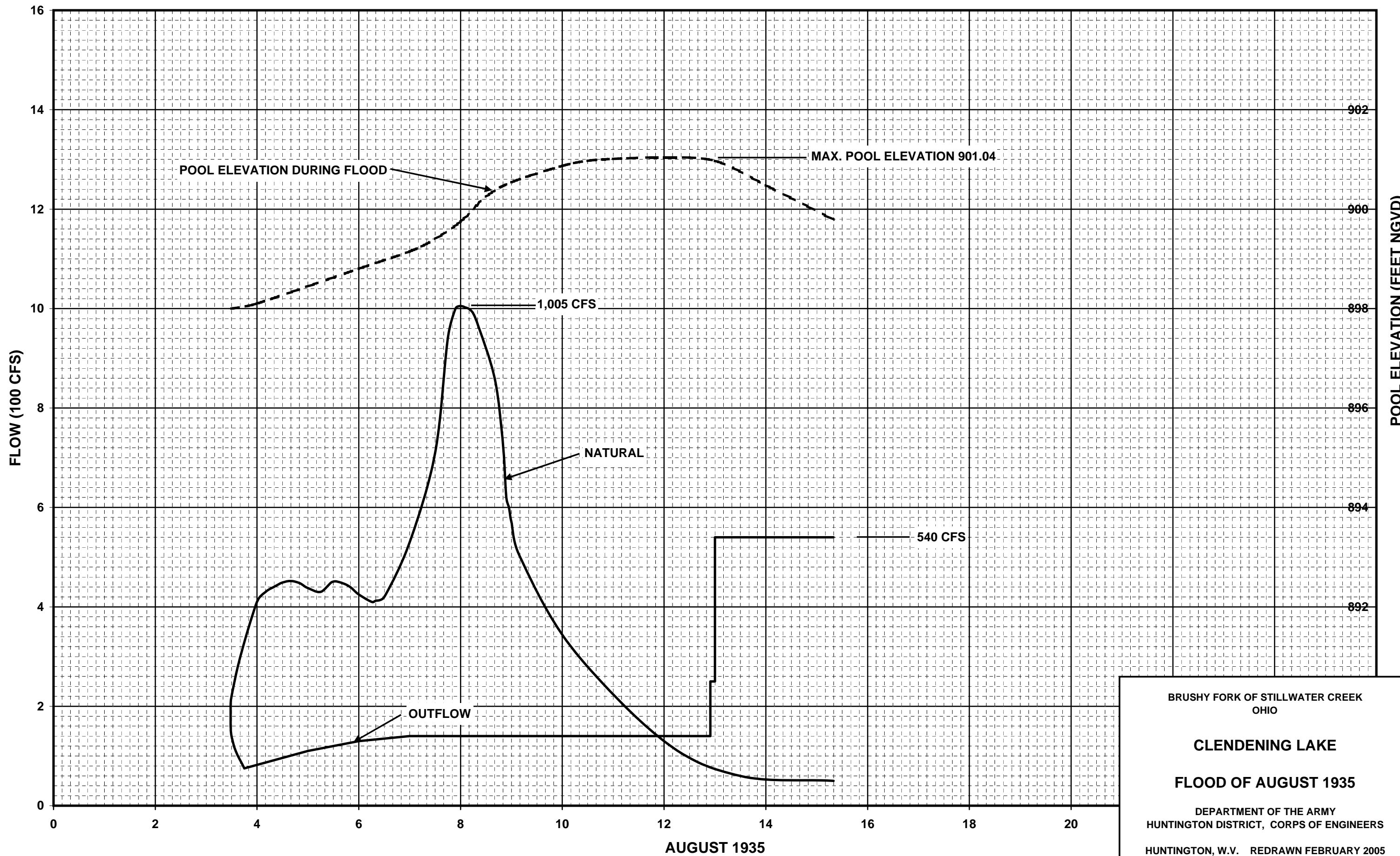

BRUSHY FORK OF STILLWATER CREEK
OHIO

CLENDENING LAKE

FLOOD OF AUGUST 1935

DEPARTMENT OF THE ARMY
HUNTINGTON DISTRICT, CORPS OF ENGINEERS

HUNTINGTON, W.V. REDRAWN FEBRUARY 2005

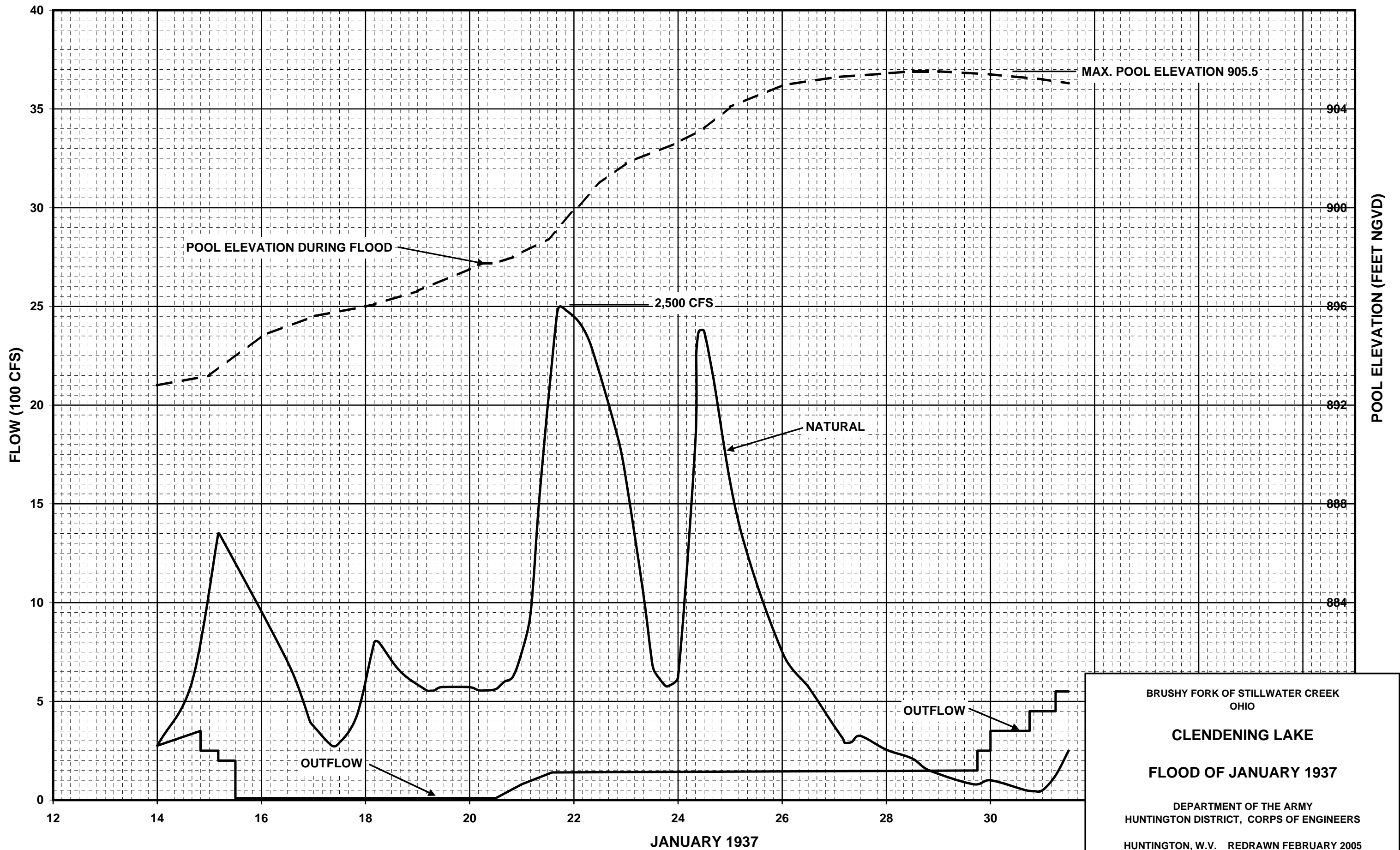

BRUSHY FORK OF STILLWATER CREEK
OHIO

CLENDENING LAKE

FLOOD OF JANUARY 1937

DEPARTMENT OF THE ARMY
HUNTINGTON DISTRICT, CORPS OF ENGINEERS

HUNTINGTON, W.V. REDRAWN FEBRUARY 2005

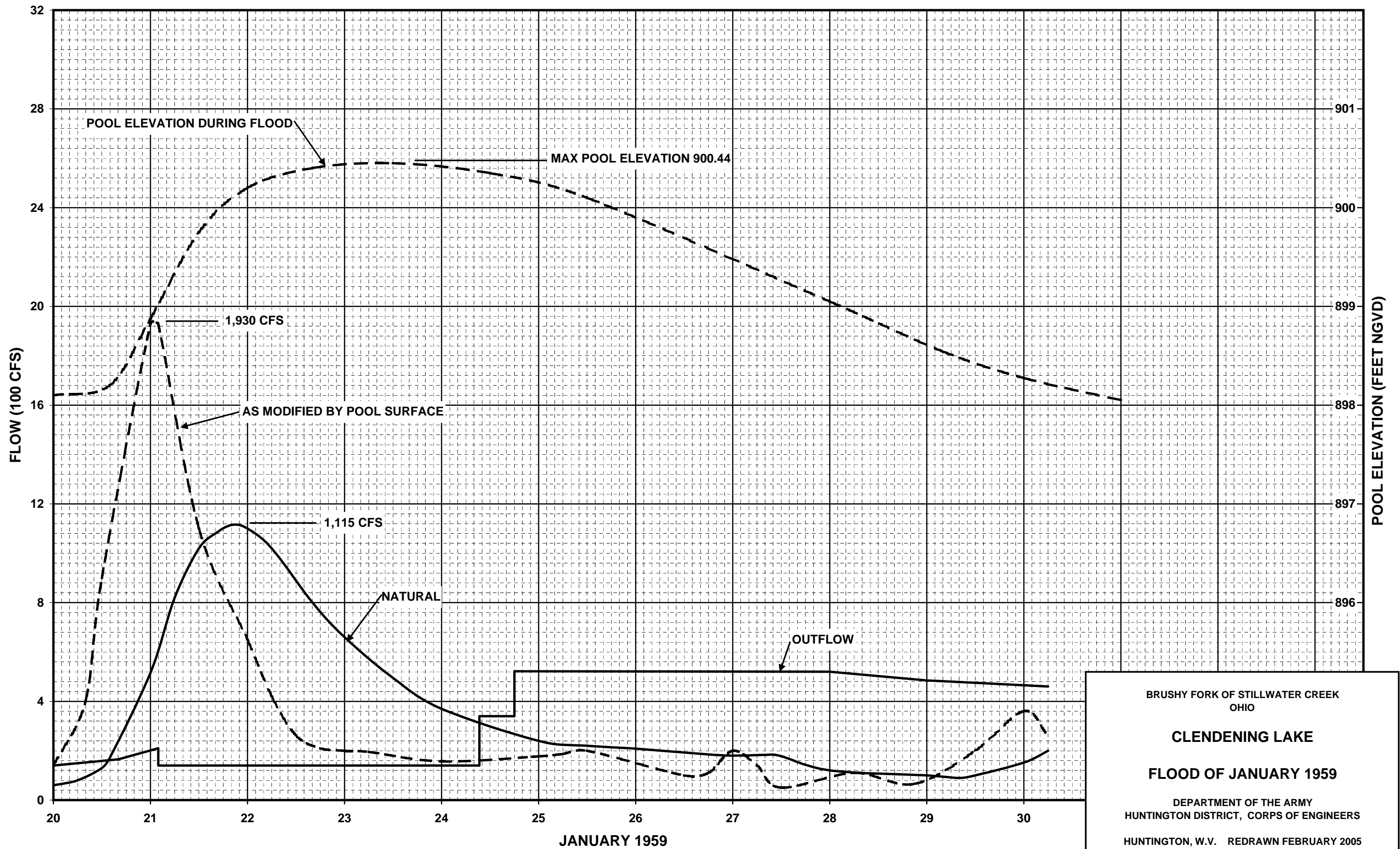

BRUSHY FORK OF STILLWATER CREEK
OHIO

CLENDENING LAKE

FLOOD OF JANUARY 1959

DEPARTMENT OF THE ARMY
HUNTINGTON DISTRICT, CORPS OF ENGINEERS

HUNTINGTON, W.V. REDRAWN FEBRUARY 2005

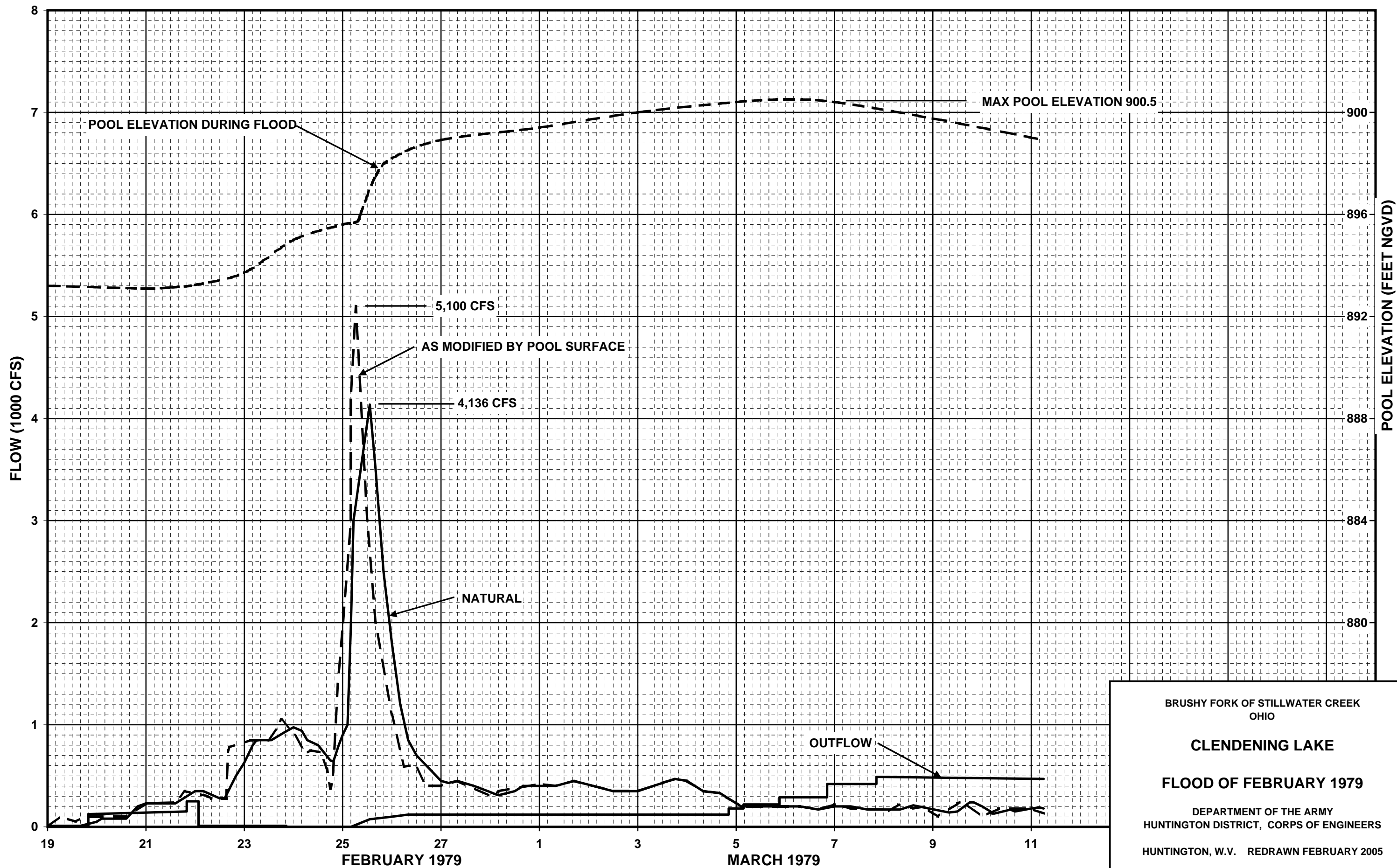

BRUSHY FORK OF STILLWATER CREEK
OHIO

CLENDENING LAKE

FLOOD OF FEBRUARY 1979

DEPARTMENT OF THE ARMY
HUNTINGTON DISTRICT, CORPS OF ENGINEERS

HUNTINGTON, W.V. REDRAWN FEBRUARY 2005

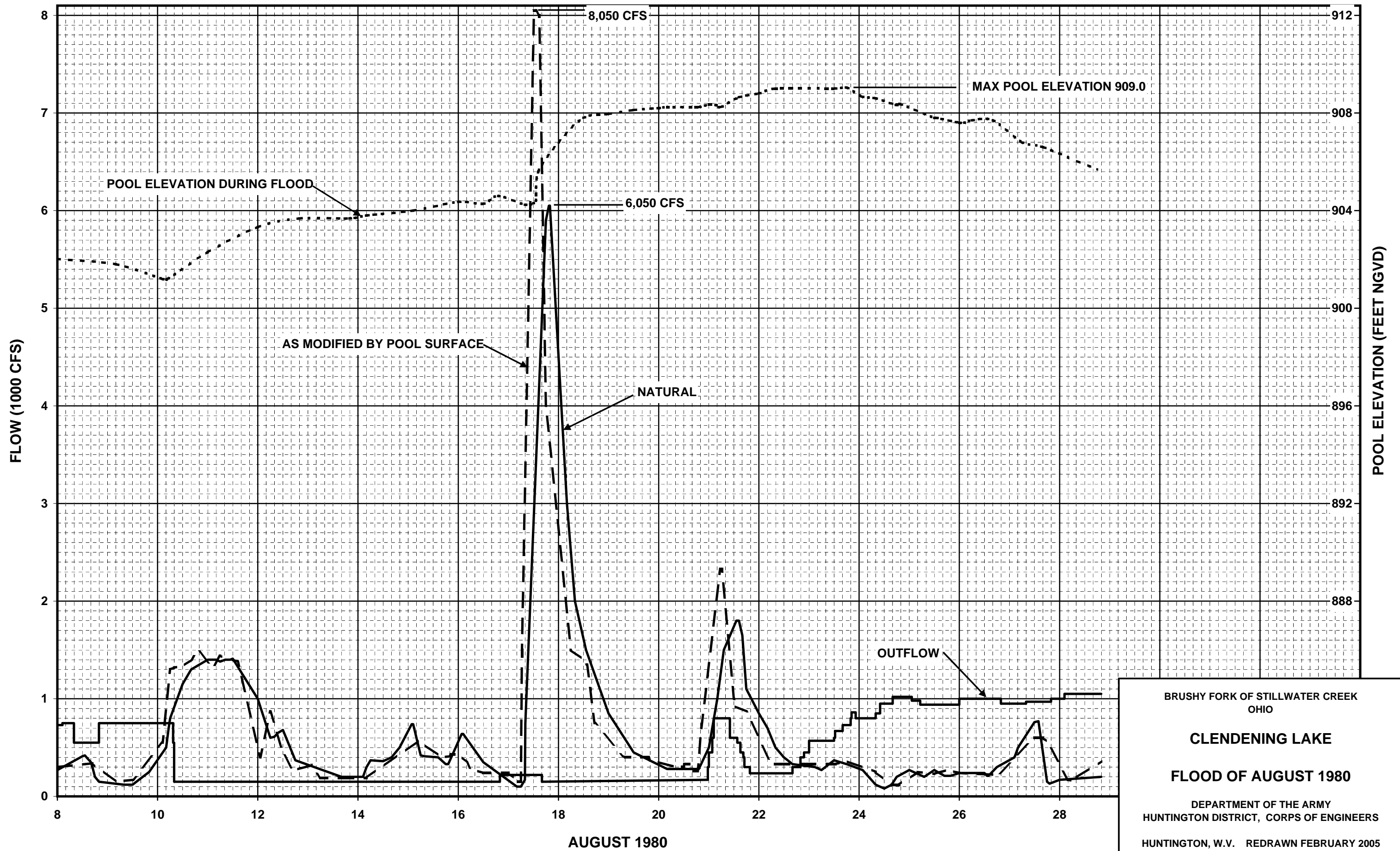

BRUSHY FORK OF STILLWATER CREEK
OHIO

CLENDENING LAKE

FLOOD OF AUGUST 1980

DEPARTMENT OF THE ARMY
HUNTINGTON DISTRICT, CORPS OF ENGINEERS

HUNTINGTON, W.V. REDRAWN FEBRUARY 2005

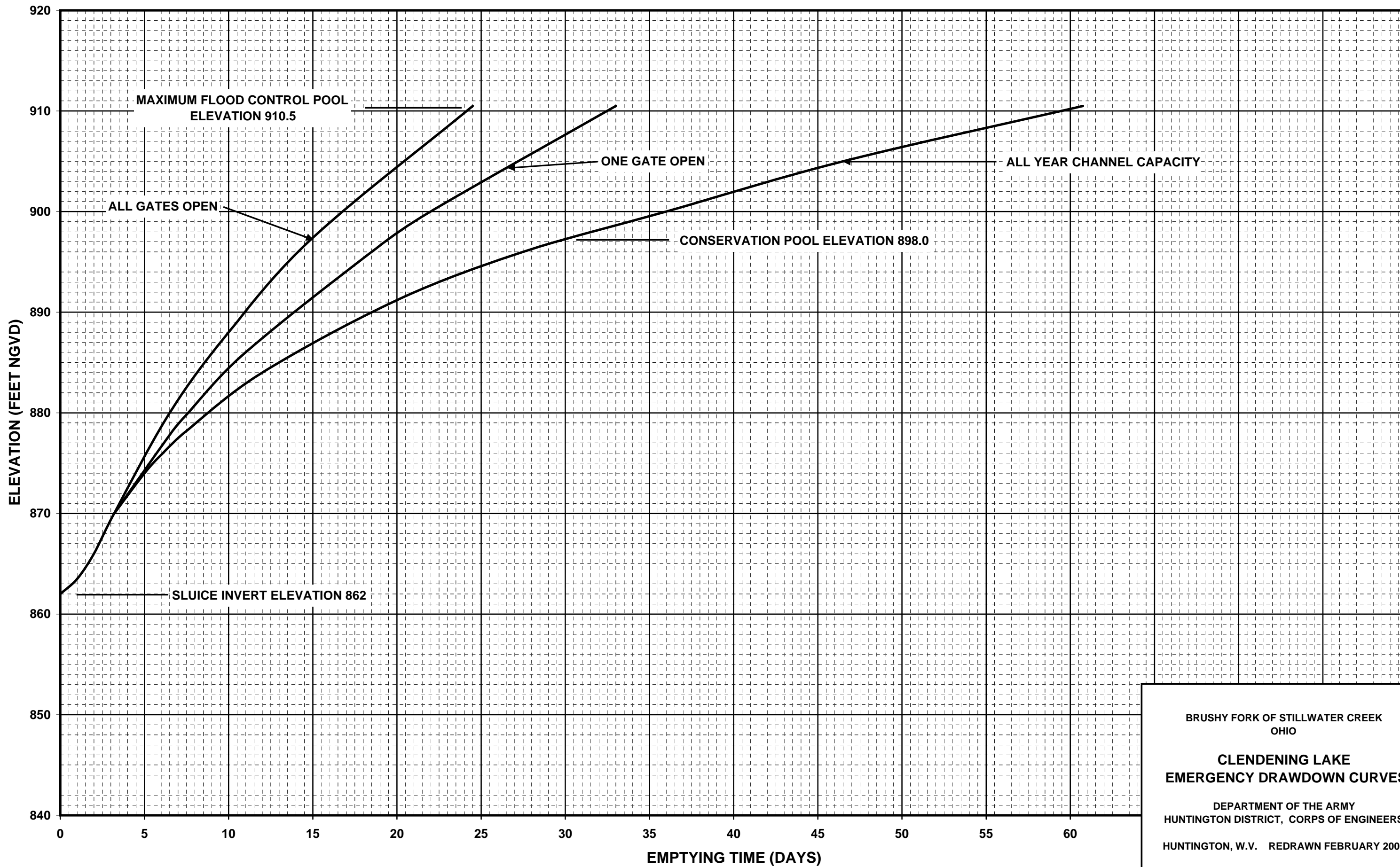

BRUSHY FORK OF STILLWATER CREEK
OHIO

**CLENDENING LAKE
EMERGENCY DRAWDOWN CURVES**

DEPARTMENT OF THE ARMY
HUNTINGTON DISTRICT, CORPS OF ENGINEERS
HUNTINGTON, W.V. REDRAWN FEBRUARY 2005

**Clendening Lake
Water Temperature
Aug 7, 2002**

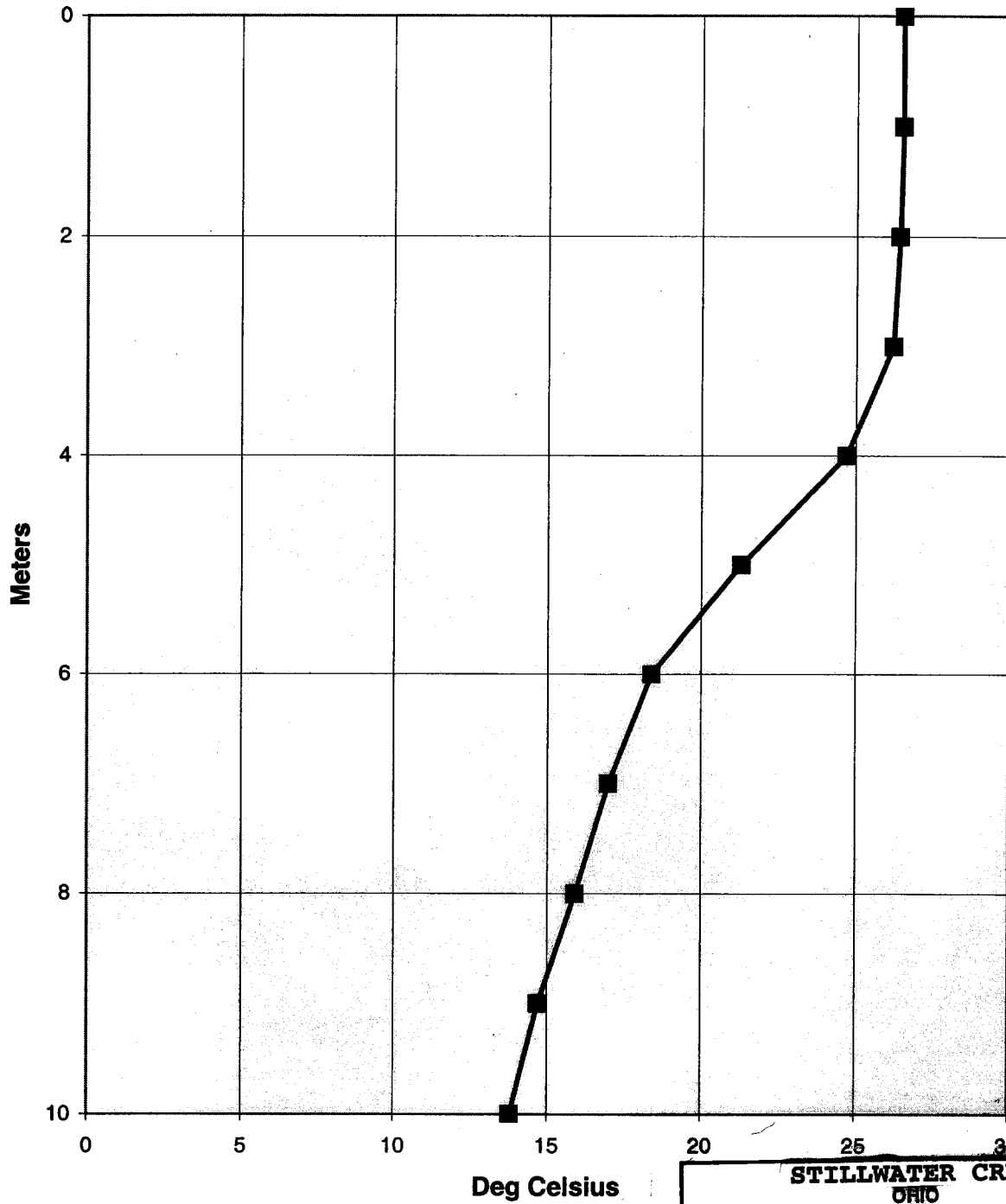

**STILLWATER CREEK
OHIO
CLENDENING LAKE
WATER TEMPERATURE
AUGUST 13, 1996**

DEPARTMENT OF THE ARMY
HUNTINGTON DISTRICT, CORPS OF ENGINEERS
HUNTINGTON, WV REDRAWN MARCH 2003

**Clendening Lake
Dissolved Oxygen
Aug 7, 2002**

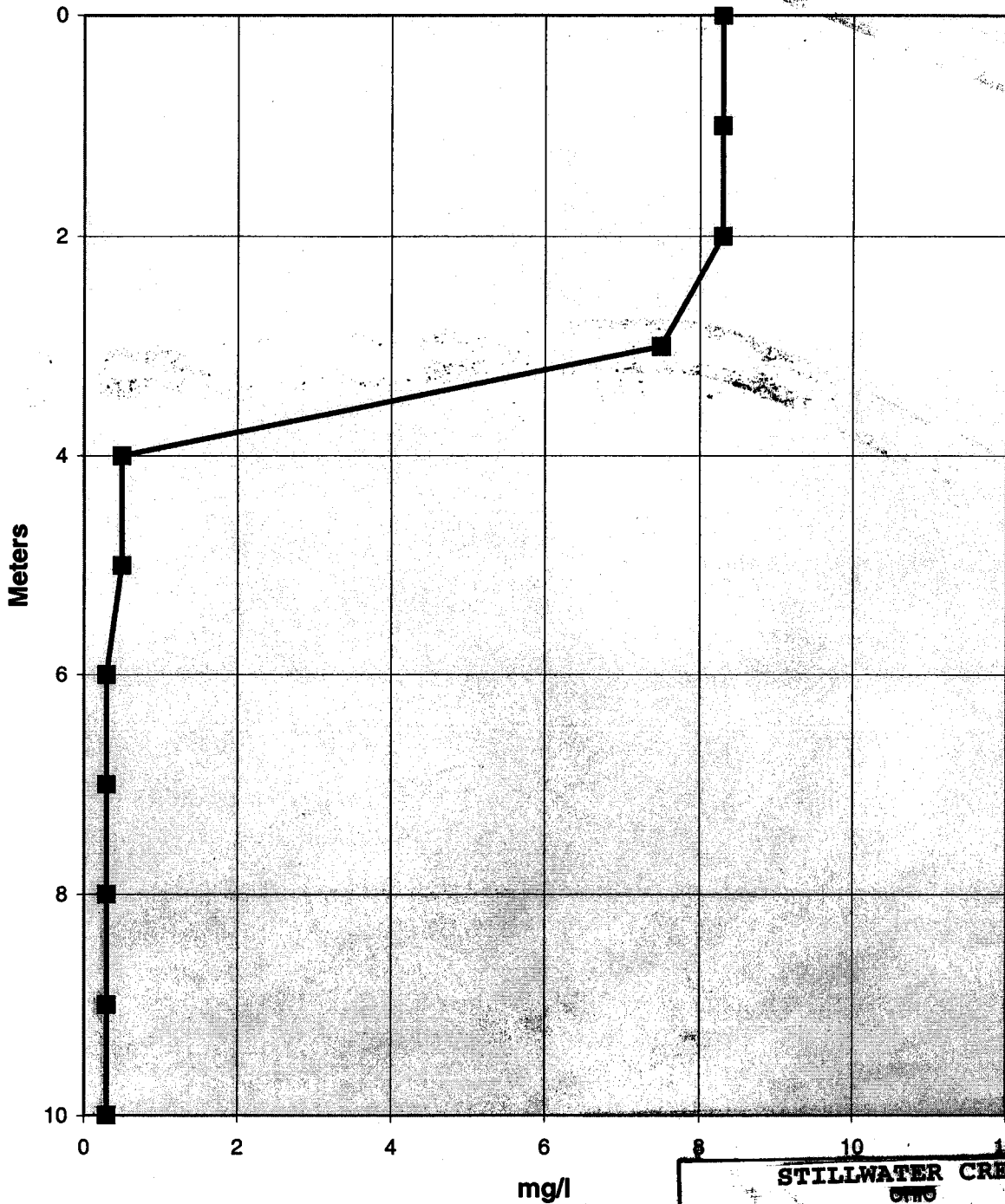

**STILLWATER CREEK
CLENDENING LAKE
DISSOLVED OXYGEN
AUGUST 13, 1996**

DEPARTMENT OF THE ARMY
HUNTINGTON DISTRICT, CORPS OF ENGINEERS
HUNTINGTON, WV REDRAWN MARCH 2003

**Clendening Lake
Total Iron
Aug 7, 2002**

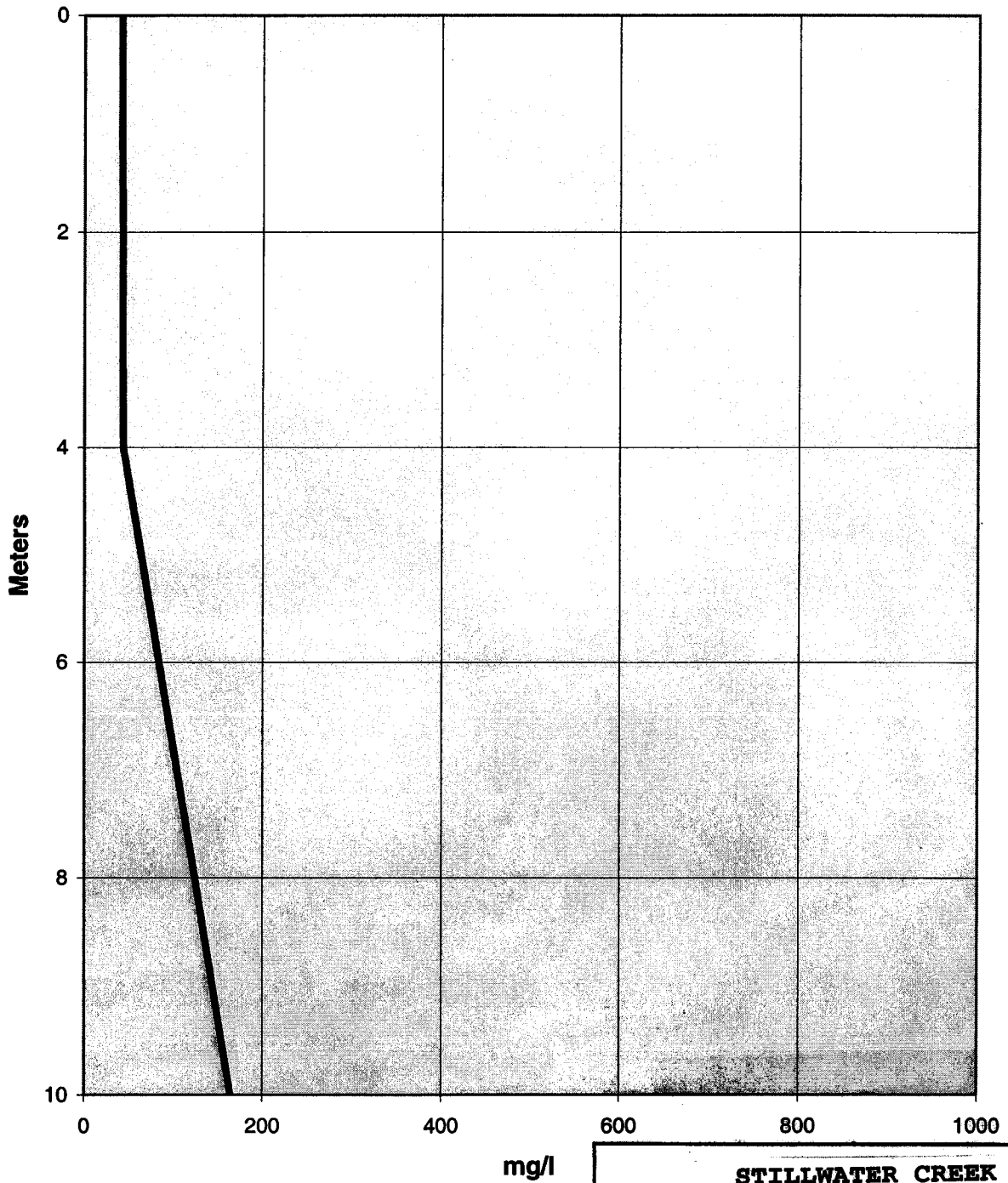

**STILLWATER CREEK
OHIO**
**CLENDENING LAKE
TOTAL IRON**
DEPARTMENT OF THE ARMY
HUNTINGTON DISTRICT, CORPS OF ENGINEERS
HUNTINGTON, WV REDRAWN MARCH 2003

**Clendening Lake
Total Manganese
Aug 7, 2002**

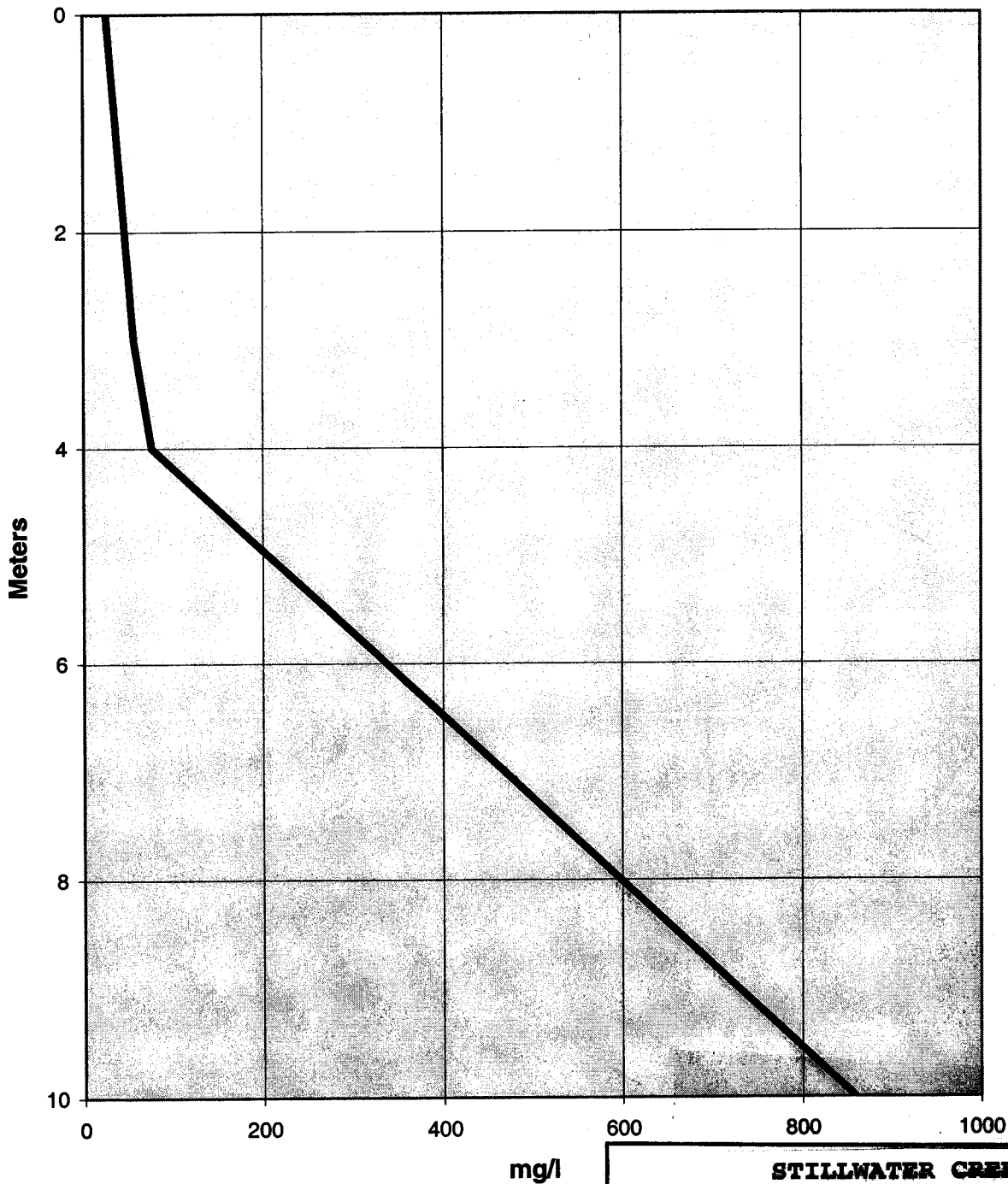

STILLWATER CREEK
OHIO
CLENDENING LAKE
TOTAL MANGANESE
DEPARTMENT OF THE ARMY
HUNTINGTON DISTRICT, CORPS OF ENGINEERS
HUNTINGTON, WV REDRAWN MARCH 2003

OVERALL QUALITY RATING

For Macroinvertebrate Stations

Clendening Lake, Ohio

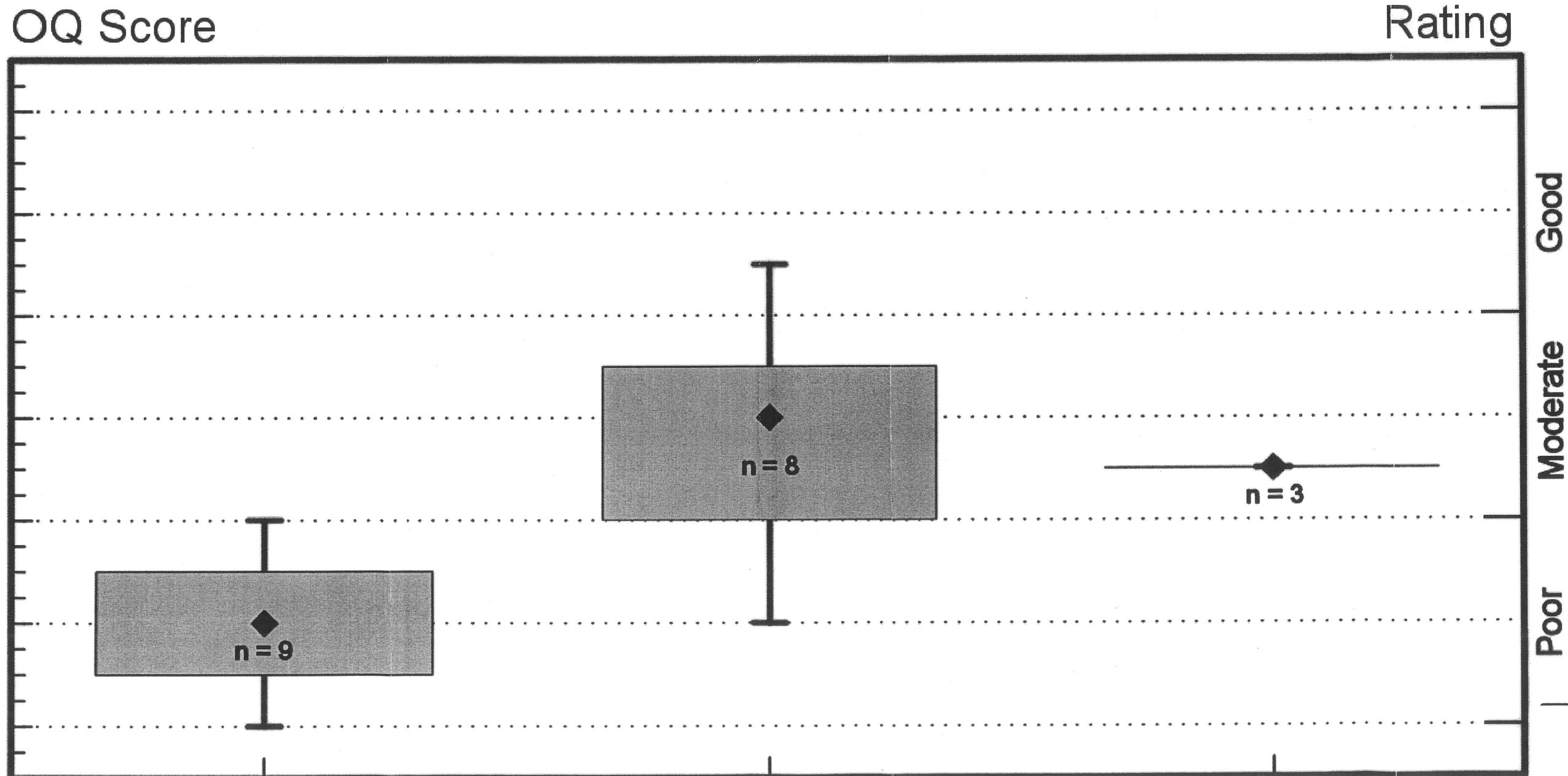

CLB-0004
Outflow - Brushy Fork

CLB-0006
Inflow - Brushy Fork

CLB-0007
Inflow - Elk Run

STILLWATER CREEK
OHIO

CLENDENING LAKE

OVERALL QUALITY RATING

DEPARTMENT OF THE ARMY
HUNTINGTON DISTRICT, CORPS OF ENGINEERS
HUNTINGTON, WV REDRAWN MARCH 2003

**WATER CONTROL
MANAGEMENT MUSKINGUM
RIVER BASIN NORMAL
ORGANIZATION**

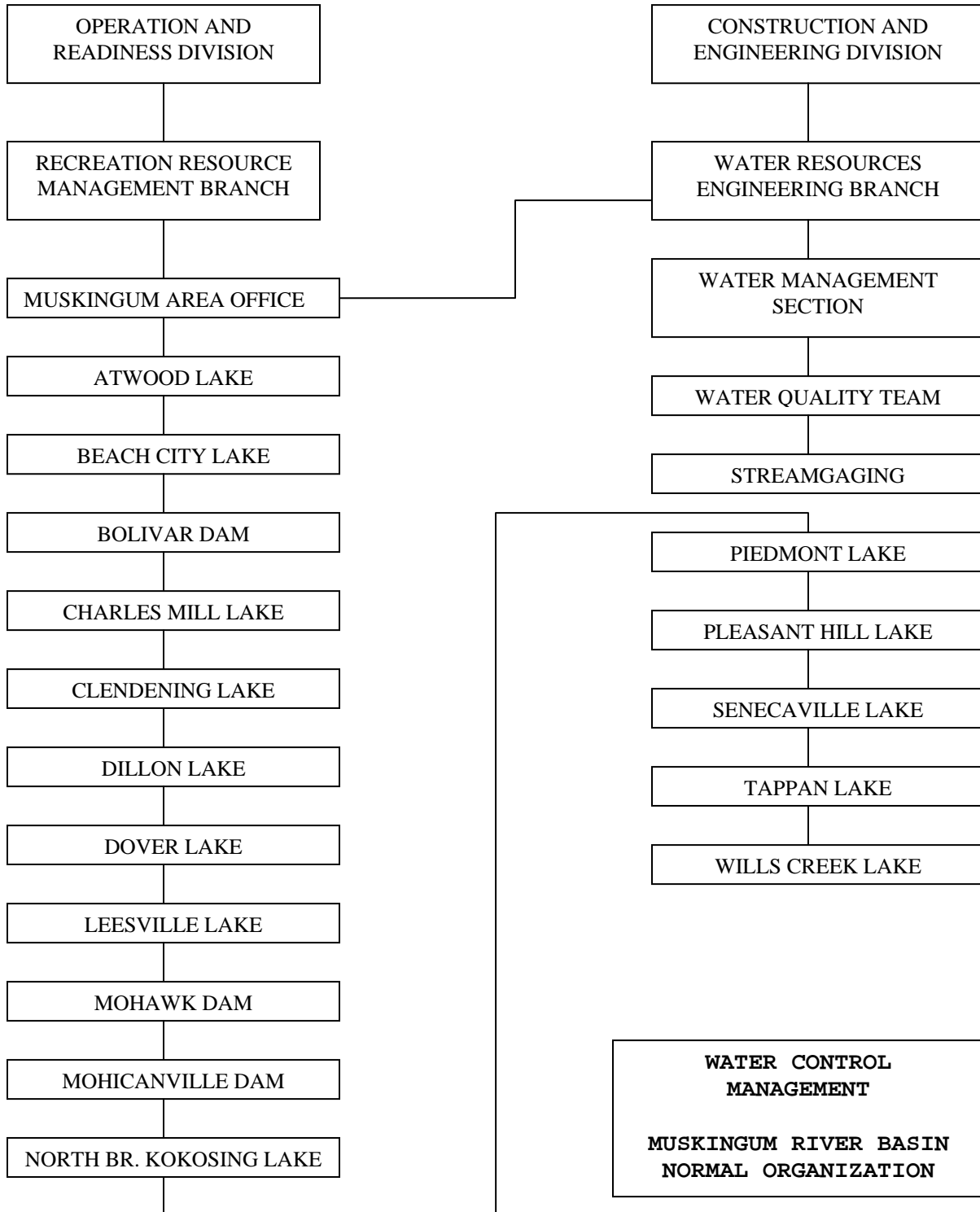

**WATER RESOURCES
ENGINEERING BRANCH
FLOOD EMERGENCY ORGANIZATION**

**CHIEF, WATER RESOURCES
ENGINEERING BRANCH**

CHIEF, WATER MANAGEMENT SECTION

MUSKINGUM AREA OFFICE

ATWOOD LAKE

BEACH CITY LAKE

BOLIVAR DAM

CHARLES MILL LAKE

CLENDENING LAKE

DOVER DAM

LEESVILLE LAKE

**WATER RESOURCES ENGINEERING BRANCH
FLOOD EMERGENCY ORGANIZATION**

**U.S. ARMY CORPS OF ENGINEERS
HUNTINGTON DISTRICT**

NATIONAL WEATHER SERVICE

PRECIPITATION AND STREAMFLOW
DATA
RIVER FORECASTS

U.S. GEOLOGICAL SURVEY

DISCHARGE MEASUREMENTS

**OHIO DEPARTMENT OF
NATURAL RESOURCES**

FISH & WILDLIFE CONSERVATION
BOATING SAFETY
ENFORCEMENT OF HUNTING &
FISHING REGULATIONS & LICENSES

**MUSKINGUM WATERSHED
CONSERVANCY DISTRICT**

MANAGES AND/OR LEASES THE
LAND AND WATER RESOURCES
INCLUDING RECREATION
FACILITIES

NO FORMAL CONTRACT WITH ANY
LAW ENFORCEMENT AGENCY FOR
ROUTINE SURVEILLANCE.
HARRISON COUNTY SHERIFF
WILL RESPOND IN EMERGENCY.

**DISTRICT RELATIONS WITH
OTHER AGENCIES**

CLENDENING LAKE